

G L



BIDIRECTIONAL WAFER KNIFE GATE VALVE

DESCRIPTION

- Bidirectional wafer-design knife gate valve.
- “Monoblock” onepiece cast iron body.
- Stainless steel gate. Two rubber sleeves.
- Provides high flow rates with low pressure drop.
- Various seat materials available.
- Face-to-face dimension in accordance with **CMO Valves** standard.

GENERAL APPLICATIONS

This knife gate valve is suitable for working in the mining industry, in loaded fluid transport lines, such as: water with stones, sludge, etc. and in general it is used for abrasive fluids in the chemical industry and waste water. Designed for the following applications:

Designed for the following applications:

- Thermal power stations
- Energy Sector
- Chemical plants
- Mining
- Sewage treatment

SIZES

DN50 to DN1500

* Others ND on request.

Las presiones indicadas en la tabla, pueden ser utilizadas en cualquiera de los dos sentidos de la válvula.

WORKING PRESSURE (ΔP)

DN50 - DN 150	16 bar
DN200 - DN 600	10 bar
DN700 - DN 900	8 bar
DN1000 - DN 1200	6 bar

* Other pressures, consult.

FLANGE DRILL HOLE

PN10 & ANSI B16.5 (150 LB)

OTHER COMMON FLANGES

- PN 6, PN 16, PN 25, JIS standard
- Australian standard, British standard.

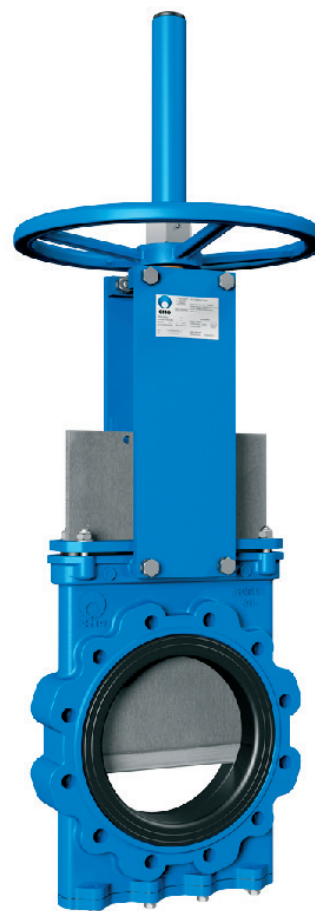

Fig. 1

APPLICATION OF EUROPEAN DIRECTIVES

See document of European Directives applicable to **CMO Valves**.

* For further information on categories and zones please contact the Technical-Commercial Dept. **CMO Valves**.

QUALITY DOSSIER

All valves are tested hydrostatically at **CMO Valves**, and material and test certificates can be provided.

- Body test = working pressure x 1,5
- Seat test = working pressure x 1,1

ADVANTAGE

This knife gate valve's main characteristic is that it provides a full continuous flow. This means that in open position it produces no cavities and there are no turbulences in the fluid. The **GL** valve's body is composed of one single "monoblock" piece.

The stem protection hood is independent from the handwheel securing nut, this means the hood can be disassembled without the need to release the handwheel. This advantage allows regular maintenance operations to be performed, such as lubricating the stem. The stem on the **CMO Valves** valve is made of AISI 304 stainless steel. This is another added advantage, as some manufacturers produce it with 13% chrome and it gets rusty very quickly.

The handwheel is made of nodular cast iron. Some manufacturers produce them in normal cast iron which can lead to breakages in the event of very high operating torque or knocks.

The yoke has a compact design with the bronze actuator nut protected in a sealed and lubricated box. This makes it possible to move the valve with a key, even without the handwheel (in other manufacturers' products this is not possible).

The pneumatic actuator's upper and lower covers are made of nodular cast iron, making them highly shock resistant. This characteristic is essential in pneumatic actuators.

The pneumatic cylinder's o-ring seals are commercial products and can be purchased worldwide. This means it is not necessary to contact **CMO Valves** every time a seal is required.

STANDARD COMPONENTS LIST

COMPONENTS	NODULAR IRON	ST. STEEL
1 BODY	GJS500-7	CF8M
2 GATE	AISI304	AISI316
3 PACKING GLAND	STEEL	AISI316
4 PACKING SEAL.	NATURAL RUBBER	
5 PACKING	GREASED PACK	
6 LOWER COVER	STEEL	AISI316
7 SLEEVE	NATURAL RUBBER	
8 SUPPORT PLATES	STEEL	
9 STEM	AISI303	
10 YOK	GJS500-7	
11 STEM NUT	BRONZE	
12 HANDWHEEL	GJS500-7	
13 STOP NUT	STEEL	
14 HOOD NUT	5.6 ZINC	
15 HOOD	STEEL	
16 PROTEC. CAP	PLASTIC	
17 GREASER (OPTIONAL)	STEEL	

Table. 1

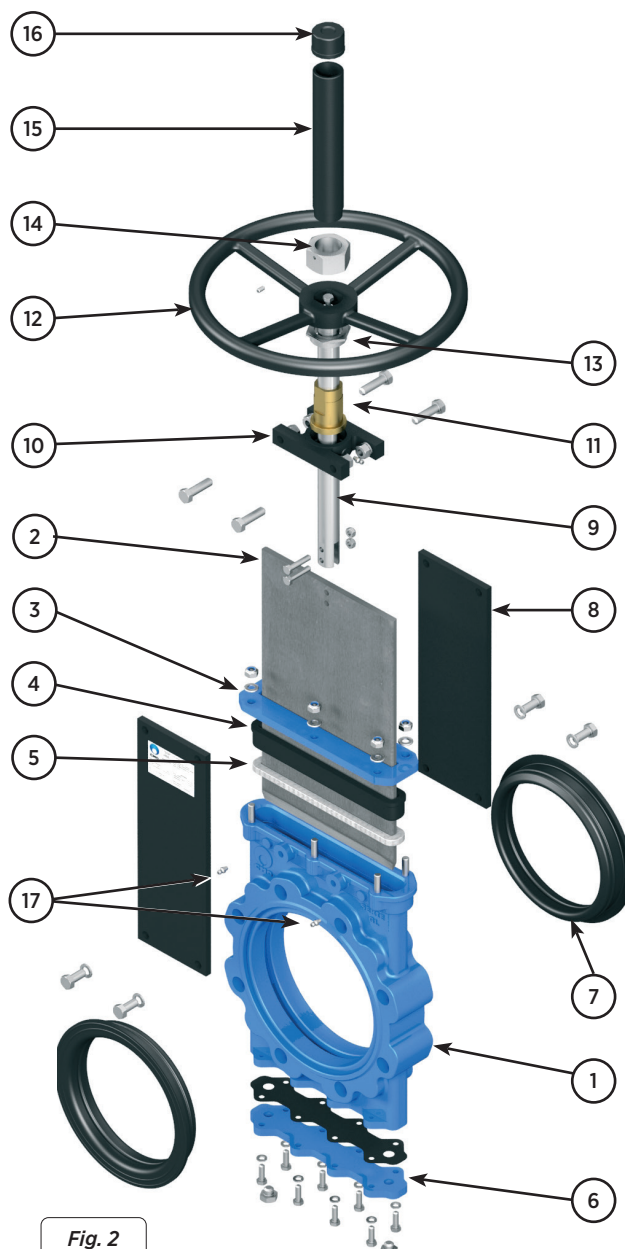

Fig. 2

DESIGN CHARACTERISTICS

1. BODY

One piece reinforced cast iron body. The body provides a full continuous flow. This means that in open position it produces no cavities and, therefore, there are no turbulences in the fluid and the load loss is minimal. For diameters greater than DN600 the body is machine-welded with the necessary reinforcements to resist the maximum working pressure. Full port designed to provide high flow rates with low pressure drop. The body's internal design prevents any build up of solids in the seat area. The standard manufacturing materials are GJS500-7 and CF8M stainless steel. Other materials such as: A216WCB carbon steel and stainless steel alloys (AISI316Ti, Duplex, 254SMO, Uranus B6, Ni-Resist, Ductile Ni-Resist...) are available on request. As standard, iron or carbon steel valves are painted with an anti-corrosive protection of 80 microns of EPOXY (colour RAL 5015). Other types of anti-corrosive protections are available on request.

2. GATE

The standard manufacturing materials are AISI304 stainless steel in valves with GJS500-7 body and AISI316 stainless steel in valves with CF8M body. Other materials or combinations can be supplied on request. The gate is polished on both sides to provide a smooth contact surface with the resilient seat. At the same time, the sharp edges on the gate are rounded to prevent the seal from being cut. There are different degrees of polishing, anti-abrasion treatments and various options to adapt the valves to the customer's requirements.

RESILIENT SEAT MATERIALS

NATURAL RUBBER

This is the standard resilient seat fitted on **CMO Valves GL model** valves. It can be used in multiple applications at temperatures no higher than 90°C with abrasive products and it provides the valve with 100% watertight integrity. Application: fluids in general.

EPDM

Recommended for temperatures no higher than 90°C*, it provides the valve with 100% watertight integrity. Application: water and acids.

NITRILE

It is used in fluids containing fats or oils at temperatures no higher than 90°C*. It provides the valve with 100% watertight integrity.

FKM

Suitable for corrosive applications and continuous high temperatures of up to 190°C and peaks of 210°C. It provides the valve with 100% watertight integrity.

3. SEAT (watertight)

The seat on the **GL** valve is composed of two rubber sleeves, located on either side of the body symmetrically.

The sleeves are made of natural rubber with a metal core which helps to keep their shape and at the same time prevents deformations. Whilst the valve is in open position, the sleeves' elasticity ensures they are joined together permanently, preventing the accumulation of solids between the two parts of the body.

The **GL** valve is designed for abrasive fluids, and therefore, the sleeves protect the entire surface of the body which would be exposed to the abrasive flow. Regarding the sleeves' maintenance, these can be replaced from outside of the valve, making operation easier. It is a seat with two symmetrical parts, below we show a diagram of the seat.

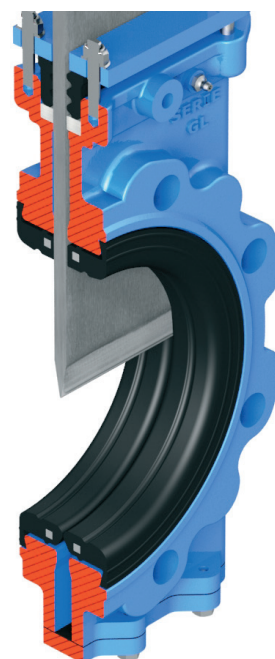

Fig. 3

SEATS/SEALS

MATERIAL	Tª MÁX (°C)	APLICACIONES
Natural rubber	90	General
EPDM (E)	90*	Water, non mineral acids and oils
Nitrile (N)	90*	Hydrocarbons, oils and greases
FKM (V)	200	Hydrocarbons and solvents

Table. 2

Note: More details and other materials on request

* EPDM and Nitrile: it is possible up to Tª Max: 120°C on request

4. PACKING

Standard packing is composed of a specially designed EPDM O-ring which provides watertight integrity between the body and the gate, preventing any type of leakage to the atmosphere. It also has a greased packing strip to help the valve’s operation during the opening and closing functions. They are located in an easily accessible place and can be replaced without dismantling the valve from the pipeline.

5. STEM

The stem on the **CMO Valves** is made of AISI 304 stainless steel. This characteristic provides high resistance and excellent corrosion-resistant properties. The valve design can be rising stem or non-rising stem. When a rising stem is required for the valve a stem hood is supplied to protect the stem from contact with dust and dirt, besides keeping it lubricated.

6. PACKING GLAND

The packing gland allows uniform force and pressure to be applied to the packing to ensure watertight integrity. As standard, valves with steel body include steel packing glands, whilst valves with stainless steel body have stainless steel packing glands.

7. ACTUATORS

All types of actuators can be supplied, with the advantage that the **CMO Valves** design is fully interchangeable. This design allows the customer to change the actuators themselves and no extra assembly accessories are required. A design characteristic of **CMO Valves** is that all actuators are interchangeable.

Manual Drives
Handwheel (*)
Chain handwheel (*)
Lever
Geared motor (*)
Others (square stem)

Availability of Accessories
Mechanical stoppers
Locking devices
Emergency manual drives
Electrovalves
Positioners
Limit switches
Proximity detectors
Straight floor stand (Fig. 4)
Leaning floor stand (Fig. 5)

Automatic Drives
Electric actuator (*)
D/E & S/E pneumatic cylinder
Hydraulic cylinder

(*) Available in rising and non-rising stem versions.

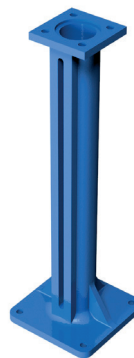

Fig. 4

LEANING FLOOR STANDS.

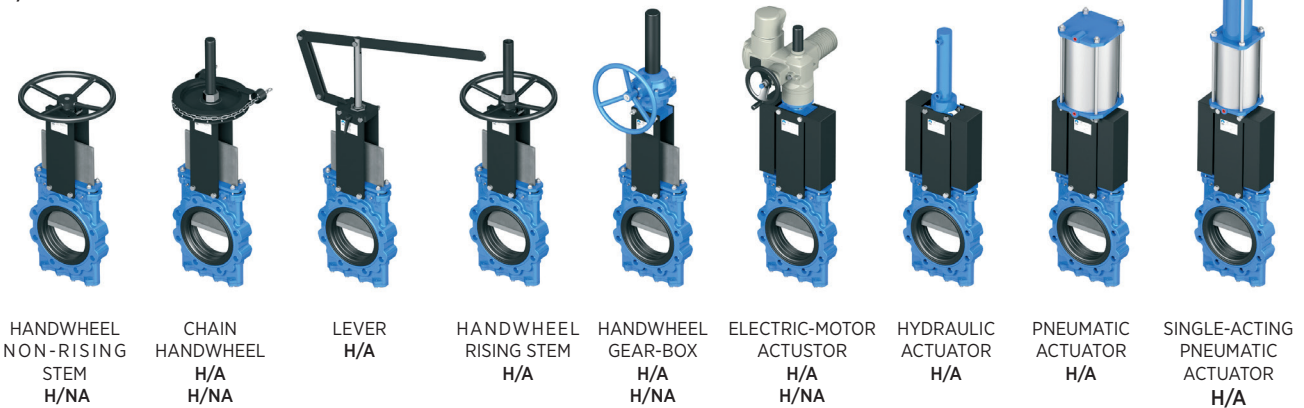

Fig. 5

STRAIGHT FLOOR STANDS.

Stem extensions have also been developed, allowing the drive to be located far away from the valve, to suit all needs. Please ask our engineers beforehand.

H/A = RISING STEM
H/NA = NON-RISING STEM



HANDWHEEL
NON-RISING
STEM
H/NA

CHAIN
HANDWHEEL
H/A
H/NA

LEVER
H/A

HANDWHEEL
RISING STEM
H/A

HANDWHEEL
GEAR-BOX
H/A
H/NA

ELECTRIC-MOTOR
ACTUATOR
H/A
H/NA

HYDRAULIC
ACTUATOR
H/A

PNEUMATIC
ACTUATOR
H/A

SINGLE-ACTING
PNEUMATIC
ACTUATOR
H/A

Fig. 6

OPTIONS AND ACCESSORIES

Different accessories are available to adapt the valve to specific working conditions such as:

MIRROR POLISHED GATE

The mirror polished gate is especially recommended in the food industry and, as standard, in applications in which solids can stick to the gate. It is an alternative to ensure the solids slide off and do not stick to the gate.

PTFE LINED GATE

As with the mirror polished gate, it improves the valve's resistance to products that can stick to the gate.

STELLITED GATE

Stellite is added to the gate's lower edge to protect it from abrasion.

SCRAPER IN THE PACKING

Its function is to clean the gate during the opening movement and prevent possible damage to the packing.

AIR INJECTION IN THE PACKING GLAND

By injecting air in the packing, an air chamber is created which improves the watertight integrity.

HEATING JACKET

Recommended in applications in which the fluid can harden and solidify inside the valve's body. An external jacket keeps the body temperature constant, preventing the fluid from solidifying.

SOLENOID VALVES

For air distribution to pneumatic actuators.

CONNECTION BOXES, WIRING AND PNEUMATIC PIPING

Fully assembled units can be supplied with all the necessary accessories.

MECHANICAL LIMIT SWITCHES, INDUCTIVE SWITCHES AND POSITIONERS

Limit switches or inductive switches are installed to indicate precise valve position, as well as positioners to indicate continuous position.

SOLENOID VALVES

For air distribution to pneumatic actuators.

MECHANICAL STROKE LIMITING STOP (MECHANICAL STOPPERS):

These allow the stroke to be mechanically adjusted, limiting the valve run.

EMERGENCY MANUAL ACTUATOR (HAND WHEEL /GEAR BOX)

Allows manual operation of the valve in the event of power or air failure.

INTERCHANGEABLE ACTUATORS

All actuators are easily interchangeable, except the lever.

DRIVE OR YOKE SUPPORT

Made of EPOXY-coated steel (or stainless steel to order), its robust design gives it great rigidity in order to withstand the most adverse operation conditions.

EPOXY COATING

All cast iron and carbon steel bodies and components on **CMO Valves** are EPOXY coated, giving the valves great resistance to corrosion and an excellent finish.

CMO Valves's standard colour is blue, RAL-5015.

GATE SAFETY PROTECTION

In accordance with European Safety Standards ("EC" marking), **CMO Valves** automated valves are equipped with gate guards, to prevent any objects from being accidentally caught in the gate.

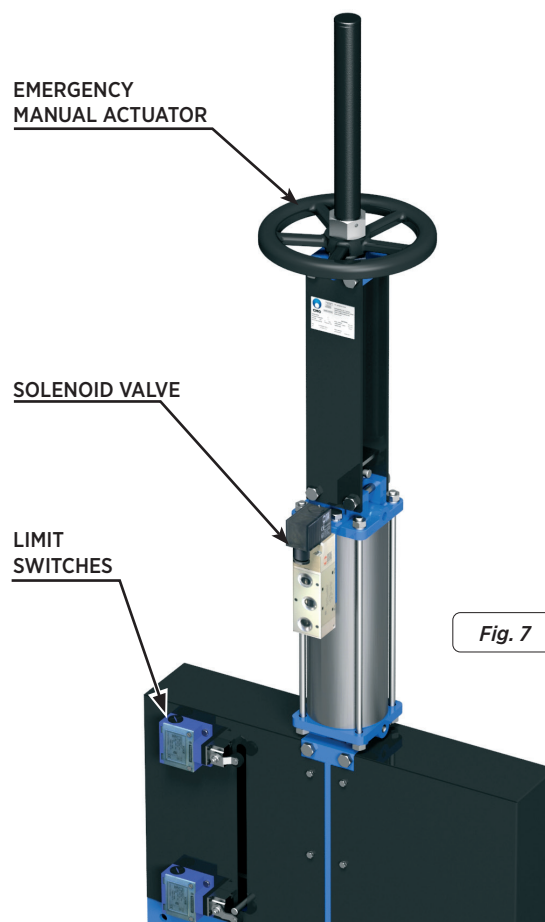

TYPES OF EXTENSIONS

When the valve needs to be operated from a distance, the following different types of actuators can be fitted:

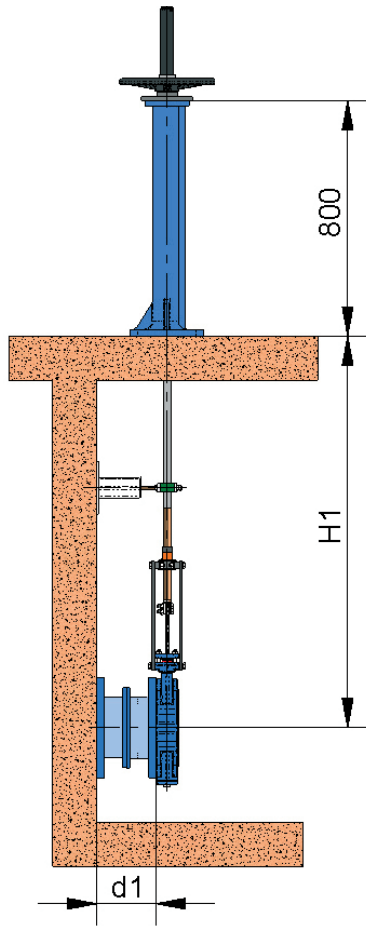

Fig. 8

STANDARD OPERATION STAND.

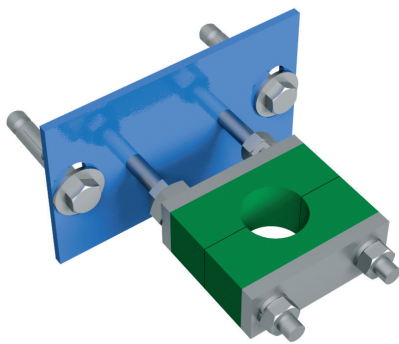

Fig. 9

STEM GUIDE BRACKET

COMPONENT LIST

COMPONENT	STANDARD VERSION
Stem	AISI 304
Rod	AISI 304
Support-Guide	Carbon steel with EPOXY coating
Guide	PA6
Stand	GJS500-7 with EPOXY coating

Table. 3

1- FLOOR STAND

This extension is done by coupling a spindle to the stem. The desired extension is achieved by defining the length of the spindle. A floor stand is normally installed to support the drive.

The definition variables are as follows:

H1 = Distance from valve centre to base of the stand

d1 = Separation from the wall to the end of the connecting flange

CHARACTERISTICS:

- It can be coupled to any type of drive.
- We recommend a stem guide bracket every 1.5 m
- The standard floor stand is 800 mm high.
- Option to use a position indicator to determine the valve's percentage of opening.
- Leaning stand available to order
- Other floor stand measurements available on request.



LEANING STAND.

Fig. 10

2.- PIPE

This consists of raising the drive. The pipe will rotate in the same direction as the wheel when the valve is operated. The valve always remains at the same height.

The definition variables are as follows:

H1 = Distance from valve centre to base of the stand

d1 = Separation from the wall to the end of the connecting flange

CHARACTERISTICS:

- Standard drives: handwheel and top square.
- A pipe guide bracket is recommended every 1.5 m.
- The standard materials are: EPOXY-coated carbon steel and stainless steel.

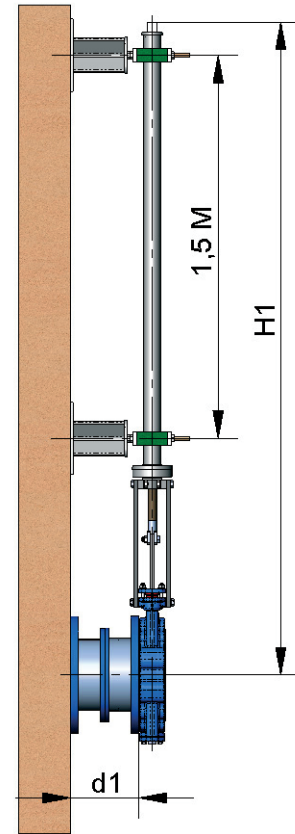

Fig. 11

3.- ELONGATED SUPPORT PLATES

When a short extension is required, it can be achieved by extending the support plates. An intermediate yoke can be fitted to reinforce the support plates structure.

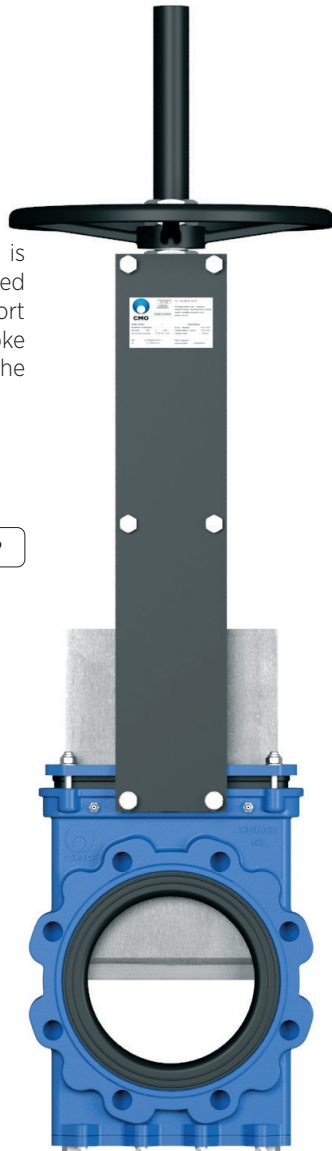

Fig. 12

4.- CARDAN

If the valve and the drive are not in correct alignment, the problem can be resolved by fitting a universal cardan joint. This option is only valid for non-rising stem drives.



Fig. 13

RISING-STEM HANDWHEEL

The definition variables are as follows:

B = Max. width of the valve (without drive).

P = Max. height of the valve (without drive).

OPTIONS:

- Locking devices.
- Extensions: stand, pipe, plates.
- DN above those given in the table

ACTUATOR:

- Handwheel
- Stem
- Nut
- Stem protection bonnet

AVAILABLE:

- Standard NDN50 to DN1000.
- From ND350 (included) the actuator is with gear motor.

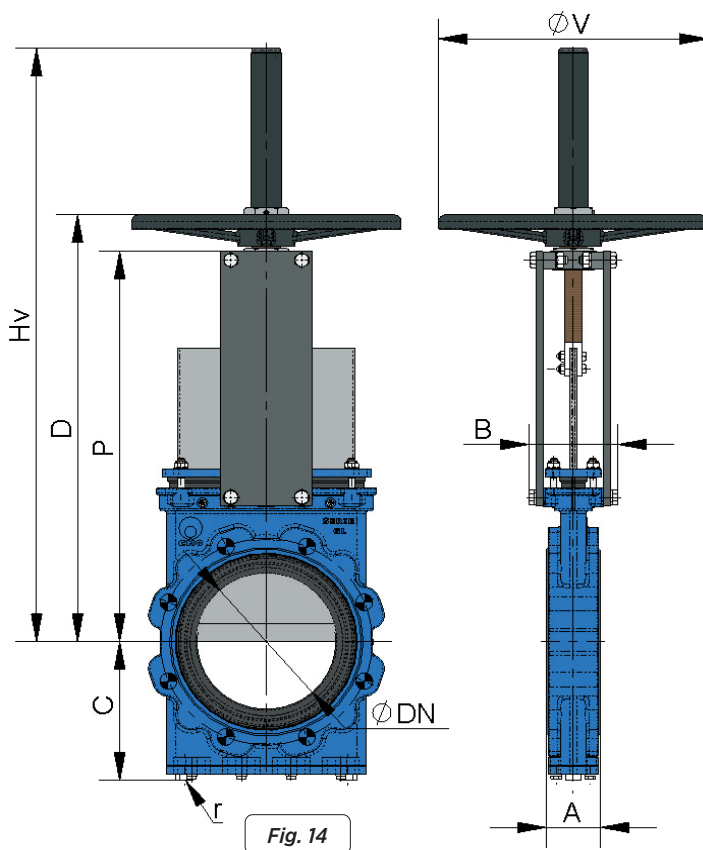

Fig. 14

* Other ND on request.

* Other pressures on request (ΔP)

DN	ΔP (bar)	A	B	C	P	D	HV	ϕV	r (B.S.P.)
50	16	54	109	106	280	319	451	225	1/4"
65	16	54	109	113	306	345	502	225	1/4"
80	16	57	109	122	332	372	553	225	1/4"
100	16	57	109	136	368	407	589	225	1/4"
125	16	64	126	153	421	474	675	325	1/4"
150	16	64	126	168	466	519	759	325	1/4"
200	10	76	126	199	565	618	958	325	3/8"
250	10	76	197	234	626	750	1127	450	1/2"
300	10	83	197	272	739	838	1230	450	1/2"
350	10	83	350	297	842	--	--	--	1/2"
400	10	96	350	330	933	--	--	--	3/4"
450	10	96	350	355	1019	--	--	--	3/4"
500	10	121	380	391	1156	--	--	--	3/4"
600	10	121	400	461	1338	--	--	--	1"
700	8	182	400	534	1425	--	--	--	1"
750	8	188	400	559	1520	--	--	--	1"
800	8	206	400	584	1615	--	--	--	1"
900	8	225	400	649	1823	--	--	--	1"
1000	6	240	440	699	1992	--	--	--	1"

Table. 4

NON-RISING STEM HANDWHEEL

Suitable when no size limitations exist.

The definition variables are as follows:

B = Max. width of the valve (without drive).

P = Max. height of the valve (without drive).

OPTIONS:

- Square nut
- Locking devices
- Extensions: elongated plates...
- ND higher than those give in the table

ACTUATOR:

- Handwheel
- Stem
- Nut.
- Guide bearings on the Yoke

AVAILABLE:

- Standard NDN50 to DN1000.
- From ND350 (included) the actuator is with gear motor.

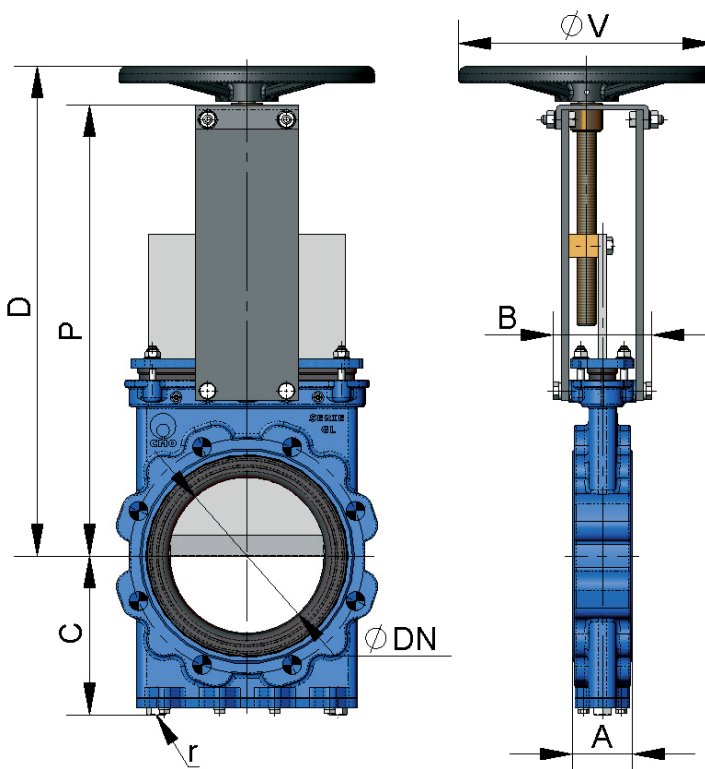

Fig. 15

* Other ND on request.

* Other pressures on request (ΔP)

DN	ΔP (bar)	A	B	C	P	D	ϕV	r (B.S.P.)
50	16	54	109	106	280	319	225	1/4"
65	16	54	109	113	306	345	225	1/4"
80	16	57	109	122	332	372	225	1/4"
100	16	57	109	136	368	407	225	1/4"
125	16	64	126	153	421	474	325	1/4"
150	16	64	126	168	466	519	325	1/4"
200	10	76	126	199	565	618	325	3/8"
250	10	76	197	234	626	750	450	1/2"
300	10	83	197	272	739	838	450	1/2"
350	10	83	350	297	842	942	--	1/2"
400	10	96	350	330	933	1033	--	3/4"
450	10	96	350	355	1019	1119	--	3/4"
500	10	121	380	391	1156	1256	--	3/4"
600	10	121	400	461	1338	1438	--	1"
700	8	182	400	534	1425	1525	--	1"
750	8	188	400	559	1520	1620	--	1"
800	8	206	400	584	1615	1715	--	1"
900	8	225	400	649	1823	1923	--	1"
1000	6	240	440	699	1992	--	--	1"

Table. 5

CHAIN HANDWHEEL

Widely used in raised installations with difficult access, the handwheel is fitted in vertical position

The definition variables are as follows:

B = Max. width of the valve (without drive).

P = Max. height of the valve (without drive).

OPTIONS:

- Locking devices
- Extensions: stand, pipe, plates...
- Non-rising stem.
- DN higher than those give in the table.

ACTUATOR:

- Handwheel
- Stem
- Nut
- Hood

AVAILABLE:

- Standard NDN50 to DN1000.
- From ND350 (included) the actuator is with geared motor.

* Other ND on request.

* Other pressures on request (ΔP)

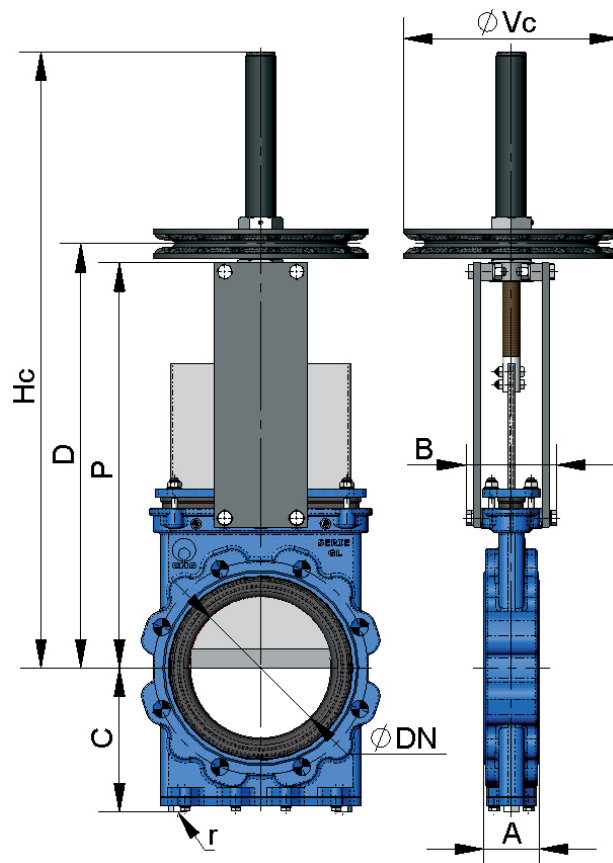

Fig. 16

DN	ΔP (bar)	A	B	C	P	D	Hc	ϕVc	r (B.S.P.)
50	16	54	109	106	280	319	449	225	1/4"
65	16	54	109	113	306	345	500	225	1/4"
80	16	57	109	122	332	372	551	225	1/4"
100	16	57	109	136	368	407	587	225	1/4"
125	16	64	126	153	421	474	713	300	1/4"
150	16	64	126	168	466	519	757	300	1/4"
200	10	76	126	199	565	618	957	300	3/8"
250	10	76	197	234	626	749	1125	402	1/2"
300	10	83	197	272	739	837	1213	402	1/2"
350	10	83	350	297	842	942	1384	402*	1/2"
400	10	96	350	330	933	1033	1627	402*	3/4"
450	10	96	350	355	1019	1119	1719	402*	3/4"
500	10	121	380	391	1156	1256	1890	402*	3/4"
600	10	121	400	461	1338	1438	2171	402*	1"
700	8	182	400	534	1425	1525	2440	402*	1"
750	8	188	400	559	1520	1620	2555	402*	1"
800	8	206	400	584	1615	1715	2665	402*	1"
900	8	225	400	649	1823	1923	2823	402*	1"
1000	6	240	440	699	1992	2092	3192	402*	1"

Table. 6

LEVER

It is a fast actuator.

The definition variables are as follows:

B = Max. width of the valve (without drive).

P = Max. height of the valve (without drive).

ACTUATOR:

- Level
- Rod
- Guide Bearing
- External limiting switches to maintain the position

AVAILABLE:

- DN50 to DN200
- Drive designed to maneuver to 2 bar of differential pressure (ΔP)

* Other ND on request.

* Other pressures on request (ΔP)

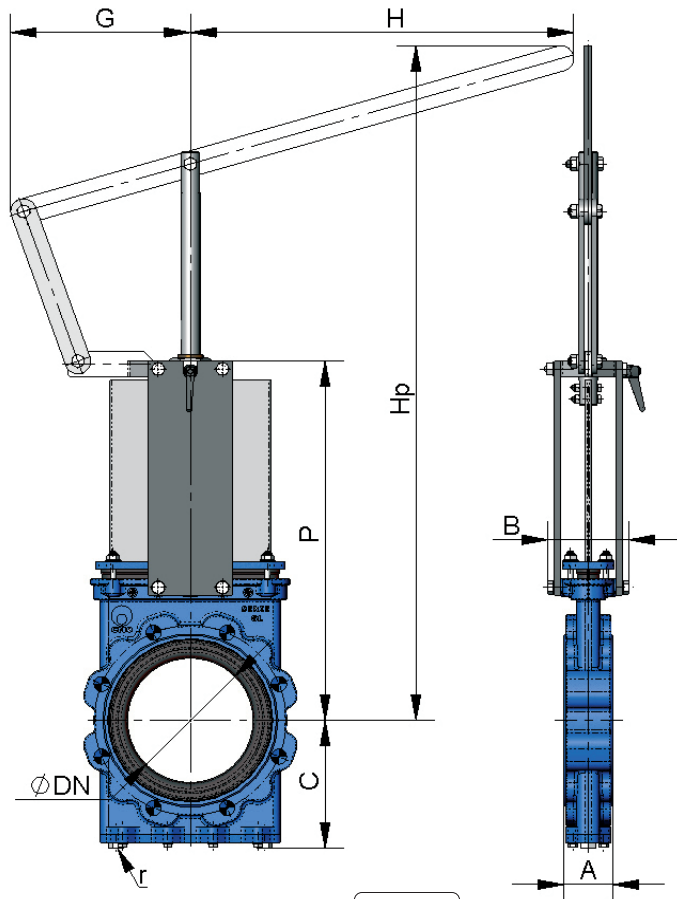

Fig. 17

DN	ΔP (bar)	A	B	C	P	Hp	G	H	r (B.S.P.)
50	16	54	109	106	280	543	155	325	1/4"
65	16	54	109	113	306	564	155	325	1/4"
80	16	57	109	122	332	587	155	325	1/4"
100	16	57	109	136	368	639	155	325	1/4"
125	16	64	126	153	421	942	155	425	1/4"
150	16	64	126	168	466	1002	155	425	1/4"
200	10	76	126	199	565	1068	290	620	3/8"

Table. 7

GEAR BOX

It is recommendable for DN greater than 350

The definition variables are as follows:

B = Max. width of the valve (without actuator).

P = Max. height of the valve (without actuator).

OPTIONS:

- Chainwheel.
- Locking devices.
- Extensions: stand, pipe, plates...
- DN greater than those indicated in the table

ACTUATOR:

- Stem
- Yoke
- Handwheel
- Cone-shaped gear box
- Standard ratio = 4 to 1

AVAILABLE:

- DN50 to DN200

* Other ND on request.

* Other pressures on request (ΔP)

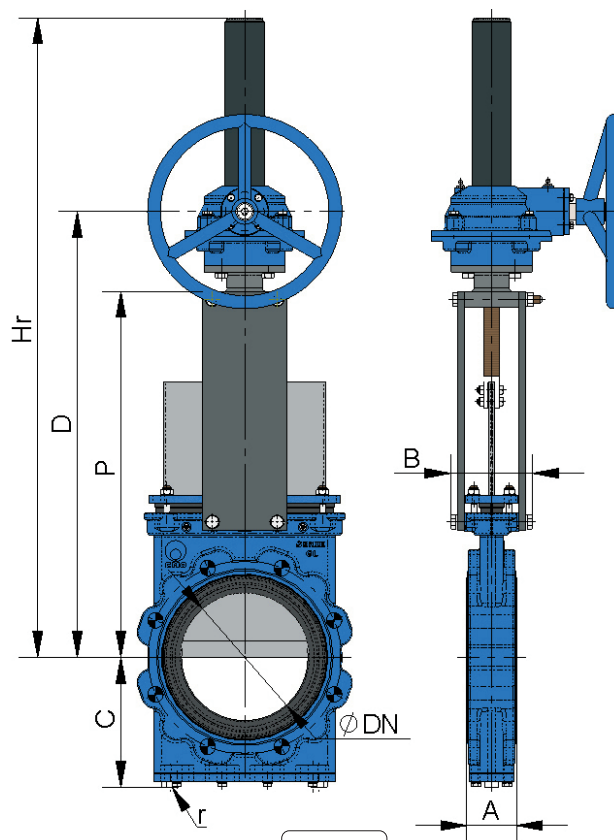

Fig. 18

DN	ΔP (bar)	A	B	C	P	D	Hr	r (B.S.P.)
50	16	54	109	106	280	402	581	1/4"
65	16	54	109	113	306	446	621	1/4"
80	16	57	109	122	332	454	633	1/4"
100	16	57	109	136	368	490	669	1/4"
125	16	64	126	153	421	565	800	1/4"
150	16	64	126	168	466	589	848	1/4"
200	10	76	126	199	565	689	948	3/8"
250	10	76	197	234	626	735	1119	1/2"
300	10	83	197	272	739	833	1217	1/2"
350	10	83	350	297	842	935	1384	1/2"
400	10	96	350	330	933	1028	1627	3/4"
450	10	96	350	355	1019	1120	1719	3/4"
500	10	121	380	391	1156	1275	1889	3/4"
600	10	121	400	461	1338	1457	2171	1"
700	8	182	400	534	1530	1764	2440	1"
750	8	188	400	559	1637	1860	2555	1"
800	8	206	400	584	1733	1950	2807	1"
900	8	225	400	649	1954	2090	3148	1"
1000	6	240	440	699	2160	2233	3579	1"
1100	6	240	440	730	2310	2446	3779	1 1/2"
1200	6	254	480	775	2551	2522	3807	1 1/2"

Table. 8

DOUBLE-ACTING PNEUMATIC CYLINDER

The definition variables are as follows:

B = Max. width of the valve (without actuator).

P = Max. height of the valve (without actuator).

The air supply pressure to the cylinder is a minimum of 6 bar and a maximum of 10 bar, the air must be dry and lubricated.

For ND50 to ND200 valves, the cylinder's jacket and covers are made of aluminium, the rod of AISI304, the piston of rubber-coated steel and the O-ring seals are made of nitrile.

For pneumatic cylinders larger than Ø200 the covers are made of nodular cast iron or carbon steel.

On request, we can also supply the actuator made entirely of stainless steel, especially for installation in corrosive atmospheres.

AVAILABLE:

- DN50 to DN700

* Other ND on request.

* Other pressures on request (ΔP)

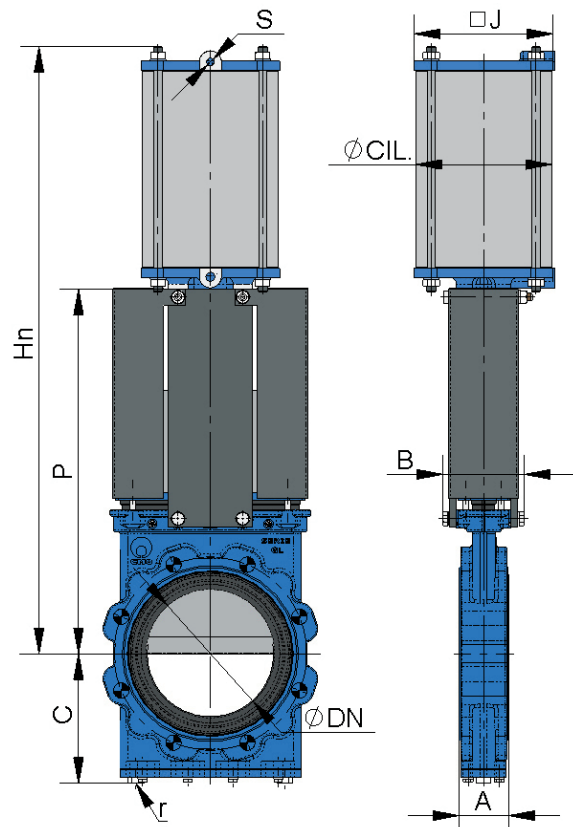

Fig. 19

DN	ΔP (bar)	A	B	C	P	Hn	J	\varnothing CIL	\varnothing VAST	S (B.S.P.)	r (B.S.P.)
50	16	54	109	106	280	475	96	80	20	1/4"	1/4"
65	16	54	109	113	306	515	96	80	20	1/4"	1/4"
80	16	57	109	122	332	555	115	100	20	1/4"	1/4"
100	16	57	109	136	368	620	138	125	25	1/4"	1/4"
125	16	64	126	153	421	700	175	160	30	1/4"	1/4"
150	16	64	126	168	466	775	175	160	30	1/4"	1/4"
200	10	76	126	199	565	940	218	200	30	3/8"	3/8"
250	10	76	197	234	626	1140	270	250	40	3/8"	1/2"
300	10	83	197	272	739	1300	382	300	45	1/2"	1/2"
350	10	83	350	297	842	1485	444	350*	45	1/2"	1/2"
400	10	96	350	330	933	1655	508	400*	50	1/2"	3/4"
450	10	96	350	355	1019	1805	552	450*	50	3/4"	3/4"
500	10	121	380	391	1156	2000	612	500*	50	3/4"	3/4"
600	10	121	400	461	1338	2285	772	585*	60	1"	1"
700	8	182	400	534	1530	2495	772	635*	60	1"	1"

(*) -> For lower working pressures consult \varnothing cylinder.

Table. 9

SINGLE-ACTING PNEUMATIC CYLINDER

The definition variables are as follows:

B = Max. width of the valve (without actuator).

P = Max. height of the valve (without actuator).

The air supply pressure to the cylinder is a minimum of 6 bar and a maximum of 10 bar, the air must be dry and lubricated.

Available for opening or closing in case of air supply failure (spring opening or closing).

The jacket is made of aluminium, the covers of nodular cast iron or carbon steel, the rod of AISI304, the piston of rubber-coated steel, the O-ring seals of nitrile and the spring is made of steel.

The **actuator** design is **spring** activated for valves with diameters **up to ND200**. For larger diameters the actuator contains a double-acting cylinder and an air tank which stores the volume of air necessary to perform the last movement in the event of a air supply failure.

AVAILABLE:

- DN50 to DN200

* Other ND on request.

* Other pressures on request (ΔP)

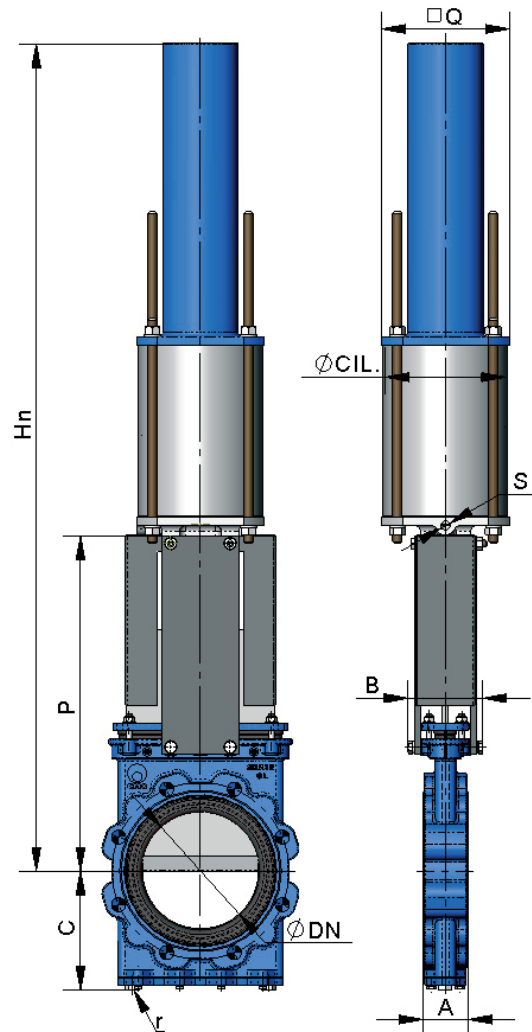

Fig. 20

DN	ΔP (bar)	A	B	C	P	Hn	J	\varnothing CIL	\varnothing VAST	S (B.S.P.)	r (B.S.P.)
50	16	54	109	106	280	752	138	125	25	1/4"	1/4"
65	16	54	109	113	306	794	138	125	25	1/4"	1/4"
80	16	57	109	122	332	836	138	125	25	1/4"	1/4"
100	16	57	109	136	368	906	175	160	30	1/4"	1/4"
125	16	64	126	153	421	986	218	200	30	3/8"	1/4"
150	16	64	126	168	466	1056	218	200	30	3/8"	1/4"
200	10	76	126	199	565	1439	270	250	40	3/8"	3/8"

Table. 10

ELECTRIC ACTUATOR

This actuator is automatic and includes the following parts:

- Electric motor.
- Stem
- Yoke

OPCIONES:

- Different types and brands.
- ISO 5210 / DIN 3338 flanges

AVAILABLE:

- DN 50 to DN 1500
- From ND350 (inclusive) the motor is assisted with a gear box.

* Other ND on request.

* Other pressures on request (ΔP)

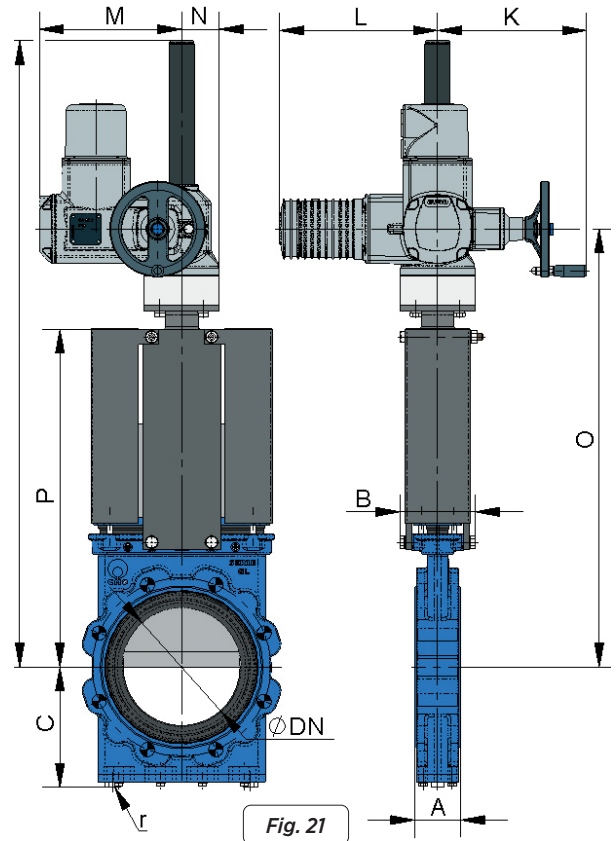

DN	ΔP (bar)	A	B	C	P	K	L	M	N	O	He	r (B.S.P.)
50	16	54	109	106	280	249	265	238	62	436	631	1/4"
65	16	54	109	113	306	249	265	238	62	462	657	1/4"
80	16	57	109	122	332	249	265	238	62	488	683	1/4"
100	16	57	109	136	368	249	265	238	62	524	719	1/4"
125	16	64	126	153	421	249	265	238	62	574	769	1/4"
150	16	64	126	168	466	249	265	238	62	624	819	1/4"
200	10	76	126	199	565	249	265	238	62	723	1033	3/8"
250	10	76	197	234	626	254	283	248	65	781	1121	1/2"
300	10	83	197	272	739	254	283	248	65	879	1219	1/2"
350	10	83	350	297	842	249	265	407	82	975	1384	1/2"
400	10	96	350	330	933	254	283	424	82	1078	1627	3/4"
450	10	96	350	355	1019	254	283	424	82	1170	1719	3/4"
500	10	121	380	391	1156	336	389	479	103	1338	1889	3/4"
600	10	121	400	461	1338	336	389	479	103	1520	2171	1"
700	8	182	400	534	1530	336	389	479	103	1831	2440	1"
750	8	188	400	559	1637	336	389	479	103	1927	2555	1"
800	8	206	400	584	1733	339	389	528	136	2017	2807	1"
900	8	225	400	649	1954	339	389	528	136	2157	3148	1"
1000	6	240	440	699	2160	339	389	528	136	2300	3579	1"
1100	6	240	440	730	2310	339	389	528	136	2513	3779	1 1/2"
1200	6	254	480	775	2551	336	389	659	170	2589	3807	1 1/2"
1300	6	254	480	805	2882	336	389	659	170	3120	4482	1 1/2"
1400	6	279	520	875	3250	336	389	659	170	3525	4952	1 1/2"
1500	6	279	520	925	3695	336	389	659	170	3975	5464	1 1/2"

Table. 11

HYDRAULIC ACTUATOR

The definition variables are as follows:

B = Max. width of the valve (without actuator).

P = Max. height of the valve (without actuator).

THE HYDRAULIC ACTUATOR INCLUDES:

- Hydraulic cylinder
- Yoke

SUPPLY PRESSURE STANDARD:

- 135 bar.

AVAILABLE:

- DN 50 to DN 1500
- Different types and brands available according to customer's requirements.

* Other ND on request.

* Other pressures on request (ΔP)

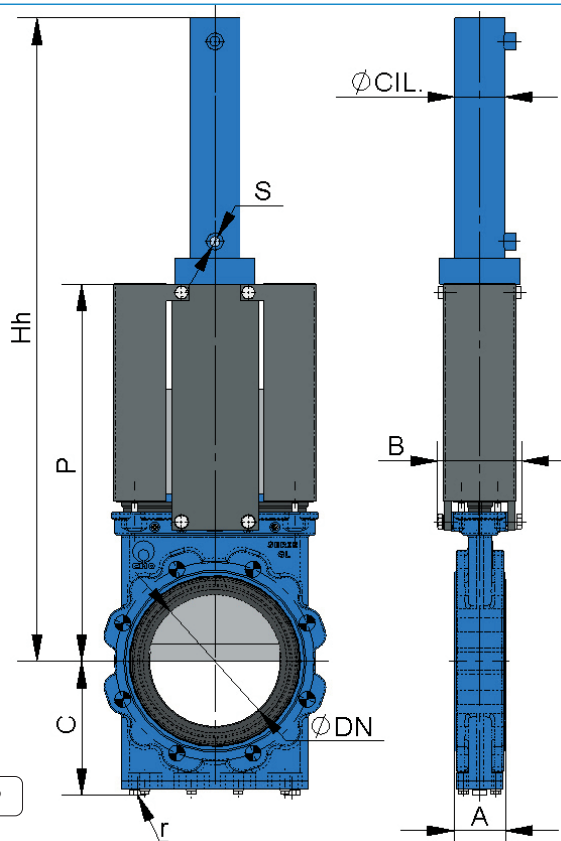

Fig. 22

DN	ΔP (bar)	A	B	C	P	Hh	Ø CIL.	Ø VAST	S (B.S.P.)	OIL (dm ³)	r (B.S.P.)
50	16	54	109	106	280	482	25	18	3/8"	0,04	1/4"
65	16	54	109	113	306	524	25	18	3/8"	0,05	1/4"
80	16	57	109	122	332	566	25	18	3/8"	0,05	1/4"
100	16	57	109	136	368	615	32	22	3/8"	0,11	1/4"
125	16	64	126	153	421	702	40	28	3/8"	0,19	1/4"
150	16	64	126	168	466	789	50	28	3/8"	0,36	1/4"
200	10	76	126	199	565	958	50	28	3/8"	0,47	3/8"
250	10	76	197	234	626	1100	63	36	3/8"	0,91	1/2"
300	10	83	197	272	739	1272	80	36	3/8"	1,73	1/2"
350	10	83	350	297	842	1441	100	45	1/2"	3,1	1/2"
400	10	96	350	330	933	1613	125	56	1/2"	5,55	3/4"
450	10	96	350	355	1019	1766	125	56	1/2"	6,22	3/4"
500	10	121	380	391	1156	1939	125	56	1/2"	6,99	3/4"
600	10	121	400	461	1338	2273	160	70	1/2"	12,57	1"
700	8	182	400	534	1530	2410	160	70	1/2"	14,58	1"
750	8	188	400	559	1637	2576	160	70	1/2"	15,58	1"
800	8	206	400	584	1733	2742	160	70	1/2"	16,69	1"
900	8	225	400	649	1954	3053	200	90	1/2"	29,22	1"
1000	6	240	440	699	2160	3322	160	70	1/2"	20,81	1"
1100	6	240	440	730	2310	3685	200	90	1/2"	35,66	1" 1/2"
1200	6	254	480	775	2551	3919	200	90	1/2"	38,96	1" 1/2"
1300	6	254	480	805	2882	4565	200	90	1/2"	42,1	1" 1/2"
1400	6	279	520	875	3250	5035	220	90	1/2"	55,12	1" 1/2"
1500	6	279	520	925	3695	5545	220	90	1/2"	58,92	1" 1/2"

Table. 12

INFORMATION ON FLANGE DIMENSIONS

EN 1092-2 PN10

DN	●	○	M (Metric)	P	ØK
50	4	-	M 16	14	125
65	4	-	M 16	14	145
80	8	-	M 16	14	160
100	8	-	M 16	14	180
125	8	-	M 16	15	210
150	8	-	M 20	15	240
200	8	-	M 20	17	295
250	12	-	M 20	17	350
300	12	-	M 20	20	400
350	12	4	M 20	21	460
400	12	4	M 24	23	515
450	16	4	M 24	24	565
500	16	4	M 24	25	620
600	16	4	M 27	26	725
700	20	4	M 27	26	840
750	20	4	M 30	26	900
800	20	4	M 30	26	950
900	24	4	M 30	26	1050
1000	24	4	M 33	27	1160
1100	28	4	M 33	27	1270
1200	28	4	M 36	29	1380
1300	28	4	M 36	29	1490
1400	24	4	M 39	30	1590
1500	24	4	M 39	30	1700

Table. 13

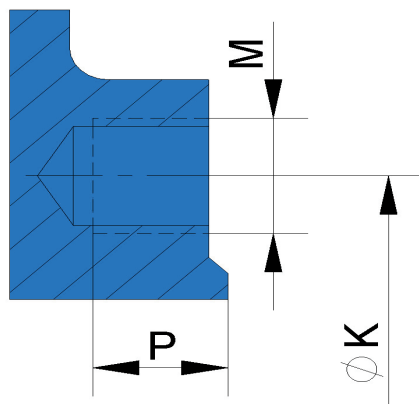

THREADED HOLE DEPTH

Fig. 23

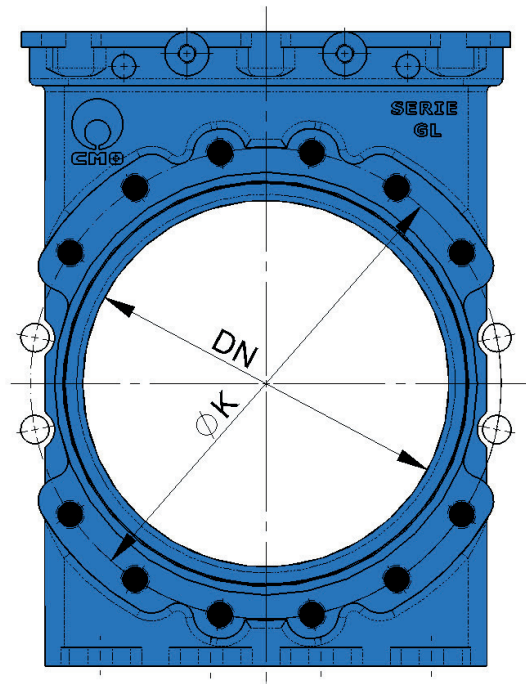

Fig. 22

- BLIND TAPPED HOLE
- THROUGH HOLE

ANSI B16, class 150

DN	●	○	R (UNC)	P	ØK
2"	4	-	5/8"	0,55"	4,75"
2 1/2"	4	-	5/8"	0,55"	5,5"
3"	4	-	5/8"	0,55"	6"
4"	8	-	5/8"	0,55"	7,5"
5"	8	-	3/4"	0,59"	8,5"
6"	8	-	3/4"	0,59"	9,5"
8"	8	-	3/4"	0,67"	11,75"
10"	12	-	7/8"	0,67"	14,25"
12"	12	-	7/8"	0,79"	17"
14"	8	4	1"	0,83"	18,75"
16"	12	4	1"	0,91"	21,25"
18"	12	4	1 1/8"	0,95"	22,75"
20"	16	4	1 1/8"	1"	25"
24"	16	4	1 1/4"	1,02"	29,5"
28"	24	4	1 1/4"	1,02"	34"
30"	24	4	1 1/4"	1,02"	36"
32"	24	4	1 1/2"	1,02"	38,5"
36"	28	4	1 1/2"	1,02"	42,75"
40"	32	4	1 1/2"	1,06"	47,25"

Table. 14

EN 1092-2 PN16

DN	●	○	M (Metric)	P	øK
50	4	-	M 16	14	125
65	4	-	M 16	14	145
80	8	-	M 16	14	160
100	8	-	M 16	14	180
125	8	-	M 16	15	210
150	8	-	M 20	15	240
200	12	-	M 20	17	295
250	12	-	M 24	17	355
300	12	-	M 24	20	410
350	12	4	M 24	21	470
400	12	4	M 27	23	525
450	16	4	M 27	24	585
500	16	4	M 30	25	650
600	16	4	M 33	26	770
700	20	4	M 33	26	840
750	20	4	M 36	26	950
800	24	4	M 36	26	1050
900	24	4	M 39	26	1170
1000	28	4	M 42	27	1370
1100	28	4	M 45	27	1390
1200	32	4	M 45	29	1490
1300	32	4	M 45	29	1590
1400	36	4	M 52	30	1710
1500	24	4	M 39	30	1700

Table. 15

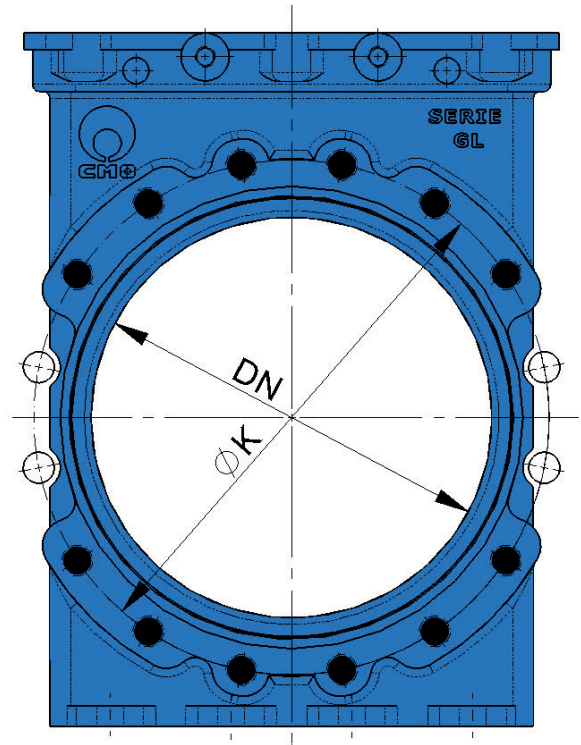
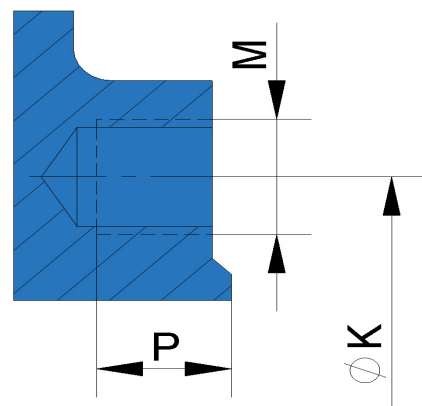

Fig. 23

- BLIND TAPPED HOLE
- THROUGH HOLE



THREADED HOLE DEPTH

Fig. 26

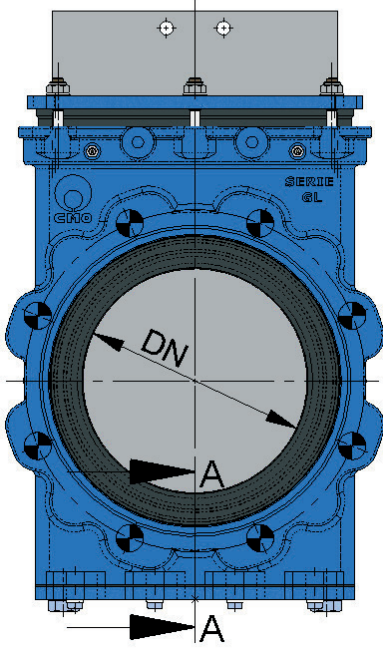
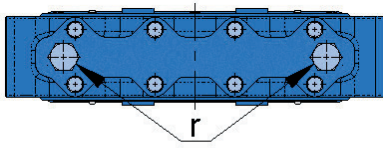

STANDARD VERSION

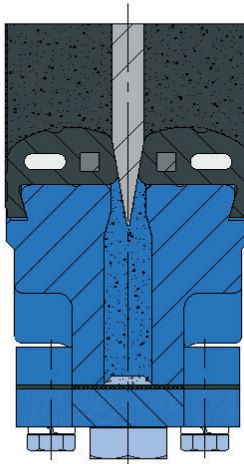

SECTION A-A

DN	r (B.S.P)
50	1/4"
65	1/4"
80	1/4"
100	1/4"
125	1/4"
150	1/4"
200	3/8"
250	1/2"
300	1/2"
350	1/2"
400	3/4"
450	3/4"
500	3/4"
600	1"

Table. 16

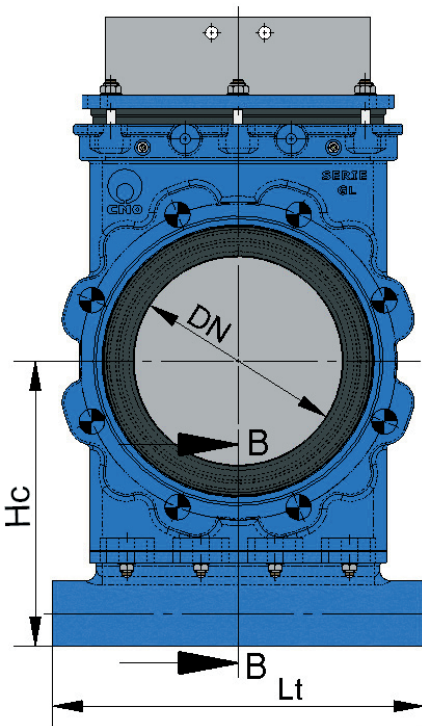

OPTION 1

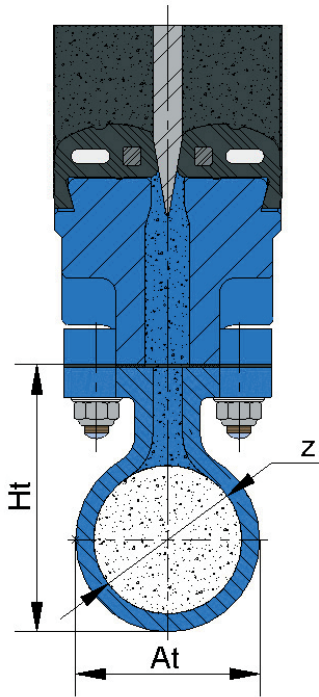

SECTION B-B

DN	Hc	Lt	At	Ht	z (B.S.P.)
50	158	185	42	68	1"
65	168	200	42	68	1"
80	174	220	42	68	1"
100	188	240	42	68	1"
125	208	265	42	73	1"
150	223	290	42	73	1"
200	272	350	42	93	1 3/4"
250	310	400	62	98	1 3/4"
300	348	450	62	98	1 3/4"
350	373	520	62	98	1 3/4"
400	403	560	62	98	1 3/4"
450	428	610	62	98	1 3/4"
500	472	690	70	107	2"
600	542	790	70	107	2"

Table. 17

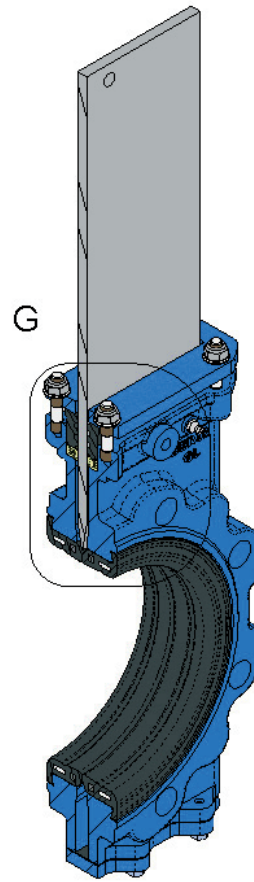
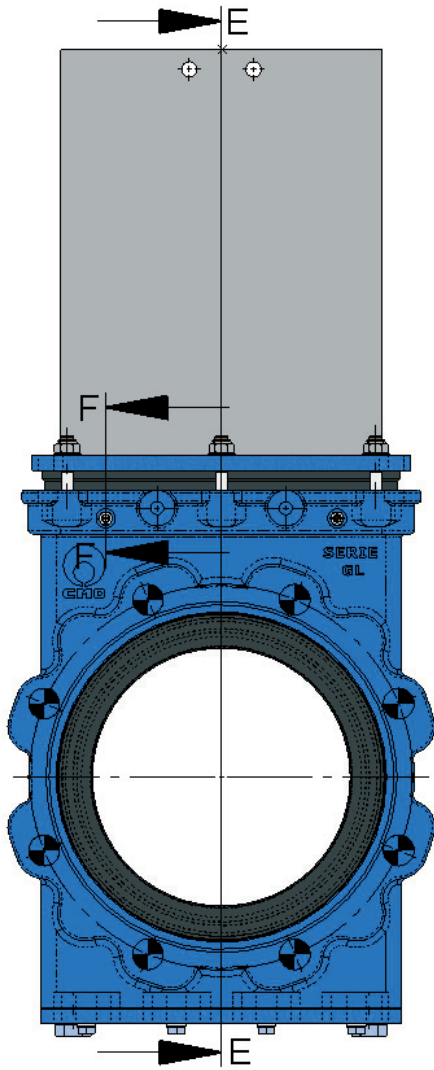

SECTION E-E

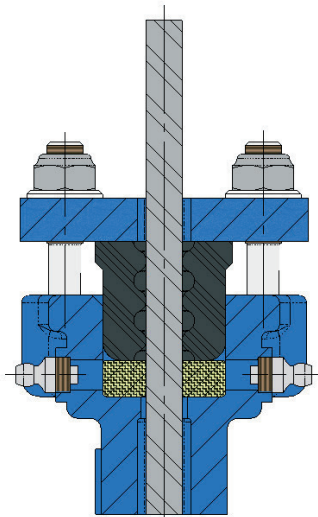

SECTION F-F

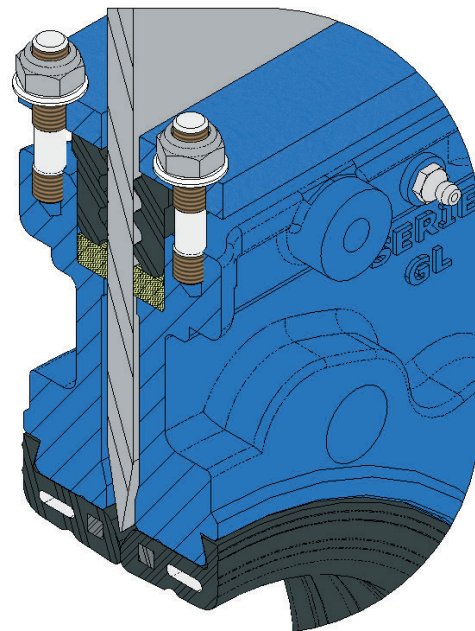

DETAIL G



www.cmovalves.com



CMO VALVES

QMS CERTIFIED BY LRQA
Approval number ISO9001 0035593

CMO VALVES
HEADQUARTERS MAIN
OFFICES & FACTORY

Amategi Aldea, 142
20400 Tolosa
Gipuzkoa (Spain)

Tel.: (+34) 943 67 33 99

cmo@cmovalves.com
www.cmovalves.com

CMO VALVES
MADRID

C/ Rumania, 5 - D5 (P.E. Inbisa)
28802 Alcalá de Henares
Madrid (Spain)

Tel.: (+34) 91 877 11 80

cmomadrid@cmovalves.com
www.cmovalves.com

CMO VALVES
FRANCE

5 chemin de la Brocardière
F-69570 DARDILLY
France

Tel.: (+33) 4 72 18 94 44

cmofrance@cmovalves.com
www.cmovalves.com