

# ED SERIES

## ENGINE DYNAMOMETERS

MAGTROL offers 3 types of dynamometer brakes to absorb load: Hysteresis (**HD Series**), Eddy-Current (**WB Series**) and Magnetic Powder (**PB Series**). Each type of Dynamometer has advantages and limitations and choosing the correct one will depend largely on the type of testing to be performed. With over 50 standard models to choose from, Magtrol Sales professionals are readily available to assist in selecting the proper Dynamometer to meet your testing needs.

### FEATURES

- Maximum Torque: 55 ... 250 lb·in (6.5 N·m ... 28 N·m)
- Hysteresis Braking System
- Motor Testing: from no load to locked rotor
- Standard Torque Units : SI (English & Metric available upon request)
- Accuracy:  $\pm 0.25\%$  (full scale)
- Blower Cooled: to maximize heat dissipation
- Air Flow Sensor: for protection against overheating and operator error
- Specially Reinforced Load Cell: stainless steel pin at contact point prevents premature wear from excess vibration
- Larger Shaft: for additional strength
- Gusseted Pillow Blocks: for additional front and rear support



Fig. 1: ED-715 | Engine Dynamometer

### DESCRIPTION

With Magtrol's Engine Dynamometers, high performance motor testing is available to manufacturers and users of small engines. Magtrol's Engine Dynamometers have been designed to address the severe, high vibration conditions inherent in internal combustion engine testing.

Magtrol's Engine Dynamometers are highly accurate ( $\pm 0.25\%$  of full scale) and can be controlled either manually or via a PC based Controller. For a small engine test stand, Magtrol offers a full line of controllers, readouts and software.

As with all Magtrol Hysteresis Dynamometers, engine loading is provided by Magtrol's Hysteresis Brake, which provides: torque independent of speed, including full load at 0rpm; excellent repeatability; frictionless torque with no wearing parts (other than bearings); and long operating life with low maintenance.

### APPLICATIONS

The Engine Dynamometers are ideally suited for emissions testing as set forth in CARB and EPA Clean Air Regulations. The Dynamometers will offer superior performance on the production line, at incoming inspection or in the R&D lab.

## DYNAMOMETER SELECTION

Magtrol's Hysteresis Dynamometers cover a wide range of Torque, Speed and Mechanical Power ratings. To select the appropriate size Dynamometer for your motor testing needs, you will need to determine the **Maximum Torque, Speed and Power** applied to the Dynamometer.

### MAXIMUM TORQUE

The Magtrol Hysteresis Absorption Dynamometer will develop braking torque at any speed point, including low speed and stall conditions ("0" rpm). It is important to consider all torque points that are to be tested, not only rated torque, but also locked rotor and breakdown torque. Dynamometer selection should initially be based on the maximum torque requirement, subject to determining the maximum power requirements.

### MAXIMUM SPEED

This rating is to be considered independent of torque and power requirements, and is the maximum speed at which the Dynamometer can be safely run under free-run or lightly loaded conditions. It is not to be considered as the maximum speed at which full braking torque can be applied.

**To safely dissipate heat and avoid Dynamometer failure, the maximum power rating is the most important consideration in selecting a Dynamometer.**

## OPERATING PRINCIPLES

Magtrol Hysteresis Dynamometers absorb power with a unique Hysteresis Braking System which provides frictionless torque loading independent of shaft speed. The Hysteresis Brake provides torque by the use of two basic components - a reticulated pole structure and a specialty steel rotor/shaft assembly - fitted together but not in physical contact.

Until the pole structure is energized, the drag cup can spin freely on its shaft bearings. When a magnetizing force from the field coil is applied to the pole structure, the air gap becomes a flux field and the rotor is magnetically restrained, providing a braking action between the pole structure and rotor.

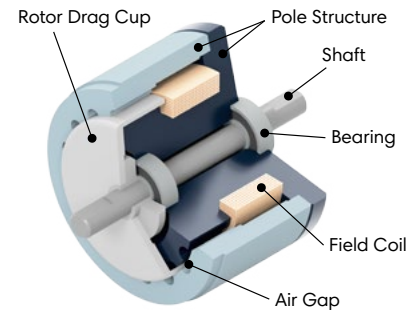

## M-TEST - MOTOR TESTING SOFTWARE



Magtrol's M-TEST Software is a state-of-the-art motor testing program for Windows®-based data acquisition. Used with a Magtrol Programmable Dynamometer Controller, Magtrol M-TEST Software provides the control of any Magtrol Dynamometer and runs test sequences in a manner best suited to the overall accuracy and efficiency of the Magtrol Motor Test System. The data that is generated by Magtrol's Motor Testing Software can be stored,

### MAXIMUM POWER RATINGS

These ratings represent the maximum capability of the Dynamometer Braking System to absorb and dissipate heat generated when applying a braking load to the motor under test. The power absorbed and the heat generated by the Dynamometer is a function of the Torque (**T**) applied to the motor under test, and the resulting Speed (**n**) of the motor. This is expressed in these Power (**P**) formulas:

$$\begin{aligned} \text{SI: } P [W] &= T [N \cdot m] \times n [\text{min}^{-1}] \times (1.047 \times 10^{-1}) \\ \text{English: } P [W] &= T [\text{lb} \cdot \text{in}] \times n [\text{rpm}] \times (1.183 \times 10^{-2}) \\ \text{Metric: } P [W] &= T [\text{kg} \cdot \text{cm}] \times n [\text{rpm}] \times (1.027 \times 10^{-2}) \end{aligned}$$

All of Magtrol's controllers, readouts and software calculate horsepower as defined by 1 [hp] = 550 [lb-ft/s].

Using this definition:  $P [\text{hp}] = P [W] / 745.7$

The Dynamometer's ability to dissipate heat is a function of how long a load will be applied. For this reason, the maximum power ratings given are based on continuous operation under load, as well as a maximum of 5 minutes under load.

displayed and printed in tabular or graphic formats, and can be easily imported into a spreadsheet.

Written in LabVIEW™, M-TEST has the flexibility to test a majority of motor types in a variety of ways. Because of LabVIEW's versatility, obtaining data from other sources (e.g. thermocouples), controlling motor power and providing audio/visual indicators is relatively easy.

Magtrol's M-TEST Software is ideal for simulating loads, cycling the unit under test and motor ramping. Because it is easy to gather data and duplicate tests, the software is ideal for use in engineering labs. Tests can be programmed to run on their own and saved for future use allowing for valuable time savings in production testing and incoming/outgoing inspection.

SYSTEM CONFIGURATIONS

OPEN LOOP SYSTEMS

Magtrol offers both open loop manual test systems and PC-based closed loop test systems. A typical open loop system will consist of a Dynamometer and a Magtrol DSP 7010 Dynamometer Controller. A Magtrol Single or Three-Phase Power Analyzer, which allows for the capturing of volts, amps, watts and power

factor, can be included as an option. An open loop system is often used for quick pass/fail testing on the production line or at incoming inspection. Magtrol's DSP 7010 Dynamometer Controller provides pass/fail testing as a standard feature.

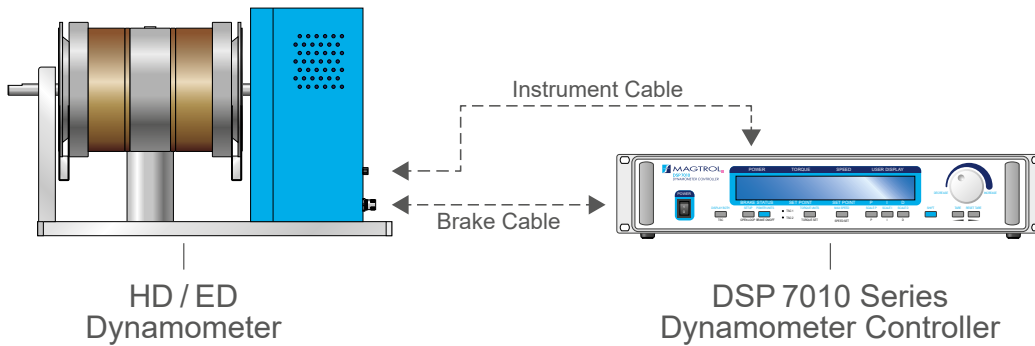

Fig. 2: Dynamometer with DSP 7010 Dynamometer Controller

CLOSED LOOP SYSTEMS

In a closed loop motor test system, data is collected on a PC using Magtrol's M-TEST Software, DSP 7010 Programmable Dynamometer Controller, and requisite interface cards and cables. Magtrol's DSP 7010 Dynamometer Controllers compute and display mechanical power (in horsepower or watts) in

addition to torque and speed. A Single or Three Phase Power Analyzer, a required component in a test system measuring motor efficiency, can be integrated into this system as well as Magtrol's Temperature Testing Hardware.

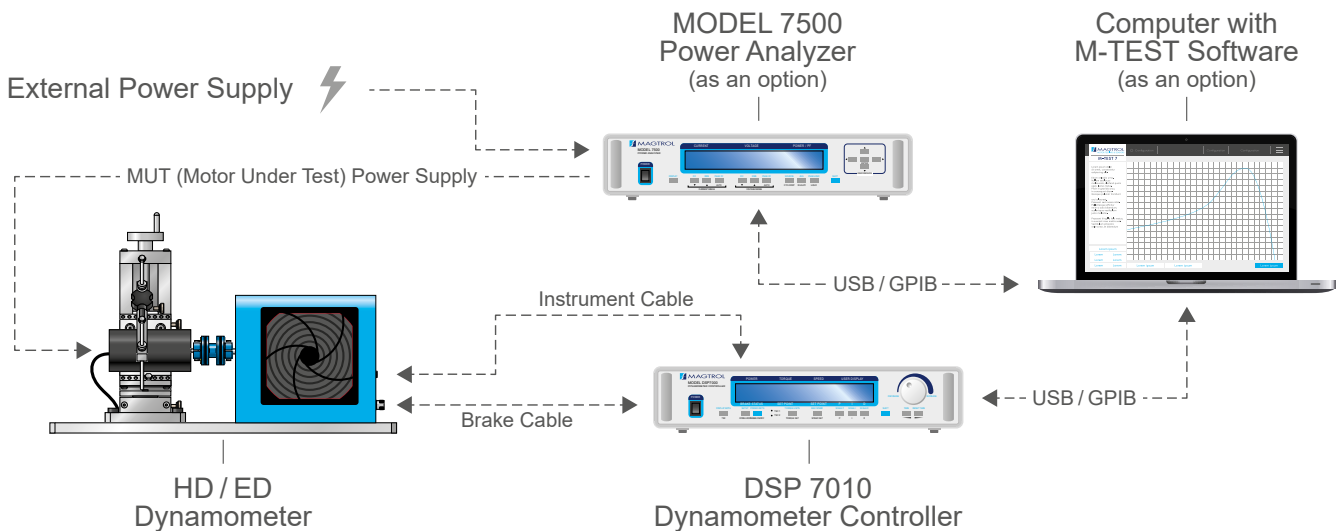

Fig. 3: Dynamometer with MODEL 7500 Power Analyzer, DSP 7010 Dynamometer Controller and M-TEST Software

SPECIFICATIONS

HYSTERESIS DYNAMOMETER RATINGS

MODELS	TORQUE MEASURE UNIT CODE <sup>a)</sup>	MAXIMUM TORQUE RANGE	DRAG TORQUE DE-ENERGIZED AT 1000 rpm	NOMINAL INPUT INERTIA		MAX. POWER RATINGS		MAXIMUM SPEED rpm	BRAKE COOLING METHOD
		N·m	mN·m	lb·ft·s <sup>2</sup>	kg·m <sup>2</sup>	5min W	CONTINUOUS <sup>c)</sup> W		
ED-715	5C	6.2	35	1.27 × 10 <sup>-3</sup>	1.72 × 10 <sup>-3</sup>	3400	3000	25000	Blower <sup>b)</sup>
ED-815	5C	28.0	140	9.61 × 10 <sup>-3</sup>	1.30 × 10 <sup>-2</sup>	7000	6000	12000	Blower <sup>b)</sup>

a) All -5C dynamometers are 5 Volt Output.  
Please, contact our sales representative for 6C (English units), 7C (Metric units) or 8C (SI units) specifications.  
b) Blower is included

c) Operating at the continuous power rating for periods of up to 4 hours is acceptable. However, operating for extended periods at high temperatures will result in premature component and bearing failure. Limiting the length of the cycle and the component temperatures will guard against premature failure. Where continuous duty is desired for longer time intervals, component temperatures should be maintained less than 100°C.  
Monitoring the outside brake surface temperature is a sufficient reference.

ELECTRICAL POWER

MODELS	VOLTAGE	VA
ED-815-XC1	120V	130
ED-815-XC2	240V	

POWER ABSORPTION CURVES

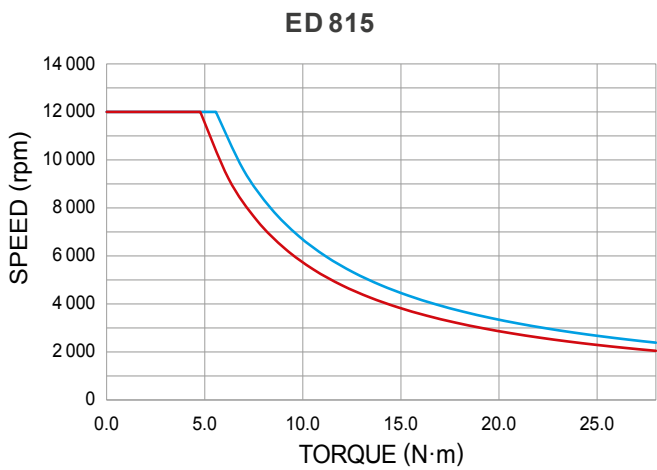
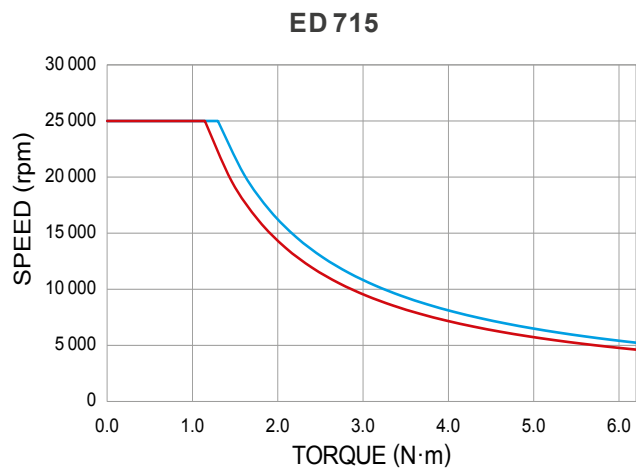
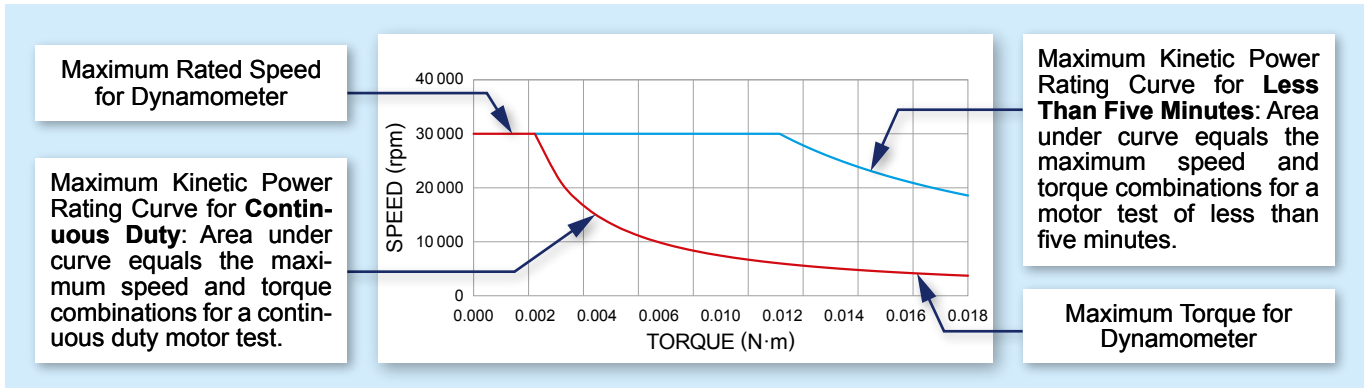

DIMENSIONS

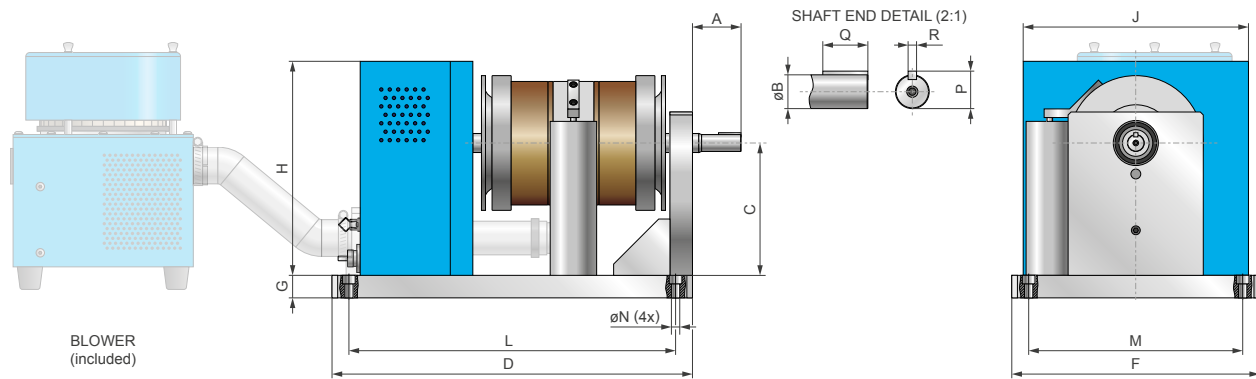

NOTE: Original dimensions are in English units. Dimensions converted to Metric units have been rounded and are for reference only.

MODEL	units	A	øB	C	D	E	F	G	H	L <sup>a)</sup>	M <sup>a)</sup>	øN	P	Q	R	Weight
ED-715	in	1.72	0.7490 0.7495	6.87	16.00	18.13	11.00	1.00	10.50	14.50	9.50	0.37	0.64	1.00	0.187	75 lb
	mm	43.7	19.025 19.037	174.5	406.4	460.5	279.4	25.4	266.7	368.3	241.3	9.4	16.35	25.4	4.83	34 kg
ED-815	in	3.02	1.4995 1.5000	11.00	23.00	23.27	17.00	2.00	16.63	20.80	15.00	5/8-11	1.287	2.00	0.375	285 lb
	mm	76.7	38.087 38.100	279.4	584.2	591.1	431.8	50.8	422.4	528.3	381.0	THD	32.7	50.8	9.53	129.3 kg

a) These dimensions represent the distance between mounting holes. There are four (4) mounting holes on each base plate.

BLOWERS

BLOWER POWER

MODEL	VOLTAGE	VA	MODEL	VOLTAGE	VA
BL-001	120 V	600	BL-002	120 V	1000
BL-001A	240 V	500	BL-002A	240 V	

- Models ED-715 include the BL-001 blower.
- Models ED-815 include the BL-002 blower.

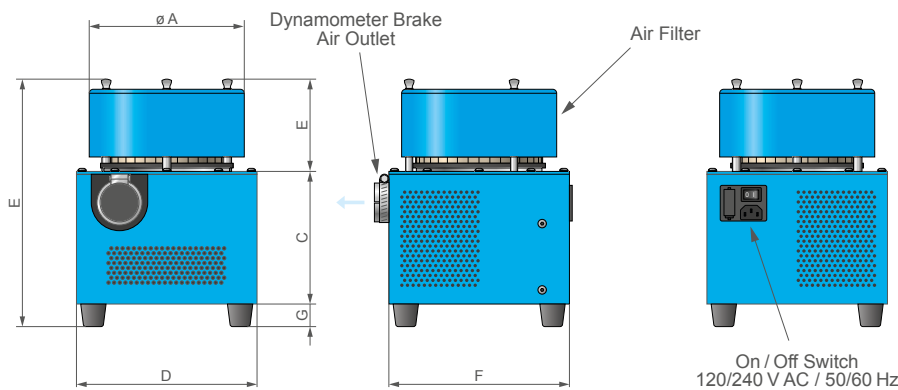

Allow approximately 6 in to 8 in (152 mm to 203 mm) between rear of dynamometer base plate and blower for connection hardware. Required hardware is supplied with the dynamometer.

BL-002 Blower has two filter elements.

MODEL	units	øA	B	C	D	E	F	G	Weight
BL-001	mm	178	279	254	203	102	203	25	3.9 kg
	in	7	11	10	8	4	8	1	8.5 lb
BL-002	mm	178	279	254	381	102	308	25	8.1 kg
	in	7	11	10	15	4	12	1	18 lb

NOTE: 3D STEP files of most of our products are available on our website: [www.magtrol.com](http://www.magtrol.com) ; other files are available on request.

## CUSTOM MOTOR TEST SYSTEM

HD Series Hysteresis Dynamometers can be incorporated into a Customized Motor Test System (CMTS).

These PC based, turn-key systems are custom designed and built to meet specific user requirements.

Various devices such as dynamometer controllers, power analyzers or other customized devices can be easily integrated into a 19" rack system (in an external cabinet or directly in the table).

These systems integrate specific software (such as M-TEST) to facilitate the measurement process.

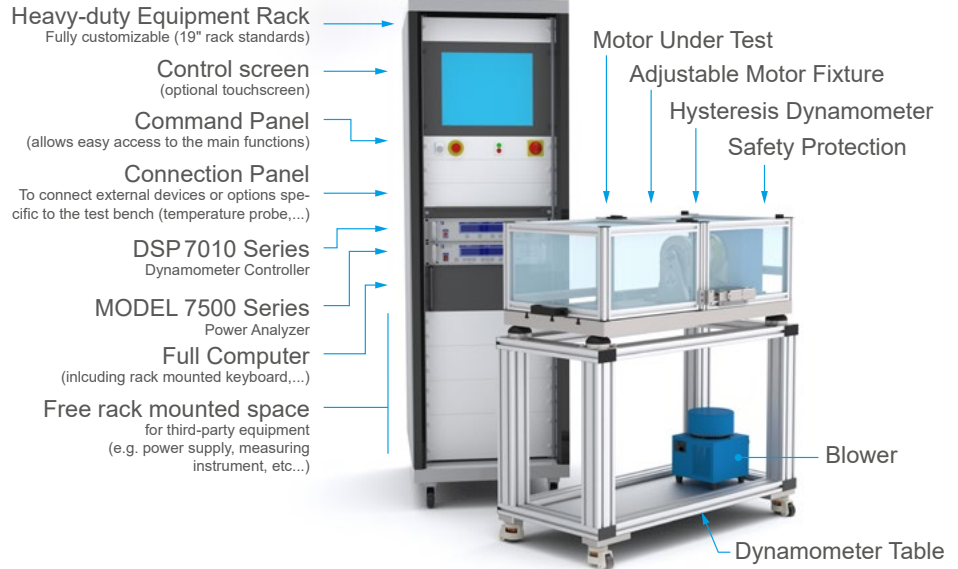

## DYNAMOMETER OPTIONS

### ENCODER OPTIONS FOR LOW SPEED TESTING

For low speed motors, such as gear motors with maximum speeds of less than 200 rpm, Magtrol offers additional encoder options that allow for increased resolution of the speed signal.

### T-SLOT BASE PLATE

To accommodate Magtrol AMF-3 Adjustable Motor Fixtures, a grooved base plate with three M12 T-slots, one centered and two 250mm apart, is available on all HD-8XX series dynamometers.

## CUSTOM DYNAMOMETER

### MECHANICAL MODIFICATIONS

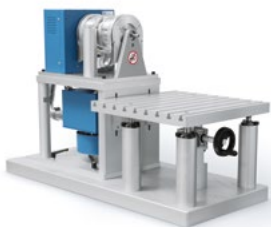

Fig. 4: Example of mechanical modifications

Magtrol is highly experienced and qualified in the customization of its products. We can provide customized base plates, riser blocks and shaft modifications. Our specialized salesmen and technicians are at your service to help you find the best configuration for your project. Thank you for contacting us, we will be glad to advise you.

## ORDERING INFORMATION

MODEL NUMBER	ED- _ _ _ - 5C _ - 0 X _ X <sup>a)</sup>
--------------	--

**715, 815** : Engine Dynamometers

**1** : 120 VAC  
**2** : 240 VAC

**0** : 60 PPR speed encoder (standard)<sup>b)</sup>  
**3** : 60 + 600 PPR speed encoder<sup>b)</sup>  
**4** : 60 + 6000 PPR speed encoder<sup>b)</sup>

- a) In case of special design the 4 last digits will be specific; please contact our sales representative
- b) PPR means Pulse Per Revolution

Example: ED Series Dynamometer, Model 715, supply in 240VAC, 60 PPR encoder would be ordered: **ED-715-5C2-0X0X**

## CABLE ASSEMBLY

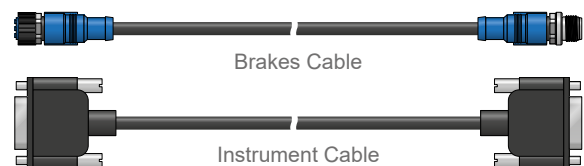

ORDERING NUMBER	88M _ _ _ - _ _ _ _
-----------------	---------------------

**367** : Brake Cable  
**368** : Instrument Cable

**0150** : Cable length 1.5m<sup>a)</sup>  
**0500** : Cable length 5m<sup>a)</sup>

- a) Other length available on request

## SYSTEM OPTIONS AND ACCESSORIES

### DSP 7010 - DYNAMOMETER CONTROLLERS

Magtrol's MODEL DSP7010 Series Dynamometer Controller employs state-of-the-art Digital Signal Processing Technology to provide superior motor testing capabilities. Designed for use with any Magtrol Hysteresis, Eddy-Current or Powder Dynamometer, Magtrol In-Line Torque Transducer or auxiliary instrumentation, the DSP7010 can provide complete PC control via the USB or IEEE-488 interface. With up to 500 readings per second, the DSP7010 is ideally suited for both the test lab and the production line.



Fig. 5: DSP 7011 | Programmable Dynamometer Controllers

### MODEL 7500 - POWER ANALYZERS

The Magtrol MODEL7500 Power Analyzer is an easy-to-use instrument ideal for numerous power measurement applications. From DC to 80kHz, the MODEL 7500 measures volts, amps, watts, volt-amps, frequency, crest factor, Vpeak, Apeak and power factor in one convenient display. They may be used either as stand-alone instruments or in conjunction with any Magtrol Hysteresis, Eddy-Current or Powder Brake Dynamometer; any Magtrol Dynamometer Controller and M-TEST Software for more demanding motor test applications.



Fig. 7: MODEL 7510 | Power Analyzers

### WB & PB SERIES - DYNAMOMETER



Fig. 6: 1PB115 | Powder Dynamometer

The WB Series (eddy current) and PB Series (magnetic powder) dynamometers are particularly suitable for demanding applications requiring low (PB) to high (WB up to 65000 rpm) speeds. The PB brakes will develop their nominal torque at standstill, while the WB

brakes develop a braking torque proportional to the speed and their maximum torque is reached at nominal speed. The brake is cooled by water circulating in the stator. As a result, these dynamometers are able to dissipate high continuous loads (up to 140kW). The WB and PB dynamometers incorporate a torque measuring system which has an accuracy of  $\pm 0.3\%$  to  $\pm 0.5\%$  at full scale.

### TAB SERIES - DYNAMOMETER TABLES

Test from a stationary position or move a dynamometer to alternate testing stations with ease with Magtrol's Dynamometer Table. The stand is designed from lightweight aluminum with casters for smooth mobility, and is sturdy enough to support even the heaviest of Magtrol dynamometers. The design can be retrofitted to any Magtrol dynamometer and is easily reconfigured for added versatility.

### AMF SERIES - MOTOR FIXTURES

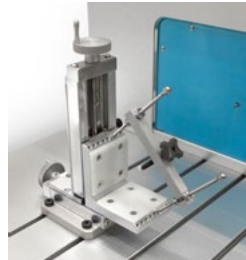

Positioning and alignment have a great influence on the measured parameters (friction torque). MAGTROL strongly recommends a support specifically dedicated to the products to be tested to ensure the best positioning tolerances in X-Y, and its repeatability.

Alternatively, Magtrol AMF Series (Adjustable Motor Fixtures) can be used. These extremely versatile fixtures can accommodate motors up to 101 mm (4") in diameter. It enables easy motor centering during testing, but does not have centering references.



Fig. 8: TAB Series | Dynamometer Tables