

MEDENUS



Gas Pressure Regulation



Safety Shut-Off Valve S 50

Product information



EN

Table of Contents

Application, Characteristics, Technical Data	4
Application	4
Characteristics	4
Type of models / Options (see page 10)	4
Technical data	5
Structure and function	6
Sectional view	7
SSV setpoint spring table - control device	8
Dimensions, Connection, and Weight	9
Dimensional drawing	9
Dimensions and weight	9
Connection of the measuring lines and breather lines	9
Types of Models / Options	10
Design	11
Properties of Gases	11
Order Data	12
Notes	13
Contact	14
Notes	16



ATTENTION

Observe the following publications in relation to installation, start-up and maintenance:
 DVGW - work sheets G 491 and G 600
 Operating and Maintenance Instructions S50

List of abbreviations and formula symbols

AC	Accuracy class	$p_{ds\ o}$	Upper SSV response pressure	$W_{ds\ o}$	Upper spring adjustment range (SSV)
AG_o	Upper response pressure group	$p_{ds\ u}$	Lower SSV response pressure	$W_{ds\ u}$	Lower spring adjustment range (SSV)
AG_u	Lower response pressure group	$p_{f,max}$	Maximum closing pressure	Δp	Pressure difference from inlet pressure to outlet pressure
BV	Breather valve	PS	Maximum allowable pressure	Δp_{wo}	Min. re-engagement difference between upper response pressure and normal operating pressure
GPR	Gas pressure regulator	p_u	Inlet pressure	Δp_{wu}	Min. re-engagement difference between lower response pressure and normal operating pressure
HDS	High-pressure spindle	Q_n	Standard volumetric flow rate	ρ_n	Gas density
K_G	Valve flow rate coefficient	RE	Diaphragm assembly		
p	Pressure	RSD2	Throttle valve		
p_d	Outlet pressure	SSV	Safety shut-off valve		
p_{df}	SRV closing pressure	SRV	Safety relief valve		
p_{do}	SRV opening pressure	SG	Closing pressure group		
p_{ds}	Setpoint of the response pressure	t_{Gas}	Gas inlet temperature		
		VS	Valve seat		
		w_d	Outlet gas velocity		
		w_u	Inlet gas velocity		

Application, Characteristics, Technical Data

Application

Safety shut-off valve (SSV), direct-acting (operating without auxiliary power), for systems acc. to DVGW work sheets G 491 (A) and G 600 (A) (TRGI)

Can be used for the gases defined in DVGW work sheet G 260 / G 262 and neutral non-aggressive gases. (other gases on request)

Characteristics

- Integral pressure-tight version (IS)
- High flow rate capacity
- Open-air model

Type of models / Options (see page 10)

- with AV breather valve
- with electric position indicator SSV 'Closed' via inductive proximity initiator or via reed contact
- with SSV electromagnetic remote release when power is applied or in case of power failure
- with SSV manual release
- oxygen model
- hydrogen model

Response pressure groups

Lower response pressure AG_u in command area w_{dsu}	AG_u
10 mbar to 50 mbar	20
> 50 mbar	10

Upper response pressure group AG_o in command area w_{dso}	AG_o
50 mbar to 500 mbar	10
> 500 mbar	5

Technical data

Type	S 50
Model	Integral pressure-tight (IS)
Max. allowable pressure PS	3 bar
Nominal width	Rp 1" (DN 25), Rp 1½" (DN 40), Rp 2" (DN 50) (NPT thread on request)
Standard volumetric flow rate $Q_{n,max}$	Rp 1": 100m³/h, Rp 1½": 300m³/h, Rp 2": 300m³/h
Type of connection	Internal thread acc. to EN 10226-1
Material	
Housing / actuator housing/ Control device housing	Al cast alloy DIN EN 1706-AC-42100 ST6
Corrosivity category	DIN EN ISO 12944-2
C1 to C5-I	without additional coatings
C5-M	an epoxy resin coating is recommended (see page10)
Temperature range, Class 2 (operating/ambient temperature)	-20°C to +60°C
Function, strength and tightness	DIN EN 14382
CE mark acc. to PED/ PIN number	CE-0085-BS0420
Ex protection	The mechanical parts of the device do not have any potential ignition sources of their own and therefore do not fall within the scope of ATEX 95 (94/9/EC). Electrical components fitted to the device comply with the ATEX requirements.

Preferred installation position

The safety shut-off valves (SSV) shall be installed in the pipeline preferably in horizontal position. For all nominal widths, the direction of flow is indicated by an arrow on the housing.



Installation upside down only after consultation with Medenus GmbH

Note: Observe the following documents in relation to installation, start-up, and maintenance:

- DVGW - work sheets G 491 and G 600
- Operating and Maintenance Instructions S50

CE EAC

Structure and function

The safety shut-off valve S 50 shuts off the gas flow when the outlet pressure in the regulation section exceeds or falls below a certain response pressure. To this end, the outlet pressure to be monitored is passed on to the SSV control device via a separate measurement line. As a function of the change in pressure, the diaphragm in the control device is raised or lowered. When the outlet pressure in the regulation section falls below the lower switch-off point or exceeds the upper switch-off point, the switch socket connected to the SSV diaphragm will move to the corresponding disengaging position, the balls of the engaging mechanism will release the SSV screw spindle, and the closing spring will press the SSV valve plate against the valve seat. The SSV actuator shuts off the gas flow gas-tight.

The SSV can only be opened by hand and engaged in the open position. To do so, the outlet pressure at the measuring point must be lowered below the upper response pressure or raised above the lower response pressure by at least the re-engaging differential amount (Δp).

The SSV can, except where otherwise stipulated in specific national legislation, be used in either functional class A (with diaphragm rupture protection) or B (without diaphragm rupture protection).

There is also the option of using a remote display for the SSV position "CLOSED" and a manual and remote release when power is applied or in case of power failure.

Installation example

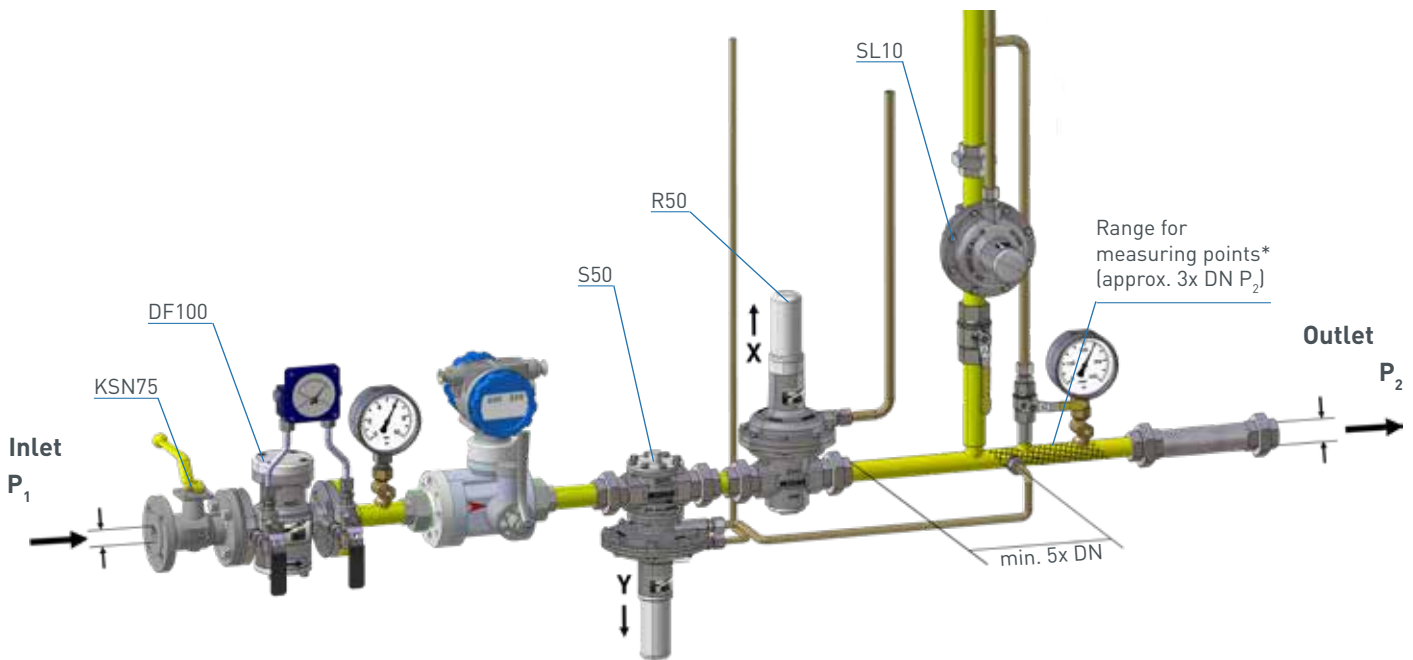

*) Recommended max. velocity at the measurement line port 25 m/s

Sectional view

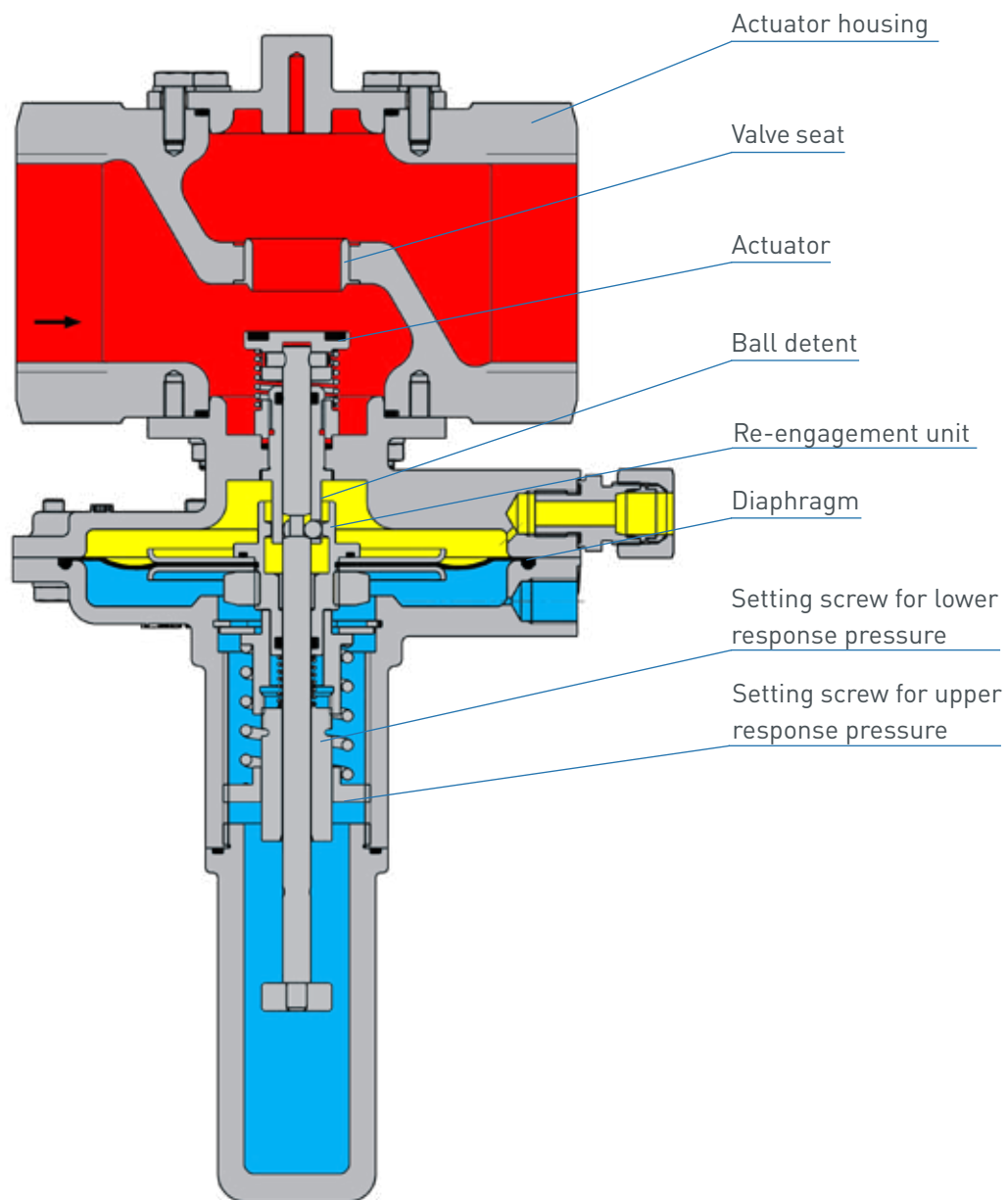

SSV setpoint spring table - control device

S50: Rp 1"-2"

Spring data		MD**				MD-R**			
		to $W_{ds\ o}$ 300 mbar		Upper response pressure		to $W_{ds\ o}$ 3500 mbar		Upper response pressure	
Spring no.	Color [RAL]	$W_{ds\ u}$ [mbar]	Δp_{wu} [mbar]	w_{dso} [mbar]	Δp_{wo} [mbar]	$W_{ds\ u}$ [mbar]	Δp_{wu} [mbar]	w_{dso} [mbar]	Δp_{wo} [mbar]
FE 900	1028	1 - 8	20			35 - 50	50		
FE 901 VA	3002	6 - 17	20			50 - 80*	50		
FE 902 VA	6010	12 - 24*	20			70 - 105	50		
FE 903	5015	22 - 40	20			100 - 140	50		
FE 904 VA	9005	30 - 50	20			110 - 160	50		
FE 905 VA	9010	45 - 70	20			150 - 205	50		
FE 906	4002	65 - 100	20			200 - 300	50		
FD 910	1028			20 - 40	20			90 - 125	50
FD 911	3002			35 - 70	20			120 - 210	50
FD 912	6010			65 - 110	20			200 - 330	50
FD 913	5015			100 - 160	20			285 - 460	50
FD 914	9005			150 - 235	20			450 - 680	50
FD 915	9010			225 - 300	20			640 - 1040	50
FD 916	3002							1030 - 1480	50
FD 917	5010							1450 - 2200	50
FD 918	9006							1900 - 3500	50
FD 919	4002								

*) Standard spring

**) If the control device is set up simultaneously for the upper and lower set pressure (functional class A) the difference between the setpoints of the upper and lower response pressure ($p_{ds\ o}$ and $p_{ds\ u}$) and the outlet pressure p_d must be at least " $\Delta p_{wo} + 10\%$ " or " $\Delta p_{wu} + 10\%$ ". Otherwise it cannot be guaranteed that the control device will re-engage.

Dimensions, Connection, and Weight

Dimensional drawing

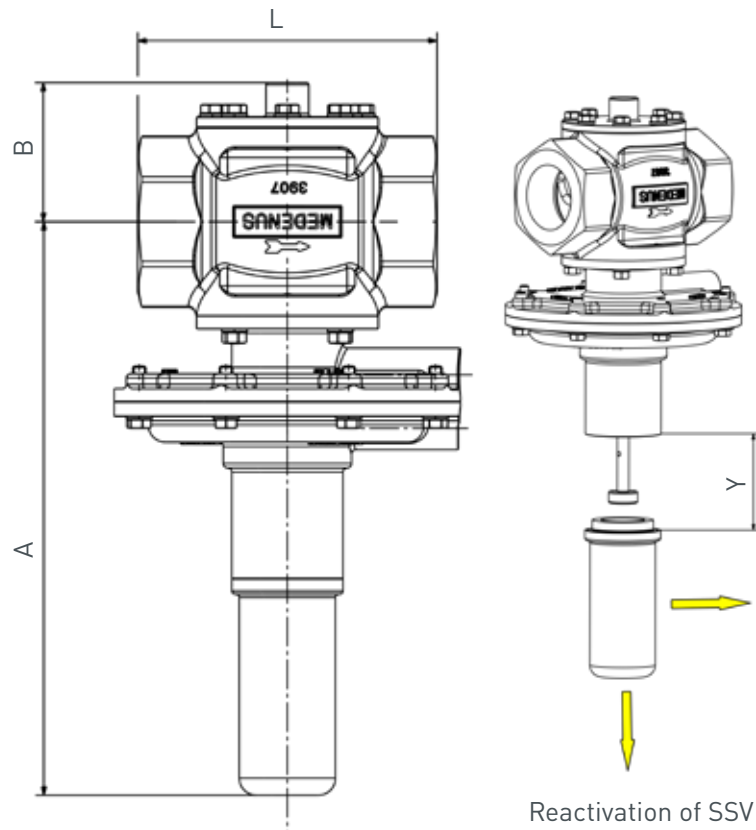

Dimensions and weight

Nominal width \ Dimensions	DN 25	DN 40	DN 50
	Rp 1"	Rp 1 1/2"	Rp 2"
A [mm]	261	268	268
B [mm]	59	65	65
L [mm]	100	140	160
Y [mm]	100	100	100
Weight [kg]	2.5	3.5	4.0

Connection of the measuring lines and breather lines

Nominal width	Measurement line	Breather line
DN 025 Rp 1"	Connection* for: tube 12 x 1.5 (thread G 1/4)	
DN 040 Rp 1 1/2"		
DN 050 Rp 2"		

Types of Models / Options

AV breather valve

The AV breather valve is used as for securing the installation room against inadmissible escape of gas from diaphragm comparator compartments of safety shut-off valves. In case of a defect, the impermissible escape of gas into the surrounding atmosphere is limited to a maximum of 30l/h (air).

It also serves as a substitute for an expensive and complex installation of breather lines.

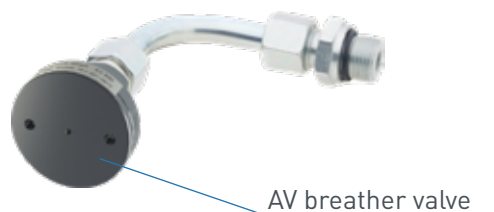

(Option not available for hydrogen version H₂)

Reed contact / inductive transmitter

Reed contacts and inductive transmitters are used to monitor the position (closed or open position) of the safety shut-off valve via remote display.

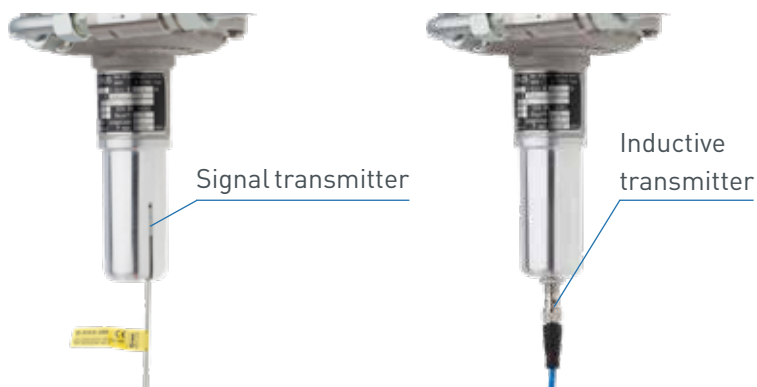

SSV manual and remote release

The direct-acting safety solenoid valve is used as electromagnetic remote release for closing the safety shut-off valve when power is applied or in case of power failure.



Epoxy resin coating in RAL colors

To protect the gas pressure regulator from external influences, starting from a corrosivity category C5-M we recommend an epoxy resin coating.



Types of models

Oxygen version O₂

Hydrogen version H₂ (with helium leak test)



Design

Checking the gas velocities

$$w = 380 \cdot Q_n / (DN^2 \cdot p_{abs})$$

Note: The factor 380 refers to an operating gas temperature from approx. 15°C to 20°C. For other temperatures, the velocity must be corrected as follows: $w_{corr} = w \cdot (t_{gas} + 273.15) / 290$

Recommended max. gas velocity at the inlet flange:
50 - 70 m/s Lower value for redirections upstream of the SSV

Example:

Inlet and outlet nominal width of the pipeline according to the selected device: 25 mm

$$Q_n = 70 \text{ m}^3/\text{h} \quad p_u / (p_d) = 5 \text{ bar}$$

$$w_u = 380 \cdot 70 / (25^2 \cdot 6) = 7.1 \text{ m/s}$$

Determining the upper response pressure

Outlet pressure P_d (mbar)	Upper response pressure W_{dso}
≤ 200	$P_d + 100 \text{ mbar}$
$> 200 - \leq 800$	$P_d \times 1.5$
$> 800 - \leq 1600$	$P_d \times 1.3$
> 1600	$P_d + 500 \text{ mbar}$

Pressure loss formula

Calculation pressure absolute ($p_u + 1 \text{ bar}$) = $p_{u,abs}$

$$\Delta p = \left(\frac{Q_n}{K_G} \right)^2 \times \frac{1000}{p_{u,abs}}$$

Properties of Gases

- for natural gas ($\rho_n = 0.83 \text{ kg/m}^3$; $t = 15^\circ\text{C}$)
- f - natural gas conversion factor- L

Gas	f	Hs,n [kWh/m ³]	Gas	f	Hs,n [kWh/m ³]
Acetylene	0.84	16.25	Sewage gas	0.84	
Ammonia	1.04	4.83	Carbon monoxide	0.81	3.51
Butane	0.55	37.23	Carbon dioxide	0.65	-
Chlorine	0.51	-	Air	0.80	-
Landfill gas	approx. 0.80		Methane	1.08	11.06
Natural gas L	1.00	9.77	Propane	0.64	28.03
Natural gas H	1.03	11.45	Oxygen	0.76	-
Ethane	0.78	19.55	Sulphur dioxide	0.53	-
Ethylene	0.97	16.516	Nitrogen	0.81	-
Mine gas (30% CH ₄)		0.86	Hydrogen	3.04	13.43
Helium	2.15	-			

Order Data

Example:

Safety shut-off valve: S50/Rp1"/MD-R/left/BV/N/H/WAZ/So

Order code:	S50	Rp1"	MD-R	-	left	BV	N	H	WAZ	So
Order selection	Designation									
Type										
S50	S50	S50								
DN - Nominal width	Table p. 9	Rp1"								
SSV										
with control device MD	MD									
with control device MD-R	MD-R		MD-R							
SSV functional class										
A	-			-						
B	B									
Direction of flow										
Right (from left to right)	-									
Left (from right to left)	left				left					
SSV valve accessories	Fig. p. 10									
without SSV valve accessories	-									
Breather valve	BV					BV				
Electrical position indicator, SSV "Closed"	Fig. p. 10									
without electrical position indicator	-									
with ... , via proximity switch	N						N			
with ... , via Reed contact	R									
SSV release	Fig. p. 10									
without release	-									
with manual release	H							H		
with electromagnetic remote release, when power is supplied	SG									
with electromagnetic remote release, in case of power failure	SA									
Acceptance test certificate to EN 10204/3.1										
without acceptance test certificate	-									
with acceptance test certificate	WAZ								WAZ	
Special model	So									So
- Coating with epoxy resin in RAL colors										
- Oxygen model										

DN - Nominal width

Type	Rp 1"	Rp 1½"	Rp 2"
S50	X	X	X

In every selection group, only one option can be selected in each case.

Notes

A series of horizontal dotted lines for writing notes.

Contact



Management
ALEXANDER CHRISTIANI

Phone: +49 (0) 2761 / 82788-18
Mail: a.christiani@medenus.de



Technical Inside Sales Department
MINDAUGAS PECKAITIS

Phone: +49 (0) 2761 / 82788-23
Mail: m.peckaitis@medenus.de



Head of Inside Sales Department
MANUEL SCHEPP

Phone: +49 (0) 2761 / 82788-20
Mobile phone: +49 (0) 170 / 6355309
Mail: m.schepp@medenus.de



Inside Sales Department
SEBASTIAN HUCKESTEIN

Phone: +49 (0) 2761 / 82788-11
Mail: s.huckestein@medenus.de



Inside Sales Department
STEFANIE MÜLLER

Phone: +49 (0) 2761 / 82788-13
Mail: s.mueller@medenus.de



If you want to know more about solutions from MEDENUS for the gas industry, please contact your local contact person or go to our internet site at www.medenus.de

Trade representation worldwide
medenus.de/de/kontakt.html

MEDENUS
Gas-Druckregeltechnik GmbH

Im Langen Feld 3
D-57462 Olpe
Phone: +49 (0)2761 82788-0
Fax: +49 (0)2761 82788-9
Mail: info@medenus.de
Internet: www.medenus.de



THE MEDENUS PLUS

10 reasons for good business relations

1. Consultancy expertise and quality standards developed over decades
 2. Broad and proven standard range of feedback controllers
 3. Modern, fast and efficient production for series products and for individual orders
 4. Customer-specific design of pressure regulators and vacuum regulators and special designs
 5. Guaranteed deadline compliance with a delivery deadline guarantee
 6. Fast response time in all matters
 7. Sufficiently large parts storage for production and spare parts
 8. Customer-specific theory & practice training courses
 9. Modular design right across the entire product range to facilitate optimized handling of spare parts
 10. 100% Made in Germany
-

In the download area of our homepage, this document is available in different languages. You can use the following QR codes and links to go directly to this document in your language.



Deutsch:

http://medenus.de/files/upload/downloads/S50/Pi_S50_de.pdf



English:

http://medenus.de/files/upload/downloads/S50/Pi_S50_en.pdf



MEDENUS Gas-Druckregeltechnik GmbH

Phone +49 (0)2761 82788-0

Fax +49 (0)2761 82788-9

Im Langen Feld 3 / D-57462 Olpe

info@medenus.de

www.medenus.de

EN