



**Graphite India Ltd**

## **IGE Division**

Heat and Mass Transfer  
Equipment, Systems and  
Services for Corrosive  
Chemical Applications

- Thermal and Process Design
- Engineering
- Project management
- Manufacturing
- After Sales Service

**Everything under one roof**

**References in more than 50 countries**

# Overview

Since 1983, **Impervious Graphite Equipment (IGE) Division** manufactures impregnated graphite heat & mass transfer equipment as well as systems employed in corrosive chemical applications.



## CERTIFICATIONS

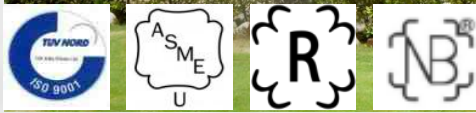

- Graphite is an allotrope of carbon (softer than diamond but fragile) having crystalline form categorized as a non metal still conducts electricity.
- Synthetic graphite is impregnated with resins (Phenolic or PTFE) and is suitable for handling various corrosive applications.
- It offers excellent corrosion resistance to many chemicals, possesses good thermal conductivity and resistance to thermal and mechanical shocks.

## Impregnated Graphite Properties

Properties	Blocks	Tubes
Density gm/cc	1.8-1.9	1.8-1.9
Thermal Conductivity W/m°C	170-213	74-89
Tensile Strength N/mm <sup>2</sup>	20-24	27-33
Flexural Strength N/mm <sup>2</sup>	30-36	45-56
Compressive Strength N/mm <sup>2</sup>	60-70	75-90
Co-efficient of thermal expansion mm/mm/°C x 10 <sup>-6</sup>	3-4	3-4
Permeability cm <sup>2</sup> /sec x 10 <sup>-6</sup>	2-3	3-4

General Suitability: Phenolic Impregnated Graphite: 190° C, PTFE Impregnated Graphite: 230° C

GRAPHITE INDIA LIMITED is based in India also having multiple product lines such as Graphite Electrodes for steel industry, Special Purpose Graphite, Glass Fibre Reinforced Plastics Pipes and Tanks, etc.



# Product Range

## Equipment

- Graphite Heat Exchangers (Block / Shell & Tube)
- Graphite Columns
- Graphite Ejectors
- Graphite Pump
- Acid Dilution & Cooling unit
- Sulphuric acid Concentration unit

## Process Systems

- HCl Synthesis unit
- HCl Absorption unit
- Dry HCl gas generation unit

## Services

- Engineering
- Maintenance and Repair
- Supervision of Erection & Commissioning
- Troubleshooting

Specific Product Requirements can be met like:

- U stamp
- "CE" marking as per PED/2014/68/EU
- Japan Pressure Vessel Class
- KOSHA
- DOSH
- EAC
- SANS 347
- And many more

Products are well established in sectors like:

Chlor-Alkali	Chlorinated Organic Chemicals	Drugs and Pharmaceuticals (API)	Agrochemicals, Phosphate Fertilizer & Phosphoric Acid
Rayon	Steel Pickling	Metal Processing	Polymers like VCM
Paper & Pulp	Dyes & Intermediates	Incineration	Batteries & Gelatin

# Graphite Heat Exchangers

Graphite heat exchangers are available in 2 types -  
Block heat exchangers and Shell & Tube heat exchangers

## BLOCK HEAT EXCHANGERS

- Construction can be Monoblock, Cylindrical Polyblock, Cubical Polyblock
- Suitable material of construction can be offered for corrosive service on process and service sides
- Multi-pass arrangement enabling optimized design solution
- Process side hole diameter ranging from 8 mm up to 35 mm

Material:

- Impervious Graphite block and Graphite lateral chambers for process fluid
- Metallic Shell or Lateral chambers for service fluid. (Suitable Fluoropolymer or rubber lining can be provided if required)
- End chambers can be offered in Graphite and in different materials like Plastic, Fluoropolymer or Rubber lined carbon steel.

## Monoblock Heat Exchanger

- Compact design resulting in less space requirement
- Simple construction resulting in ease in maintenance
- General design pressure rating : 6 bar G / Full vacuum

Applications as coolers, condensers and interchangers





## Cylindrical Polyblock Heat Exchanger



- Surface area can be offered from 0.1 m<sup>2</sup> up to more than 1000 m<sup>2</sup>
- Maximum surface area per block – 73 m<sup>2</sup>
- Application and Pressure rating wise around 170 block models to provide optimised solutions
- General design pressure rating up to 12 bar G / Full vacuum on process and service sides depending on block model.

Applications as coolers, heaters, condensers, heat interchangers, isothermal falling film absorbers, reboilers, evaporators

## Cubical Polyblock Heat Exchanger



- Application and Pressure rating wise around 20 block models to provide optimised solutions
- Easy maintenance
- General design pressure rating up to 11 bar G / Full vacuum on process and service sides depending on block model.

Applications as coolers, condensers, heat interchangers, isothermal falling film absorbers

## SHELL & TUBE HEAT EXCHANGERS

- Tube sizes available – 7/8" ID x 1 ¼" OD  
1" ID x 1 ½" OD  
1 ½" ID x 2" OD
- Surface area can be offered from 1.5 m<sup>2</sup> up to 1500 m<sup>2</sup>
- General Design pressure rating: 9 Bar G / Full vacuum on process and 8 Bar G / Full vacuum on service side depending on requirement. Higher pressure rating can be offered if requested.
- Tubes with carbon fibre reinforcement for improved strength
- Tube sheets with chromium oxide coating to resist erosion due to solid content in Phosphoric acid evaporators
- Impervious Graphite tubes, tube-sheets
- Metallic or Impregnated graphite baffles
- Domes in Impervious graphite or exotic materials (suitable Fluoropolymer or rubber lined carbon steel can be offered if required)
- Metallic shell (suitable Fluoropolymer or rubber lining can be offered if required)

Applications as coolers, heaters, condensers, heat interchangers, isothermal falling film absorbers, reboilers, evaporators, quenchers



## Graphite Column

- Columns are available in Tray type or Packed type or Combination of both
- Tray types – bubble cap, turbo grid, sieve type
- Packed columns with variety of suitable internals (Ceramic Intalox Saddles, graphite raschig rings)
- Column internal diameter ranging from 100 mm ID to 2400 mm ID
- General design pressure: 5 Bar G / Full vacuum

Applications in absorption and distillation

## Graphite Ejectors

- Single stage and multi stage depending on vacuum required
- Steam jet and liquid jet
- Capacity to ensure vacuum of 0.5 Torr
- The ejector system can be supplied with surface condensers or mixing condensers
- Skid mounted unit

## Graphite Pumps

- Flow rates of 1 m<sup>3</sup>/hr up to 200 m<sup>3</sup>/hr with a differential head of 40 mtr.
- Single mechanical seal and double mechanical seal (with cooling arrangement)
- All wetted parts are in Graphite

## Acid Dilution & Cooling unit

- Units are offered for dilution of Sulphuric acid and Hydrochloric acid
- Compact arrangement of mixer and cooler
- Cooler in Polyblock type or Shell and tube type
- Unit is supplied with necessary accessories

## Sulphuric Acid Concentration Unit

- Units are designed and manufactured for producing sulphuric acid of around 70% strength from dilute acid having strength as low as 20%.
- Unit can be single stage or multi stage depending on inlet acid concentration
- Unit consists of thermosiphon reboilers, gas liquid separators, condensers, ejector system, product acid cooler.
- With multiple effect concentration, steam economy can be achieved thereby reducing operating cost.

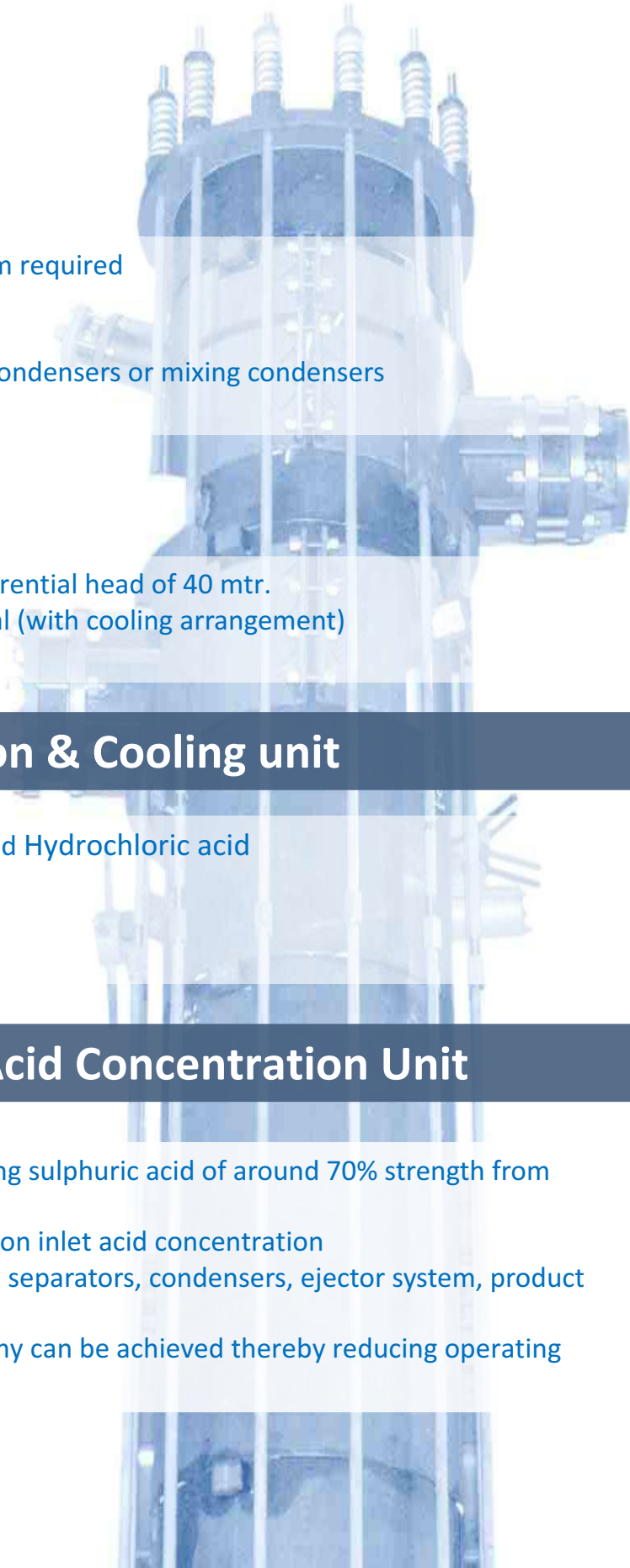



# HCl Synthesis Unit

- Top fired unit to produce commercial grade 30% to 37% Hydrochloric acid with minimum free chlorine content OR Dry HCl gas in Chlor alkali, Paper & pulp, Metal extraction industry.
- Complete skid mounted system consisting of equipment, ancillary equipment, interconnecting piping, instrumentation and necessary automation
- Capacity ranging from 1 TPD up to 200 TPD (100% HCL basis)

- Efficient burner design to ensure smooth functioning with Chlorine purity as low as 21%
- Suitable for moist feed conditions
- HCl in vent < 5 ppmv
- Heat recovery in the form of Steam generation
- Online cleaning / washing facility of burner
- Automatic start-up
- Start -up with compressed air
- Turn-down capacity of 25%
- Supplied more than 100 HCl Synthesis units worldwide

## Material:

- Combustion chamber (furnace), falling film absorber & **Burner too** in – Impervious Graphite (Steel jacketed)
- Tail Gas Tower – Impervious Graphite



Skid mounted unit

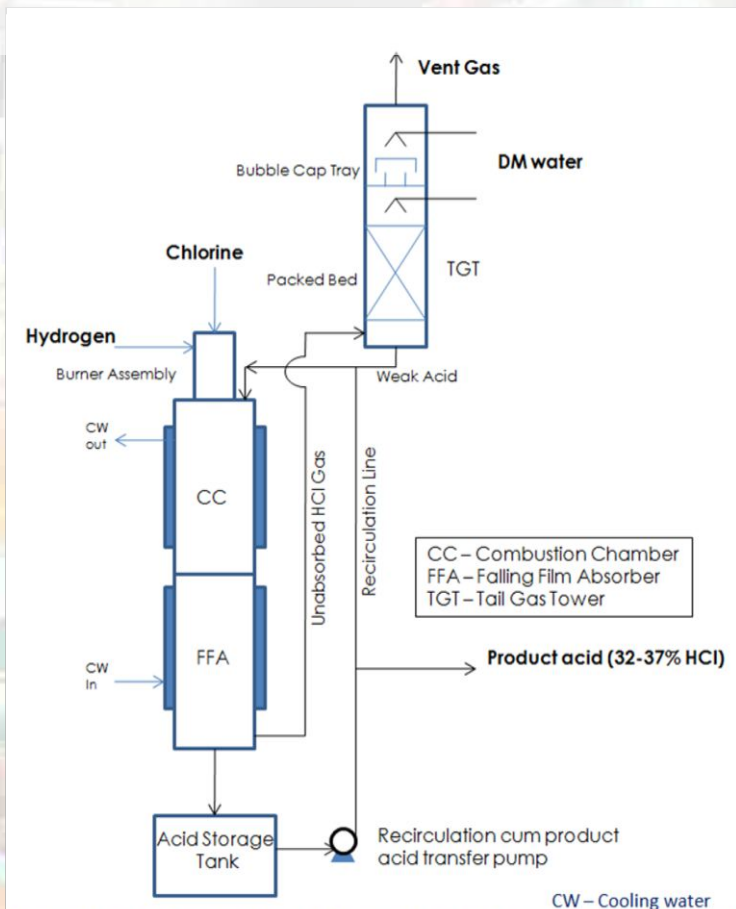



# HCl Absorption Unit

- Absorption of HCl / HF / HBr gases required in Monochloro benzene / Sulphate of Potash production / MDI-TDI/ CPW etc
- Falling film absorbers in Shell & tube and Polyblock construction
- Product Hydrochloric acid concentration ranging from 5% to 37%
- Absorbers can be designed to handle dilute gas (for less than 2% to 3%)
- Absorption can be continuous as well as in batch operation
- Complete skid mounted system consisting of Falling film absorber, Tail gas tower (Packed bed scrubber), Intermediate tank, Recirculation cum product transfer pump, interconnecting piping, instrumentation and necessary automation

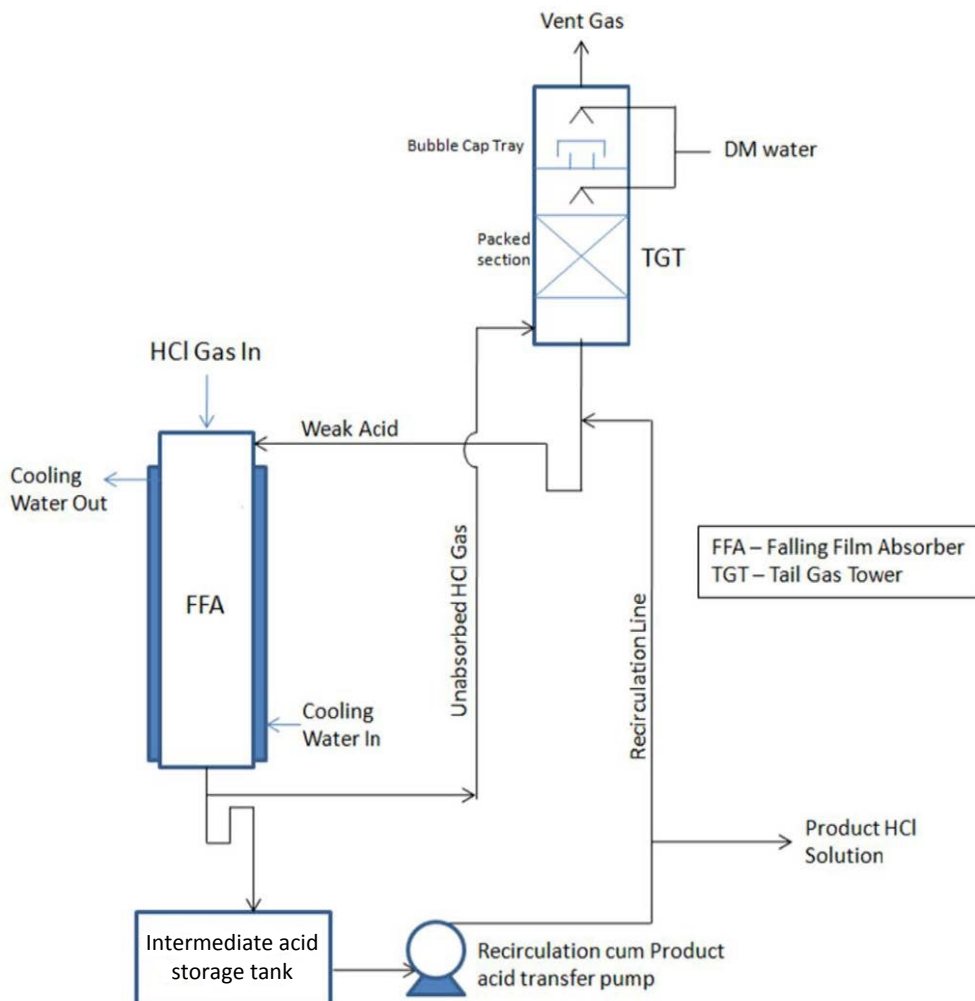

# Dry HCl Gas Generation Unit

- Commercial grade 30% to 38% Hydrochloric acid is used to produce dry HCl gas via 2 routes based on byproduct: **22% HCl Azeotropic Solution Byproduct** or **1% HCl solution Byproduct** required in API, chloro-sulphonic acid & speciality chemicals
- Dry HCl gas purity is more than 99.9%
- Capacity ranging from 25 Kg/hr to 5000 Kg/hr of HCl gas
- Maximum operating pressure of HCl gas produced by 22% HCl solution byproduct route is 3 bar G
- Maximum operating pressure of HCl gas produced by 1% HCl solution byproduct route is 1 bar G
- Complete skid mounted system consisting of equipment, ancillary equipment, interconnecting piping, instrumentation and necessary automation





# Services

Wide network ensuring prompt and effective services by qualified and experienced team comprising:

- Supervision of Erection and Commissioning activities
- Trouble-shooting and Technical support
- Maintenance and repairing of Graphite equipment and systems (on site or GIL workshop)
- Training programs for operating process systems
- Supply of spare parts



## OUR GLOBAL CUSTOMER BASE

### Asia

- Bangladesh
- China
- India
- Indonesia
- Iran
- Israel
- Japan
- Jordan
- Lebanon
- Malaysia
- Oman
- Philippines
- Qatar
- Saudi Arabia
- Singapore
- South Korea
- Taiwan
- Thailand
- Turkey

### Europe

- Austria
- Belgium
- Denmark
- France
- Germany
- Greece
- Hungary
- Italy
- Netherlands
- Norway
- Poland
- Portugal
- Russia
- Spain
- Sweden
- Switzerland
- UK

### America

- Argentina
- Brazil
- Paraguay
- Peru
- Uruguay
- USA

### Africa

- Egypt
- Morocco
- Senegal
- South Africa
- Tunisia

### Australia

- Australia



GIL/Catalogue w.e.f. 01/05/2018



## **Graphite India Ltd**

IMPERVIOUS GRAPHITE EQUIPMENT DIVISION

C-7, MIDC, Ambad, Nashik, Maharashtra, INDIA 422010

Tel.: 00 91 253 2302100

Fax: 00 91 253 2302300

E-mail: [mktgamd@graphiteindia.com](mailto:mktgamd@graphiteindia.com)

Visit us at: <http://www.graphiteindia.com/View/ige.aspx>

Registered Office & Head Office: 31, Chowringhee Road, Kolkata 700 016