

Hillmar

Hillmar Industries Ltd.

7371 Vantage Way
Delta, BC V4G 1C9
P:604 946-7115 F:604 946-0329
info@hillmar.com www.hillmar.com

INDUSTRIAL DBCB-FM DBCB-CSBFM-201-0800 SPECIFICATION SHEET SLS & MKTG ENGLISH

Sheet Number:

Job Number:

Form Number:
829-723-47072PT

Company / Project Reference:

Date.:

Page.:
1 OF 1

Document Package No.: Rev.:

Inventor Drawing

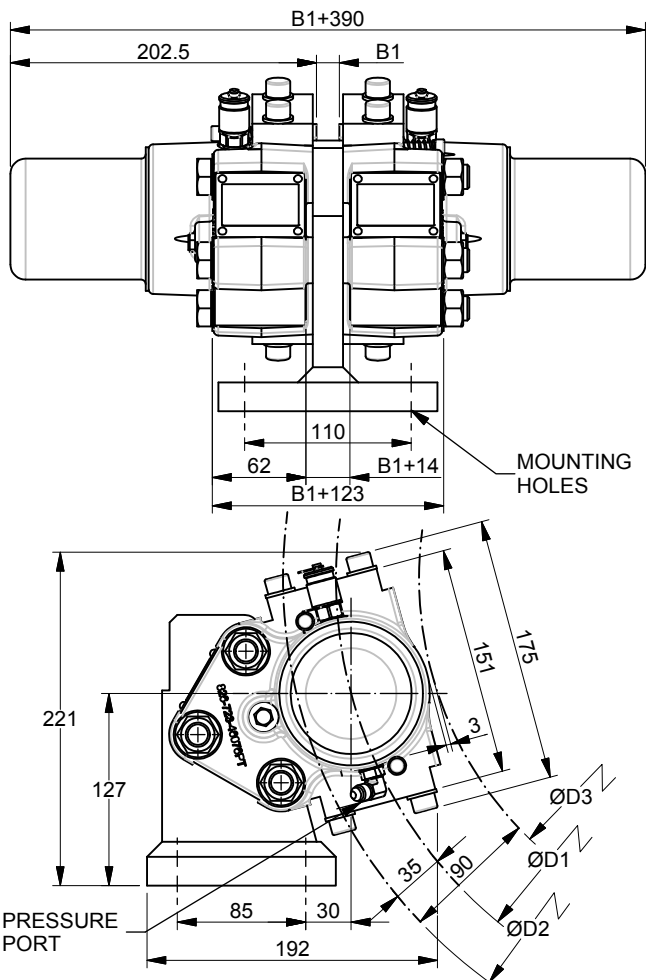
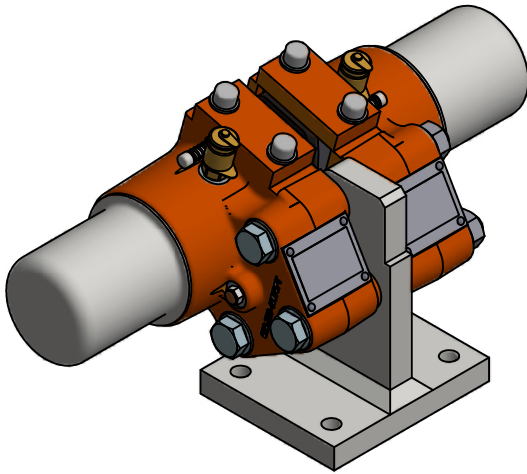

FEATURE	CODE
Industrial disc brake	DBCB
Series	CSB
Brake size	201
Foot mount	FM
Nominal braking force F_B (N)	00800

Example for ordering	DBCB-CSBFM-201-00800
-----------------------------	-----------------------------

TECHNICAL DATA

Clamping force (N) (F_c)	2000	
Braking force static $\mu=0.5$ (N) (F_c)	1000	
Braking force dynamic @ $\mu=0.4$ (N) (F_B)	800	
Loss of force pre 1mm of pad wear (%)	2.7	
Maximum wear of each brake pad (mm)	Sintered	6.5
	Organic	6.5
Disc thickness B1 (mm)	15 - 30	
Theoretical friction diameter	$\varnothing D1$	
Disc diameter	$\varnothing D2$	
Maximum coupling hub diameter	$\varnothing D3$	
Brake pad width (m)	0.06	
Nominal air gap	1 mm / side	
Braking torque (Nm) (M_B)	$M_B = F_B \times (D2 - 0.09) / 2$	
Operating pressure (bar)	19.5	
Maximum pressure (bar)	23	
Oil volume (CC) to release 1mm/half	1.34	
Pressure port connection (2 ports) T1	-4 37° JIC	
Temperature range (°C)	-20 to +70	
Standard paint PASTEL ORANGE	RAL #2003	
Mounting holes (braket)	4 x $\varnothing 13.5$	
Mounting bolts	4 x M12 CL 10.9	
Bolt tightening torque	300	
Weight of brake (2 halves) (kg)	45	

NOMINAL SPECIFICATION

Actual torque may vary depending on adjustment of brake and coefficient of friction. Brake supplied standard with organic linings.

Bearing and structure loads must be checked due to unbalanced brake loads.

NOTES

All figures are nominal figures only

All dimensions are in millimeters

Document Template #710-101-62058

** ALL TECHNICAL DATA IS SUBJECT TO CHANGE WITHOUT NOTICE **

Hillmar works have a fully registered ISO 9001-2008 quality assurance programme (QCB #01-1525)

C:\TEMP\6ba16bf1-64ec-4ab6-bc32-67de401a849b\80000526196\HILLMAR\HILLMAR PRODUCTION\08 INDUSTRIAL DBI0700-8\07008001 DBCB-CSBFM-201-00800.dwg