

Inventor Drawing

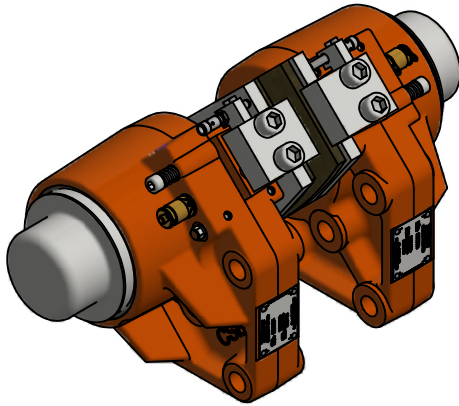

FEATURE	CODE
Industrial disc brake	DBCBS
Series	CSB
Brake size	345
Foot mount	/
Nominal braking force $F_B$ (N)	36000

<b>Example for ordering</b>	<b>DBCBS-345-36000</b>
-----------------------------	------------------------

**TECHNICAL DATA**

Clamping force (N) ( $F_C$ )	90000	
Braking force static @ $\mu=0.5$ (N) ( $F_B$ )	45000	
Braking force dynamic @ $\mu=0.4$ (N) ( $F_B$ )	36000	
Loss of force pre 1mm of pad wear (%)	4	
Maximum wear of each brake pad (mm)	Sintered	9
	Organic	9
Disc thickness B1 (mm)	20 - 40	
Theoretical friction diameter	$\varnothing D1$	
Disc diameter	$\varnothing D2$	
Maximum coupling hub diameter	$\varnothing D3$	
Brake pad width (m)	0.13	
Nominal air gap	1 mm / side	
Braking torque (Nm) ( $M_B$ )	$M_B = F_B \times (D2 - 0.13) / 2$	
Operating pressure (bar)	64	
Maximum pressure (bar)	72	
Oil volume (CC) to release 1mm/half	8.25	
Pressure port connection (2 ports) T1	1/4" BSPP	
Temperature range ( $^{\circ}C$ )	-20 to +70	
Standard paint PASTEL ORANGE	RAL #2003	
Mounting holes (brake)	4 x $\varnothing 21$	
Mounting bolts	4 x M20 CL 10.9	
Tightening torque	610	
Weight of brake (2 halves) (kg)	100	

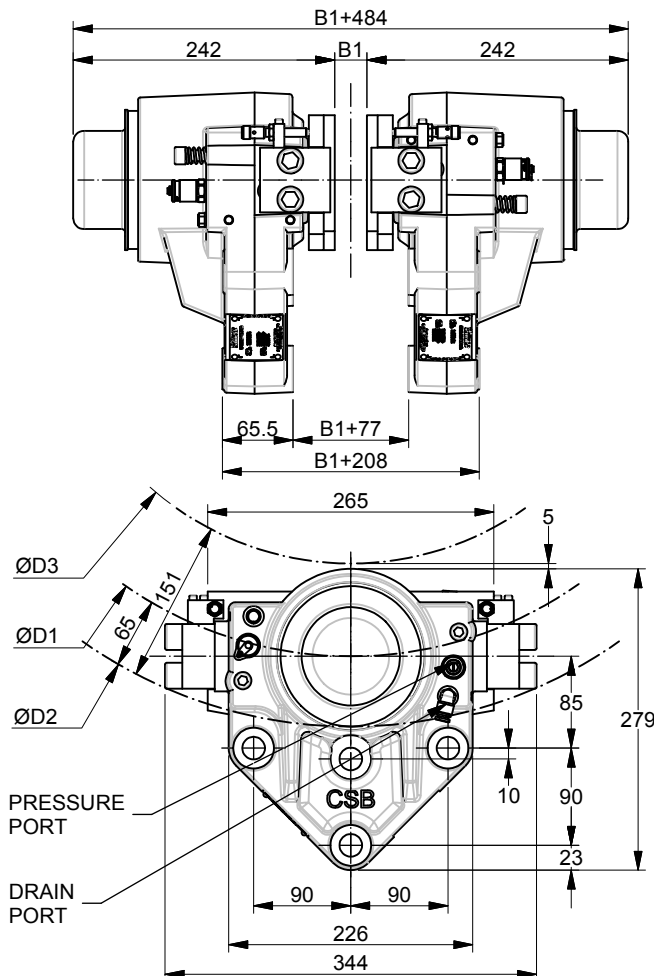

Document Template #710-101-62058

**NOMINAL SPECIFICATION**

Actual torque may vary depending on adjustment of brake and coefficient of friction. Brake supplied standard with organic linings.

Bearing and structure loads must be checked due to unbalanced brake loads.

**NOTES**

All figures are nominal figures only

All dimensions are in millimeters

\*\* ALL TECHNICAL DATA IS SUBJECT TO CHANGE WITHOUT NOTICE \*\*

Hillmar works have a fully registered ISO 9001-2008 quality assurance programme (QCB #01-1525)

C:\TEMP\6ba16fbf-e4ec-4ab6-bc32-67de401a849b\80000526102\HILLMAR\HILLMAR PRODUCTION\08 INDUSTRIAL DBI0700-807008001 DBCBS-CSB\46023 DBCBS-CSB-345-36000.idw