

Inventor Drawing

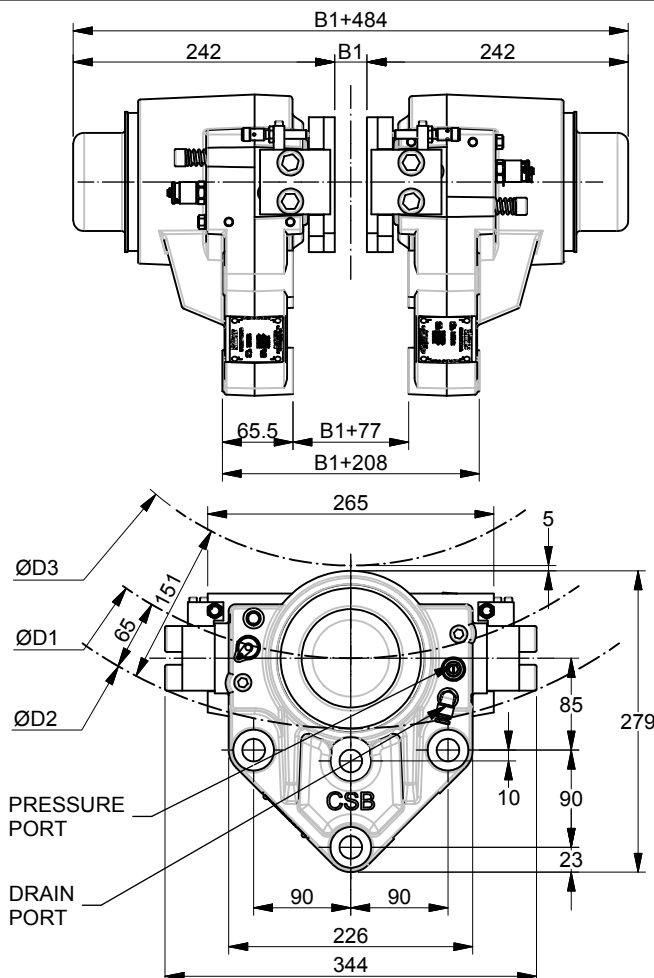
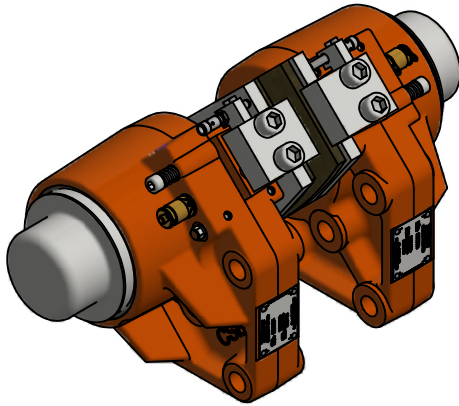

FEATURE	CODE
Industrial disc brake	DBCBS
Series	CSB
Brake size	315
Foot mount	/
Nominal braking force F_B (N)	12000

Example for ordering	DBCBS-315-12000
-----------------------------	------------------------

TECHNICAL DATA

Clamping force (N) (F_c)	30000	
Braking force static @ $\mu=0.5$ (N) (F_B)	15000	
Braking force dynamic @ $\mu=0.4$ (N) (F_B)	12000	
Loss of force pre 1mm of pad wear (%)	3.1	
Maximum wear of each brake pad (mm)	Sintered	9
	Organic	9
Disc thickness B1 (mm)	20 - 40	
Theoretical friction diameter	$\varnothing D1$	
Disc diameter	$\varnothing D2$	
Maximum coupling hub diameter	$\varnothing D3$	
Brake pad width (m)	0.13	
Nominal air gap	1 mm / side	
Braking torque (Nm) (M_B)	$M_B = F_B \times (D2 - 0.13) / 2$	
Operating pressure (bar)	22	
Maximum pressure (bar)	26	
Oil volume (CC) to release 1mm/half	8.25	
Pressure port connection (2 ports) T1	1/4" BSPP	
Temperature range (°C)	-20 to +70	
Standard paint PASTEL ORANGE	RAL #2003	
Mounting holes (brake)	4 x $\varnothing 21$	
Mounting bolts	4 x M20 CL 10.9	
Tightening torque	610	
Weight of brake (2 halves) (kg)	100	

NOMINAL SPECIFICATION

Actual torque may vary depending on adjustment of brake and coefficient of friction. Brake supplied standard with organic linings.

Bearing and structure loads must be checked due to unbalanced brake loads.

NOTES

All figures are nominal figures only

All dimensions are in millimeters

** ALL TECHNICAL DATA IS SUBJECT TO CHANGE WITHOUT NOTICE **

Hillmar works have a fully registered ISO 9001-2008 quality assurance programme (QCB #01-1525)

Document Template #710-101-62058

C:\TEMP\6bar16f64ec-4ab6-bc32-67de401a849b80000526091\HILLMAR\HILLMAR PRODUCTION\08 INDUSTRIAL DBI0700-807008001 DBCBS-315-12000.idw