

Inventor Drawing

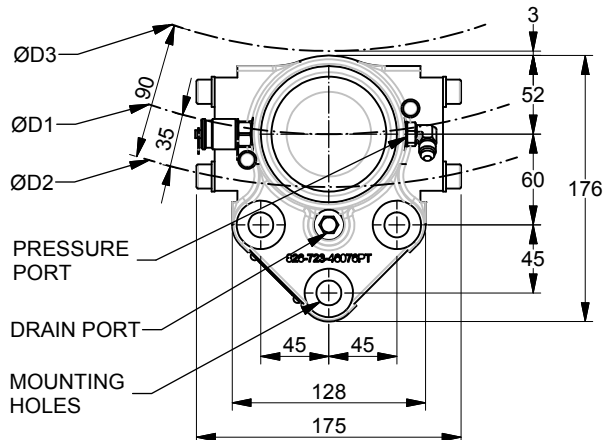
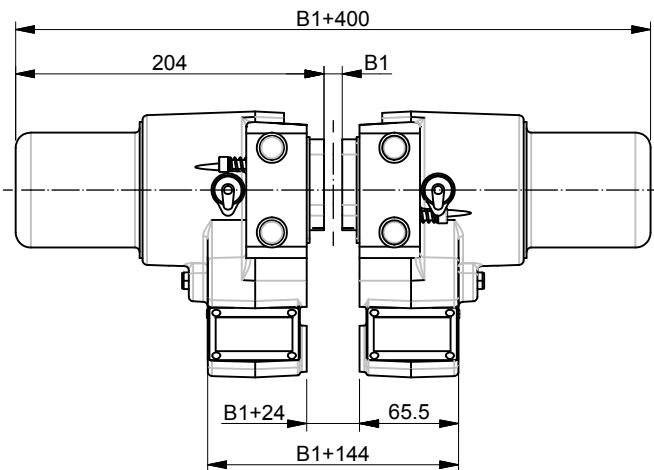
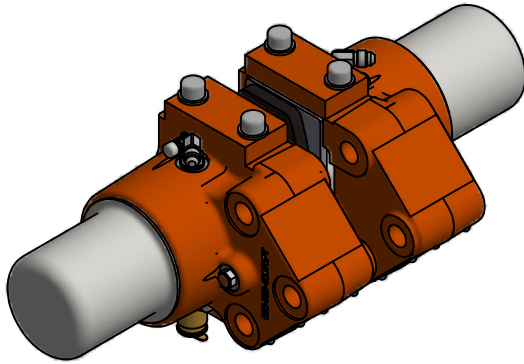

FEATURE	CODE
Industrial disc brake	DBCBS
Series	CSB
Brake size	207
Foot mount	/
Nominal braking force F_B (N)	5600

Example for ordering	DBCBS-207-5600
-----------------------------	-----------------------

TECHNICAL DATA		
Clamping force (N) (F_C)	14000	
Braking force static $\mu=0.5$ (N) (F_B)	7000	
Braking force dynamic @ $\mu=0.4$ (N) (F_B)	5600	
Loss of force pre 1mm of pad wear (%)	4.6	
Maximum wear of each brake pad (mm)	Sintered	6.5
	Organic	6.5
Disc thickness B1 (mm)	15 - 30	
Theoretical friction diameter	$\varnothing D1$	
Disc diameter	$\varnothing D2$	
Maximum coupling hub diameter	$\varnothing D3$	
Brake pad width (m)	0.06	
Nominal air gap	1 mm / side	
Braking torque (Nm) (M_B)	$M_B = F_B \times (D2 - 0.07) / 2$	
Operating pressure (bar)	71	
Maximum pressure (bar)	79	
Oil volume (CC) to release 1mm/half	1.34	
Pressure port connection (2 ports) T1	-4 37° JIC	
Temperature range (°C)	-20 to +70	
Standard paint PASTEL ORANGE	RAL #2003	
Mounting holes (brake)	3 x $\varnothing 16.5$	
Mounting bolts	3 x M16 CL 10.9	
Bolt tightening torque	300	
Weight of brake (2 halves) (kg)	40	

NOMINAL SPECIFICATION

Actual torque may vary depending on adjustment of brake and coefficient of friction. Brake supplied standard with organic linings.

Bearing and structure loads must be checked due to unbalanced brake loads.

NOTES

All figures are nominal figures only

All dimensions are in millimeters

** ALL TECHNICAL DATA IS SUBJECT TO CHANGE WITHOUT NOTICE **

Hillmar works have a fully registered ISO 9001-2008 quality assurance programme (QCB #01-1525)

Document Template #710-101-62058

C:\TEMP\6ba16fbf-64ec-4ab6-bc32-67de401a849b\80000526156\HILLMAR\HILLMAR PRODUCTION\08 INDUSTRIAL DBI\0700-807\008001 DBCBS-CSB\46117 DBCBS-CSB-207-5600.dwg