

WB SERIES

EDDY-CURRENT DYNAMOMETERS

MAGTROL offers 3 types of dynamometer brakes to absorb load: Hysteresis (**HD Series**), Eddy-Current (**WB Series**) and Magnetic Powder (**PB Series**). Each type of Dynamometer has advantages and limitations and choosing the correct one will depend largely on the type of testing to be performed. With over 50 standard models to choose from, Magtrol Sales professionals are readily available to assist in selecting the proper Dynamometer to meet your testing needs.

FEATURES

- 13 Models with Maximum Torque: 300 mN·m ... 560 N·m (42 oz·in ... 413 lb·ft)
- Braking Power: 500 W ... 140 kW
- Stable Braking Torque, without Shock
- Low Moment of Inertia
- Low Residual Torque
- Operating Direction CW/CCW
- Braking Torque Measurement Integrated
- High Rotational Speed
- Integrated Optical Speed Sensor
- Special designs available upon request



Fig. 1: 1 WB43 | Eddy-Current Dynamometer

DESCRIPTION

Eddy-Current Brake Dynamometers (WB Series) are ideal for applications requiring high speeds and also when operating in the middle to high power range. Eddy-Current Brakes provide increasing torque as the speed increases, reaching peak torque at rated speed. The dynamometers have low inertia as a result of small rotor diameter. Brake cooling is provided by a water circulation system, which passes inside the stator to dissipate heat generated by the braking, providing high continuous power ratings (max. 140 kW). WB Series Dynamometers integrate a torque measuring system with an accuracy ratings of $\pm 0.3\%$ to $\pm 0.5\%$ full scale, depending on size and system configuration.

OPERATING PRINCIPLES

The WB Eddy-Current Dynamometers develop their full power at high rotation speeds. The WB Series is particularly intended for motors which rotate at high speeds, up to 65 000 rpm (up to 100 000 rpm with WB 23/27; see specific datasheet). The braking torque depends on the rotation speed.

APPLICATIONS

Mounted on test benches, the WB Series Eddy-Current Dynamometers allow performance and reliability testing on driving elements such as servomotors, micromotors for cameras, fans, drills, combustion engine, pumps, pneumatic equipment, hydraulic transmission systems, gas turbines, spindles, compressors and motors for domestic appliances.

OPTICAL SPEED SENSOR

Each WB Series Dynamometer is equipped with an optical speed sensor delivered as standard. WB 2.7, WB 43 and WB 65 HS are equipped with a 30 PPR (Pulses Per Revolution) optical encoder; WB 65, WB 115 & WB 15 are equipped with a 60 PPR optical encoder.

MODELS	WB 2.7	WB 43	WB 43 HS	WB 65	WB 65 HS	WB 115	WB 115 HS	WB 15	WB 15 HS
Encoder 30 PPR	x	x	x		x				
Encoder 60 PPR				x		x	x	x	x

DYNAMOMETER CONFIGURATIONS

The Dynamometers can be complemented by various electronic modules such as the DES Series (Power Supply), TSC401 (Torque/Speed Conditioner) and DSP7000 (High Speed Programmable Dynamometer Controller).

Magtrol also offers In-Line Torque Transducers (TS Series or TM Series) or Torque Flange (TF Series) for extremely

accurate torque and speed measurement with high noise immunity. For a dynamic, high-precision system, the torque transducer can be mounted in line between the unit under test and the dynamometer, providing a torque accuracy of 0.1%.

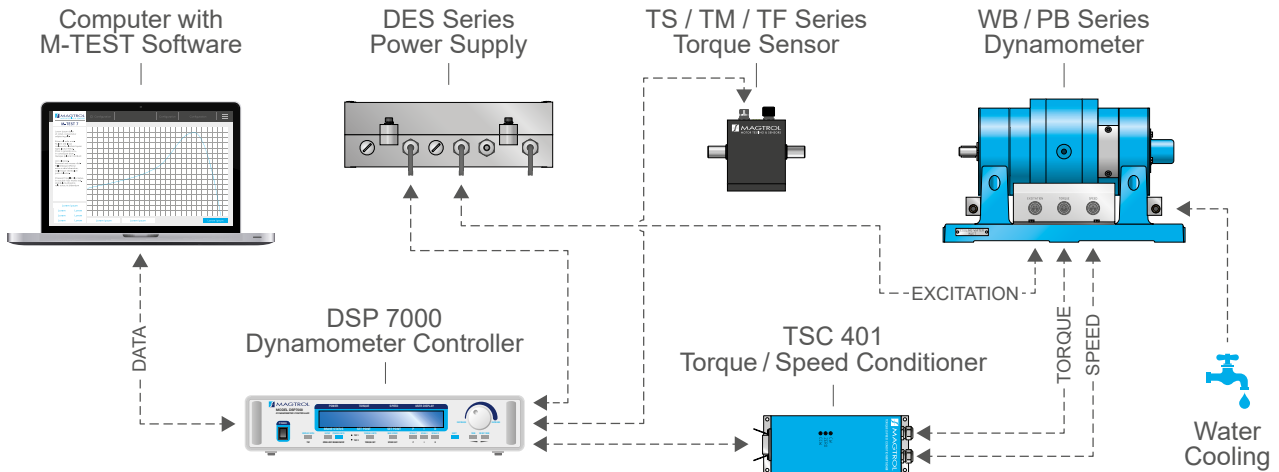

Fig. 2: Configuration of the WB Series Dynamometer with its accessories

SPECIFICATIONS

NOTE: For continuous operating (≥ 2 hours) at constant torque or power, please consider 20% reserve in both torque & power

MODEL	RATED TORQUE		DRAG TORQUE DE-ENERGIZED		NOMINAL INPUT INERTIA		RATED POWER	RATED SPEED	MAX. SPEED		EXCITATION CURRENT
	N·m	oz·in	mN·m	oz·in	kg·m ²	lb·ft·s ²			STANDARD	HIGH-SPEED (HS version)	
2WB2.7	0.3	42.4	9	1.27	2.33x10 ⁻⁵	1.71x10 ⁻⁵	0.5	15915	50000	N/A	1.0 ^{a)}
3WB2.7	0.45	63.7			3.18x10 ⁻⁵	2.34x10 ⁻⁵	0.75				1.5 ^{a)}
4WB2.7	0.6	84.9			4.03x10 ⁻⁵	2.97x10 ⁻⁵	1.0				2.0 ^{a)}
1WB43	1.5	211.2	15	2.12	1.21x10 ⁻⁴	8.92x10 ⁻⁵	1.5	9550	50000	65000	1.0 ^{b)}
2WB43	3.0	422.4	30	4.24	2.17x10 ⁻⁴	1.60x10 ⁻⁴	3.0				2.0 ^{b)}
MODEL	RATED TORQUE		DRAG TORQUE DE-ENERGIZED		NOMINAL INPUT INERTIA		RATED POWER	RATED SPEED	MAX. SPEED		EXCITATION CURRENT
	N·m	lb·ft	N·m	lb·in	kg·m ²	lb·ft·s ²			STANDARD	HIGH-SPEED (HS version)	
1WB65	10	7.3	0.1	0.88	0.82x10 ⁻³	6.04x10 ⁻⁴	6	5730	30000	50000	2.5 ^{c)}
2WB65	20	14.7	0.2	1.77	1.55x10 ⁻³	1.14x10 ⁻³	12				5.0 ^{c)}
1WB115	50	36.8	0.5	4.43	1.27x10 ⁻²	9.36x10 ⁻³	15	2865	18000	22000	2.5 ^{c)}
2WB115	100	73.7	1.0	8.85	2.57x10 ⁻²	1.89x10 ⁻²	30				5.0 ^{c)}
1WB15	140	103.0	1.4	12.30	5.00x10 ⁻²	3.68x10 ⁻²	35	2390	7500	10000	4.0 ^{d)}
2WB15	280	206.0	2.8	24.70	1.00x10 ⁻¹	7.37x10 ⁻²	70				7.5 ^{d)}
3WB15	420	309.0	4.2	37.10	1.50x10 ⁻¹	1.10x10 ⁻¹	105				10.0 ^{d)}
4WB15	560	413.0	5.6	49.50	2.00x10 ⁻¹	1.47x10 ⁻¹	140				12.0 ^{d)}

a) Voltage at 20°C is 15V
b) Voltage at 20°C is 24V

c) Voltage at 20°C is 30V
d) Voltage at 20°C is 45V

WB 2.7 TORQUE-SPEED-POWER CURVES

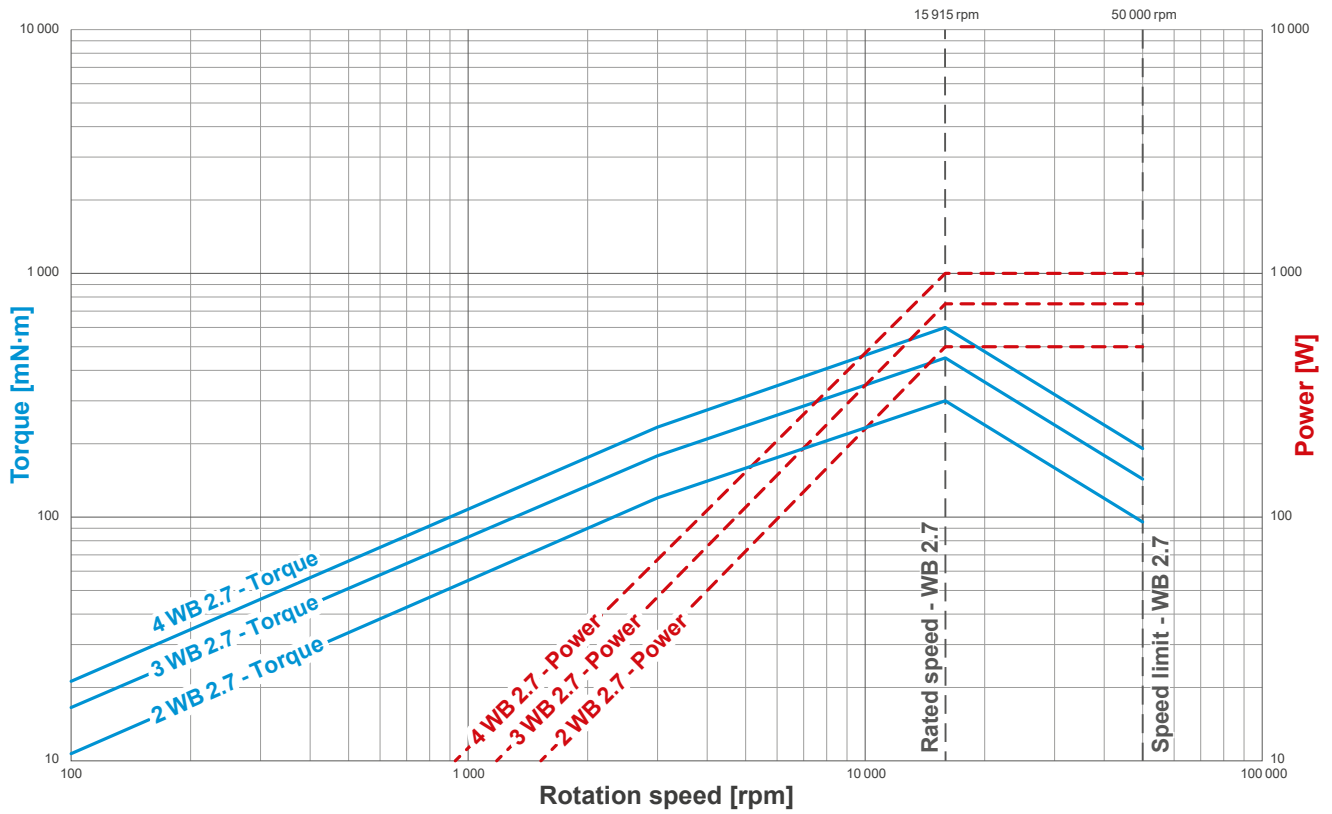

WB 43 TORQUE-SPEED-POWER CURVES

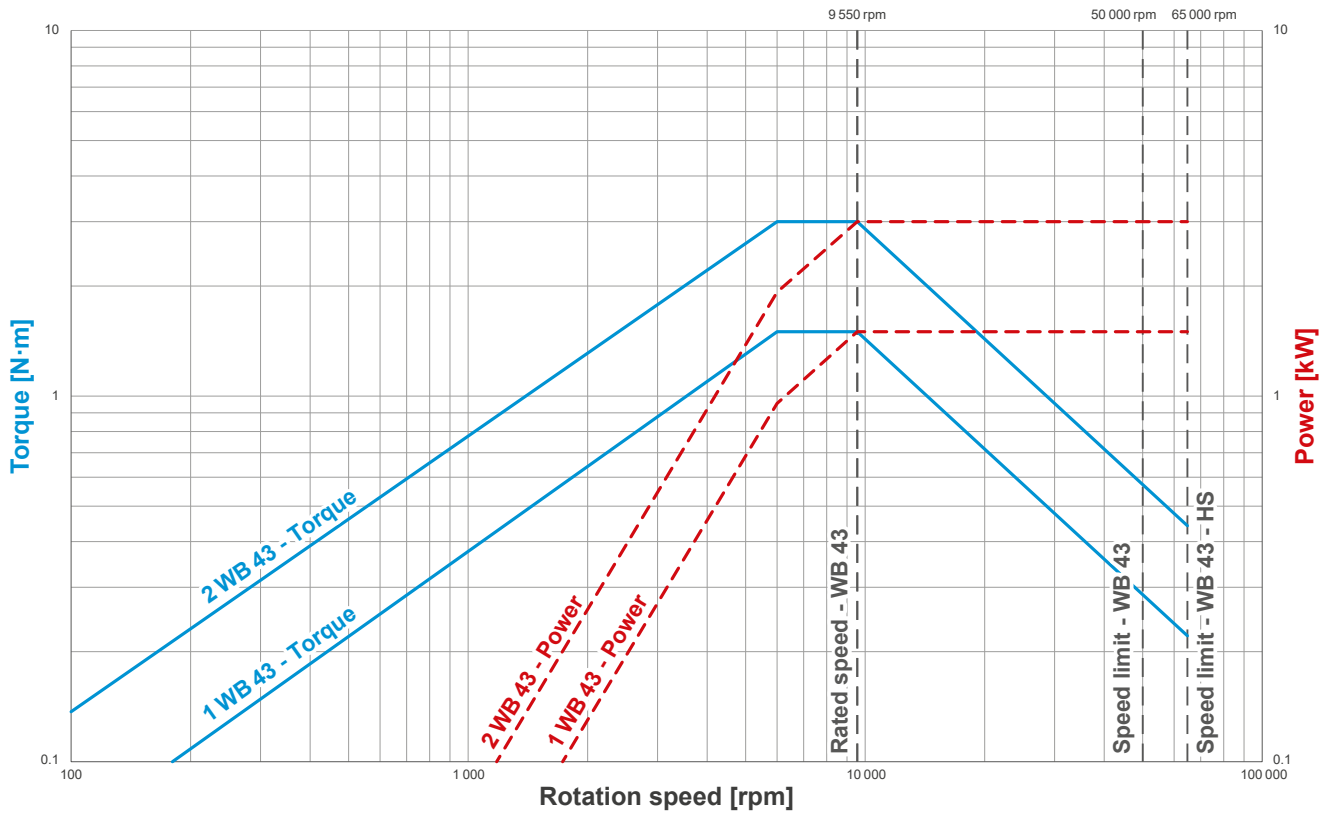

WB 65 & WB 115 TORQUE-SPEED-POWER CURVES

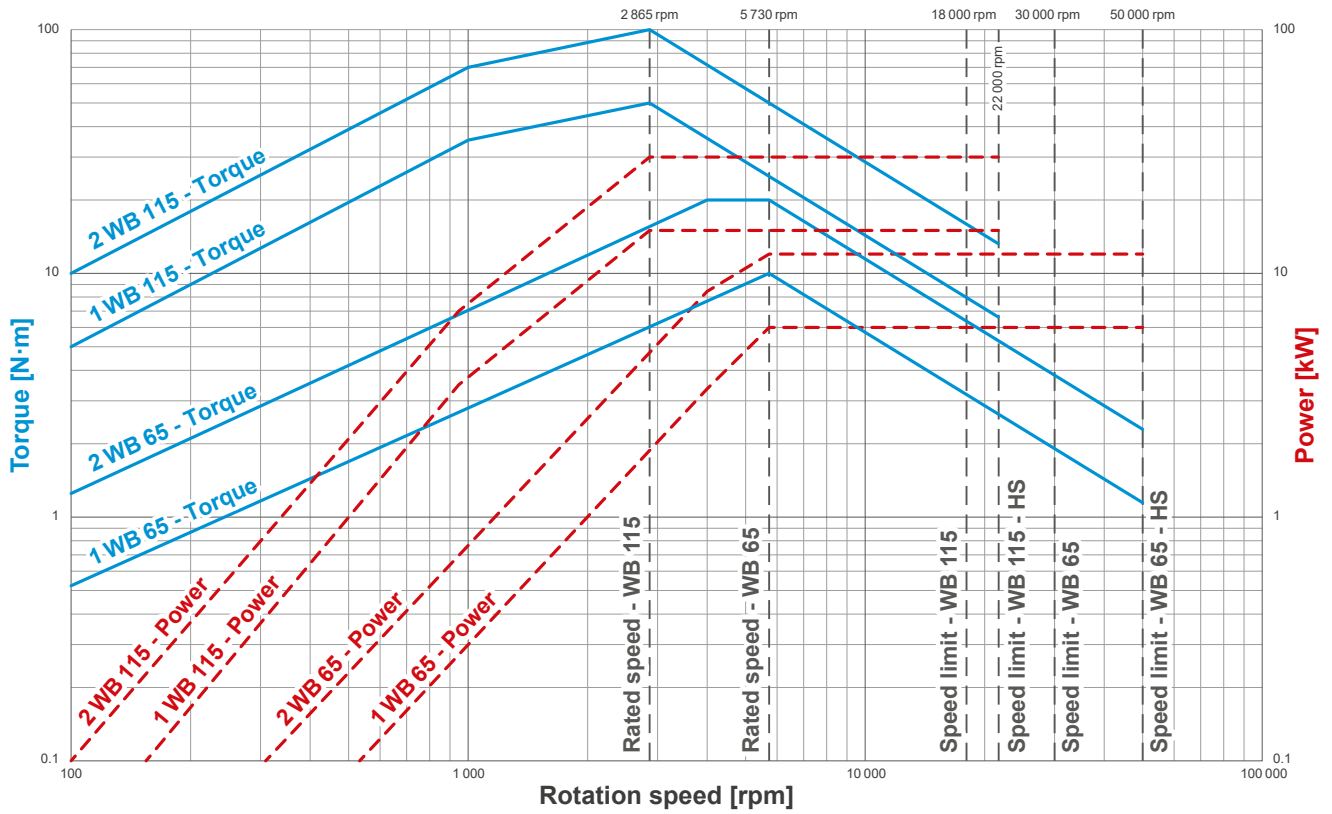

WB 15 TORQUE-SPEED-POWER CURVES

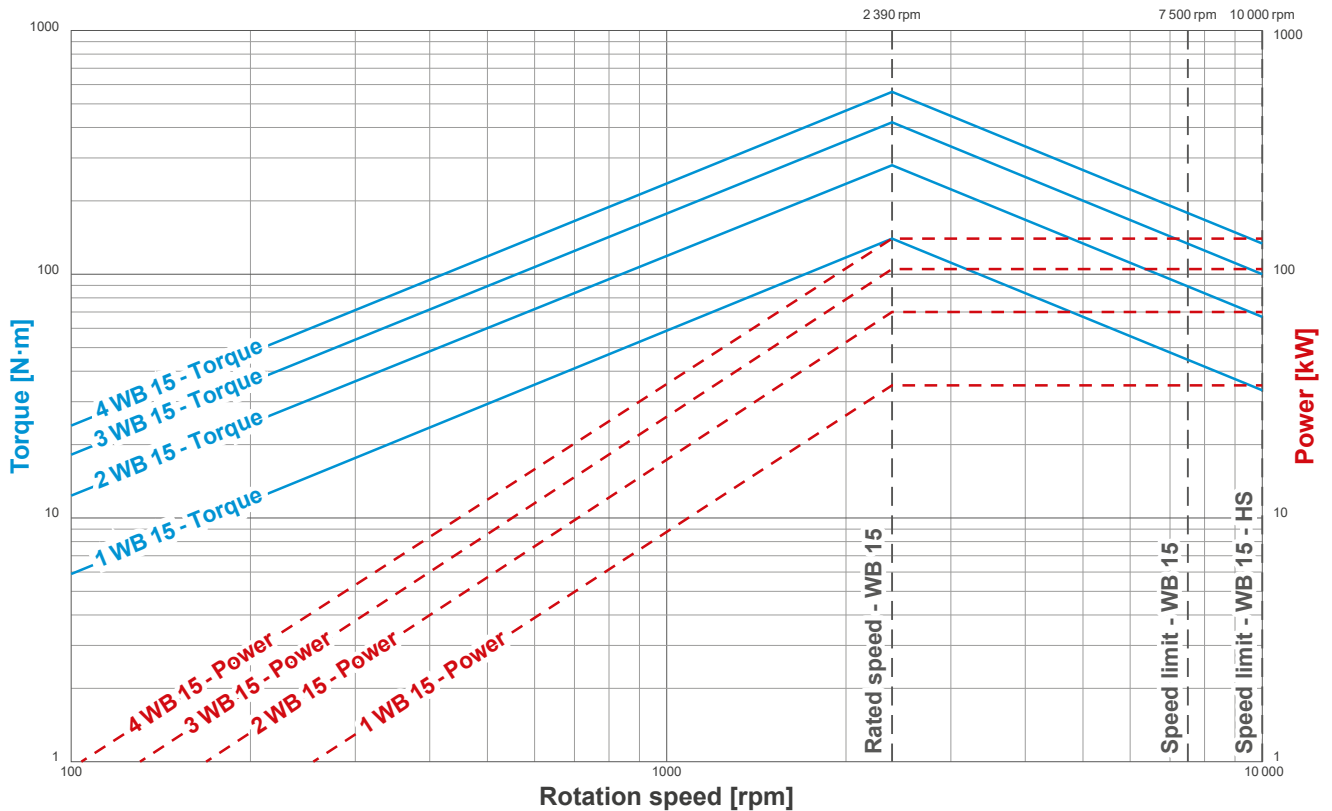

WB 2.7 DIMENSIONS

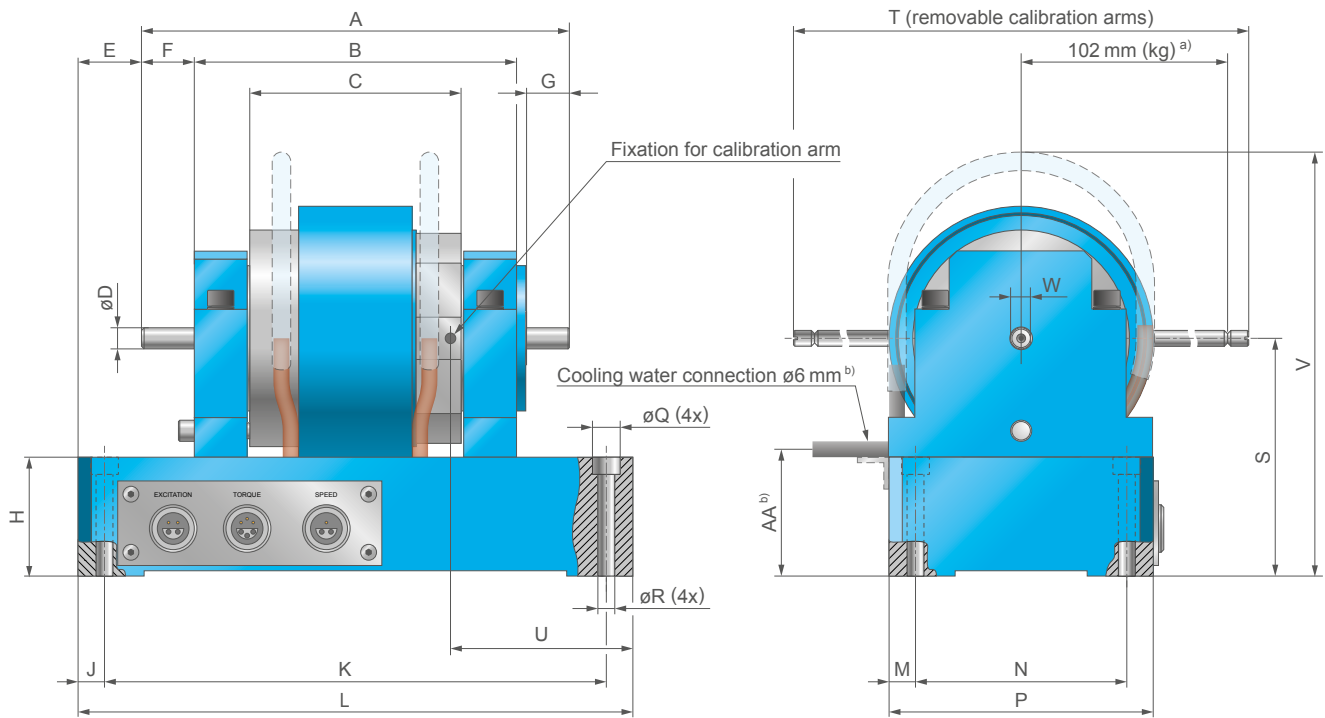

CAUTION: All WB Series Dynamometers must be water cooled.

NOTE: Original dimensions are in metric units. Dimensions converted to English units have been rounded up to 4 decimal places.

MODEL	units	A	B	C	øD	E	F	G	H	J	K	L	M	N
2WB2.7	mm	162	122	80	8h5	24	20	16	45	10	190	210	10	80
	in	6.38	4.8	3.15	0.3148 0.3149	0.94	0.79	0.63	1.77	0.39	7.48	8.27	0.39	3.15
3WB2.7	mm	186	146	104	8h5	12	20	16	45	10	190	210	10	80
	in	7.32	5.75	4.09	0.3148 0.3149	0.47	0.79	0.63	1.77	0.39	7.48	8.27	0.39	3.15
4WB2.7	mm	210	170	128	8h5	-	20	16	45	10	190	210	10	80
	in	8.27	6.69	5.04	0.3148 0.3149	-	0.79	0.63	1.77	0.39	7.48	8.27	0.39	3.15

MODEL	units	P	øQ	øR	S	T	U	V	W	AA	Weight
2WB2.7	mm	100	10.5	6.4	90±0.1	220	69	152	7.6	48	~ 5.3kg
	in	3.94	0.413	0.252	0.547 0.539	8.66	2.72	5.98	0.299	1.89	~ 11.7lb
3WB2.7	mm	100	10.5	6.4	90±0.1	220	57	152	7.6	48	~ 6.4 kg
	in	3.94	0.413	0.252	0.547 0.539	8.66	2.24	5.98	0.299	1.89	~ 14.2lb
4WB2.7	mm	100	10.5	6.4	90±0.1	220	45	152	7.6	48	~ 7.5kg
	in	3.94	0.413	0.252	0.547 0.539	8.66	1.77	5.98	0.299	1.89	~ 16.6lb

a) For calibration in N·m with weight in kg

NOTE: 3D STEP files for most of our products are available on our website: www.magtrol.com. Other files are available on request.

WB 43 DIMENSIONS

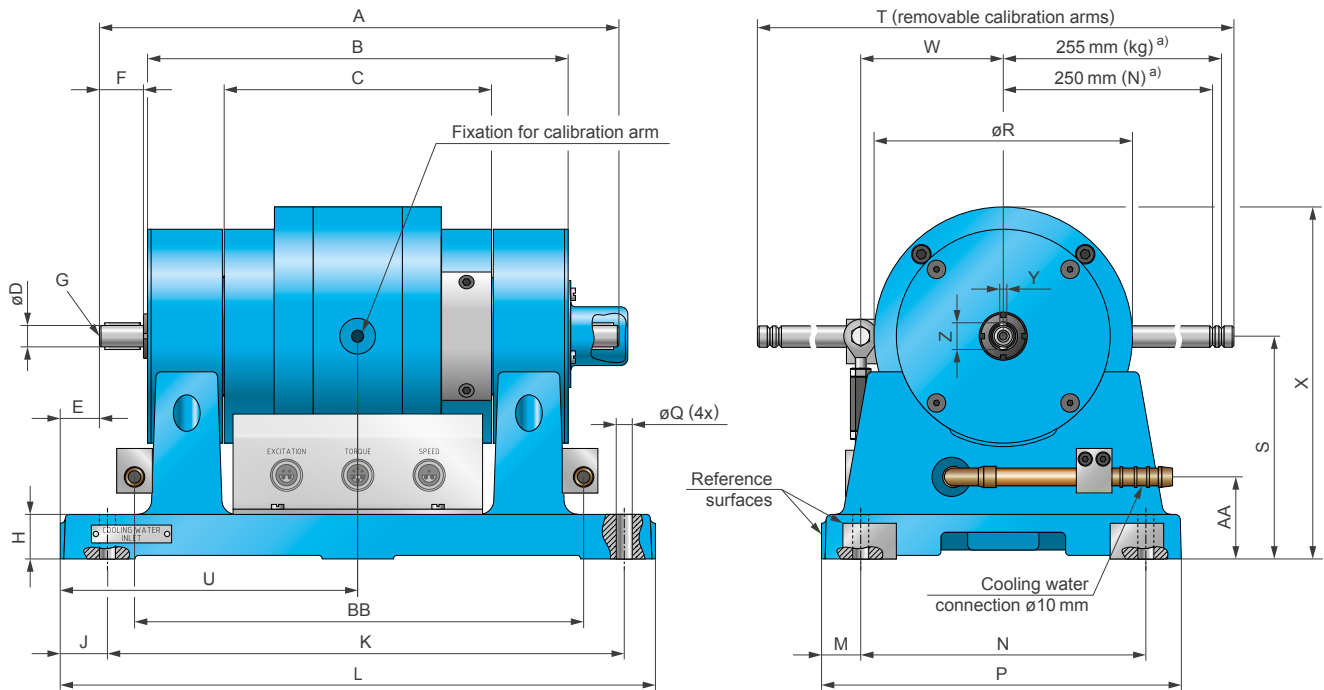

CAUTION: All WB Series Dynamometers must be water cooled.

NOTE: Dimensions for the specific versions (HS, IS, ... see page 10) can slightly vary from the standard versions.

For more information, please, contact our sales technicians for specific drawing.

NOTE: Original dimensions are in Metric units. Dimensions converted to English units have been rounded up to 4 decimal places.

MODEL	units	A	B	C	øD ^{c)}	E	F	G ^{b)}	H	J	K	L	M	N	P
1WB43	mm	240	186	100	12h6	22	25	M4	25	22	240	284	22	160	202
	in	9.45	7.32	3.94	0.4724 0.4721	0.87	0.98		0.98	0.87	9.45	11.18	0.87	6.30	7.95
2WB43	mm	290	236	150	12h6	22	25		25	22	290	334	22	160	202
	in	11.42	9.29	5.91	0.4724 0.4721	0.87	0.98		0.98	0.87	11.42	13.15	0.87	6.30	7.95

MODEL	units	øQ	øR	S	T	U	W	X	Y	Z	AA	BB	Weight
1WB43	mm	9	145	125±0.05	524	153	80	198	4 h9	15	46	202	~ 24 kg
	in	0.35	5.71	4.923 4.919	20.63	6.02	3.15	7.80	0.1574 0.1563	0.59	1.81	7.95	~ 52.9 lb
2WB43	mm	9	145	125±0.05	524	167	80	198	4 h9	15	46	252	~ 31 kg
	in	0.35	5.71	4.923 4.919	20.63	6.57	3.15	7.80	0.1574 0.1563	0.59	1.81	9.92	~ 68.4 lb

a) 255 mm for a calibration in N·m with weight in kg (use outer groove);
250 mm for calibration in N·m with weight in N (use inner groove)

b) Center according to DIN 332-D

c) Shaft of High Speed version (HS) is ø12h6, smooth (without key) with a different length. For more information, please contact our sale service.

NOTE: 3D STEP files for most of our products are available on our website: www.magtrol.com. Other files are available on request.

WB 65 DIMENSIONS

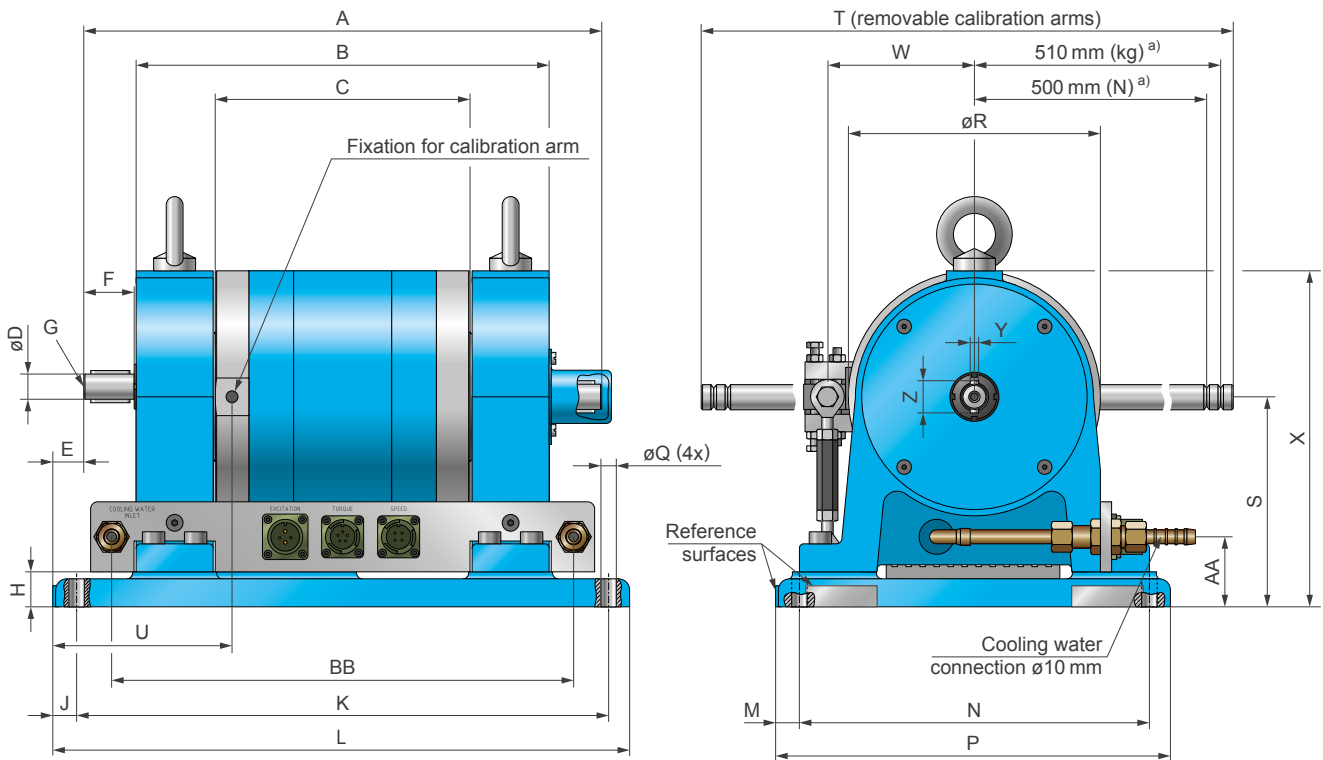

CAUTION: All WB Series Dynamometers must be water cooled.

NOTE: Dimensions for the specific versions (HS, IS, ... see page 10) can slightly vary from the standard versions.

For more information, please, contact our sales technicians for specific drawing.

NOTE: Original dimensions are in metric units. Dimensions converted to English units have been rounded up to 4 decimal places.

MODEL	units	A	B	C	øD ^{c)}	E	F	G ^{b)}	H	J	K	L	M	N	P
1 WB 65	mm	300	225	112	18h6	22	36	M5	25	17	310	342	17	250	282
	in	11.81	8.86	4.41	0.7086 0.7083	0.87	1.42		0.98	0.67	12.2	13.46	0.67	9.84	11.10
2 WB 65	mm	370	295	182	18h6	22	36		25	17	380	412	17	250	282
	in	14.57	11.61	7.17	0.7086 0.7083	0.87	1.42		0.98	0.67	14.96	16.22	0.67	9.84	11.10

MODEL	units	øQ	øR	S	T	U	W	X	Y	Z	AA	BB	Weight
1 WB 65	mm	11	180	150±0.1	1034	128	105	240	6h9	23	50	260	~ 55kg
	in	0.43	7.09	5.909 5.902	40.71	5.04	4.13	9.45	0.2362 0.2351	0.91	1.97	10.24	~ 122lb
2 WB 65	mm	11	180	150±0.1	1034	128	105	240	6h9	23	50	330	~ 70kg
	in	0.43	7.09	5.909 5.902	40.71	5.04	4.13	9.45	0.2362 0.2351	0.91	1.97	12.99	~ 155lb

a) 510mm for a calibration in N·m with weight in kg (use outer groove);
500mm for a calibration in N·m with weight in N (use inner groove).

b) Center according to DIN 332-D

c) Shaft of High Speed version (HS) is ø12h6, smooth (without key) with a different length. For more information, please contact our sale service.

NOTE: 3D STEP files for most of our products are available on our website: www.magtrol.com. Other files are available on request.

WB 115 DIMENSIONS

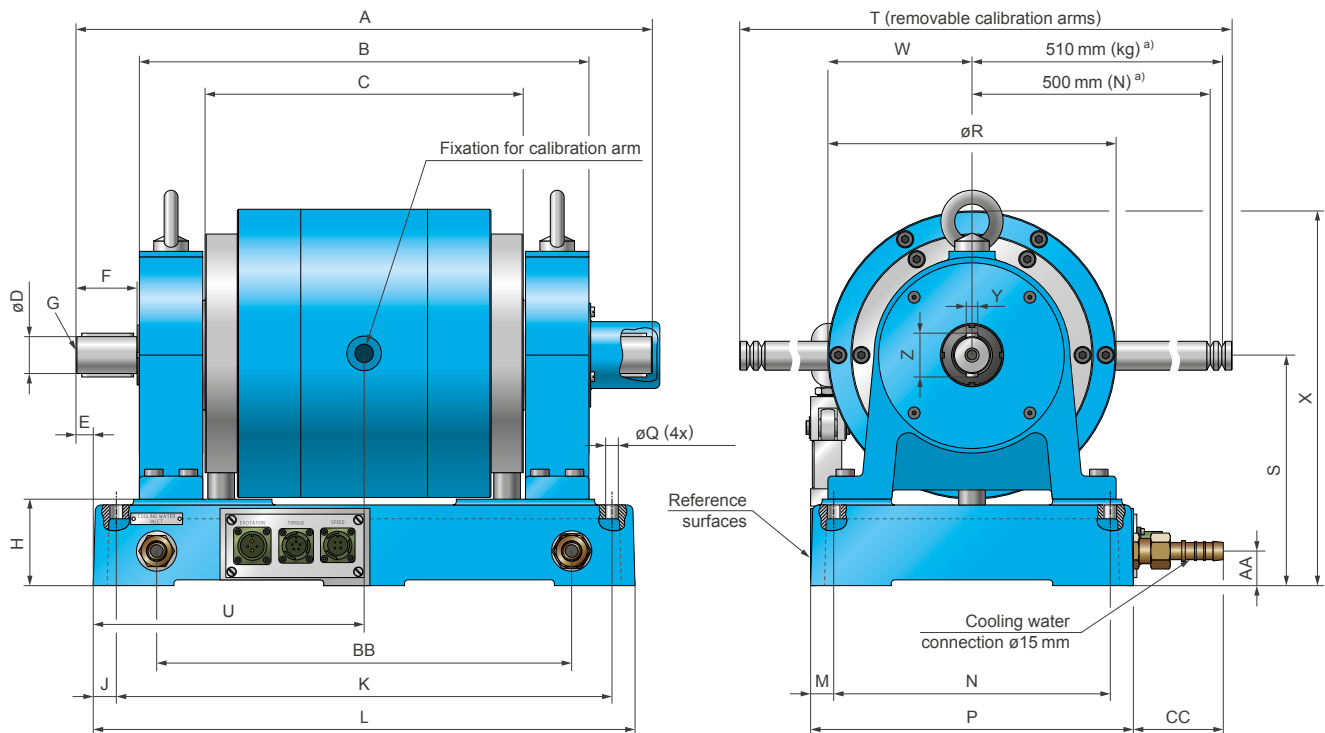

CAUTION: All WB Series Dynamometers must be water cooled.

NOTE: Dimensions for the specific versions (HS, IS, ... see page 10) can slightly vary from the standard versions.

For more information, please, contact our sales technicians for specific drawing.

NOTE: Original dimensions are in metric units. Dimensions converted to imperial units have been rounded up to 4 decimal places.

MODEL	units	A	B	C	øD	E	F	G ^{b)}	H	J	K	L	M	N	P
1WB 115	mm	390	280	166	32h6	-40	54	M8	75	20	430	470	40	200	280
	in	15.35	11.02	6.54	1.2598 1.2593	-1.57	2.13		2.95	0.79	16.93	18.50	1.57	7.87	11.02
2WB 115	mm	500	390	276	32h6	15	54		75	20	430	470	40	200	280
	in	19.69	15.35	10.87	1.2598 1.2593	0.59	2.13		2.95	0.79	16.93	18.50	1.57	7.87	11.02

MODEL	units	øQ	øR	S	T	U	W	X	Y	Z	AA	BB	CC	Weight
1WB 115	mm	11	250	200±0.1	1038	197	125	325	10h9	38	30	360	80	~ 80 kg
	in	0.43	9.84	7.878 7.870	40.87	7.76	4.92	12.80	0.3937 0.3932	1.50	1.18	14.17	3.15	~ 177 lb
2WB 115	mm	11	250	200±0.1	1038	235	125	325	10h9	38	30	360	80	~ 130 kg
	in	0.43	9.84	7.878 7.870	40.87	9.25	4.92	12.80	0.3937 0.3932	1.50	1.18	14.17	3.15	~ 287 lb

a) 510mm for a calibration in N·m with weight in kg (use outer groove);
500mm for a calibration in N·m with weight in N (use inner groove).

b) Center according to DIN 332-D

NOTE: 3D STEP files for most of our products are available on our website: www.magtrol.com. Other files are available on request.

WB 15 DIMENSIONS

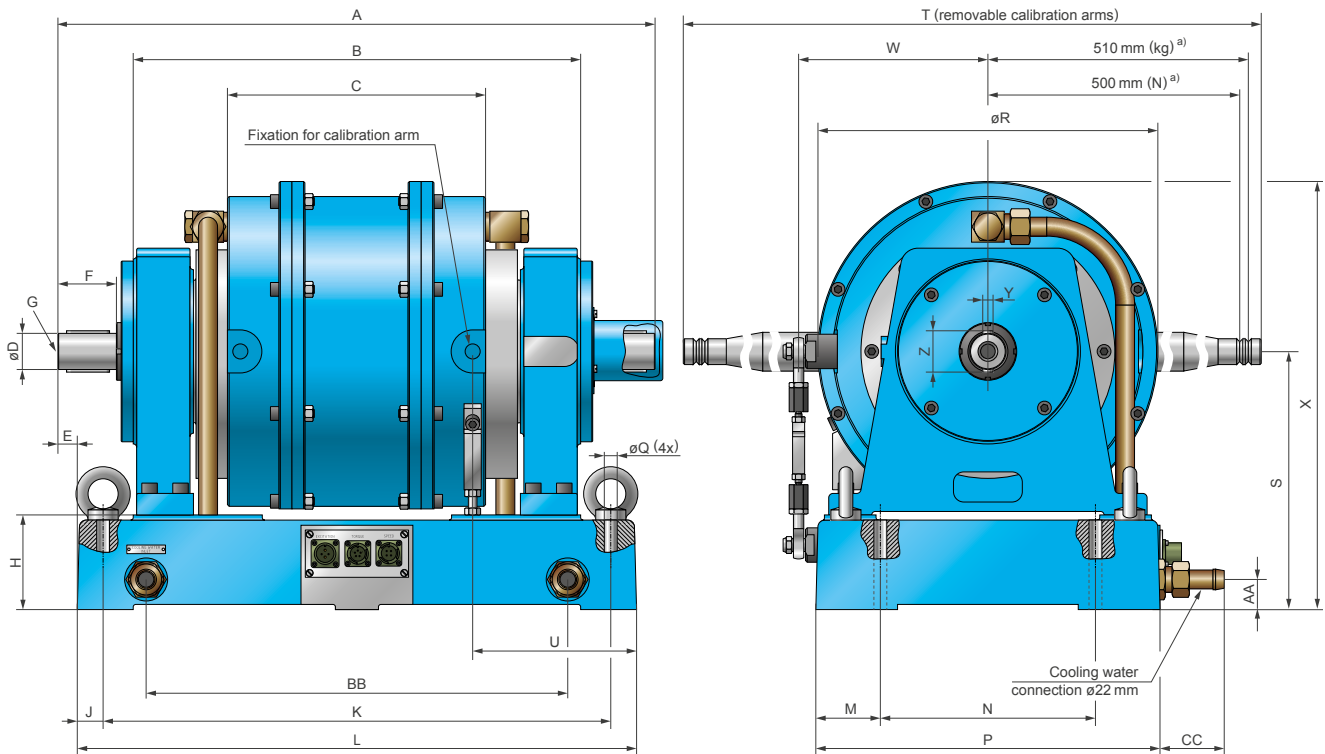

CAUTION: All WB Series Dynamometers must be water cooled.

NOTE: Dimensions for the specific versions (HS, IS, ... see page 10) can slightly vary from the standard versions.

For more information, please, contact our sales technicians for specific drawing.

NOTE: Original dimensions are in metric units. Dimensions converted to imperial units have been rounded up to 4 decimal places.

MODEL	units	A	B	C	ØD	E	F	G ^{b)}	H	J	K	L	M	N	P
1 WB 15	mm	544	370	150	42g6	-53	68	M8	110	30	590	650	75	250	400
	in	21.42	14.57	5.91	1.6531 1.6526	-2.09	2.68		4.33	1.18	23.23	25.59	2.95	9.84	15.75
2 WB 15	mm	694	520	300	42g6	22	68		110	30	590	650	75	250	400
	in	27.32	20.47	11.81	1.6531 1.6526	0.87	2.68		4.33	1.18	23.23	25.59	2.95	9.84	15.75
3 WB 15	mm	844	670	450	42g6	-78	68		110	30	940	1000	75	250	400
	in	33.23	26.38	17.72	1.6531 1.6526	-3.07	2.68		4.33	1.18	37.01	39.37	2.95	9.84	15.75
4 WB 15	mm	994	820	600	42g6	-3	68		110	30	940	1000	75	250	400
	in	39.13	32.28	23.62	1.6531 1.6526	-0.12	2.68		4.33	1.18	37.01	39.37	2.95	9.84	15.75

MODEL	units	ØQ	ØR	S	T	U	W	X	Y	Z	AA	BB	CC	Weight
1 WB 15	mm	15	395	300 ^{±0.2}	1030	265	220	498	12	48	35	490	75	~ 185kg
	in	0.59	15.55	11.819 11.803	40.55	10.43	8.66	19.61	0.47	1.89	1.38	19.29	2.95	~ 408lb
2 WB 15	mm	15	395	300 ^{±0.2}	1030	190	220	498	12	48	35	490	75	~ 290kg
	in	0.59	15.55	11.819 11.803	40.55	7.48	8.66	19.61	0.47	1.89	1.38	19.29	2.95	~ 640lb
3 WB 15	mm	15	395	300 ^{±0.2}	1030	290	220	498	12	48	35	840	75	~ 385kg
	in	0.59	15.55	11.819 11.803	40.55	11.42	8.66	19.61	0.47	1.89	1.38	33.07	2.95	~ 849lb
4 WB 15	mm	15	395	300 ^{±0.2}	1030	215	220	498	12	48	35	840	75	~ 520kg
	in	0.59	15.55	11.819 11.803	40.55	8.46	8.66	19.61	0.47	1.89	1.38	33.07	2.95	~ 1147lb

a) 510 mm for a calibration in N·m with weight in kg (use outer groove);
500 mm for a calibration in N·m with weight in N (use inner groove).

b) Center according to DIN 332-D

NOTE: 3D STEP files for most of our products are available on our website: www.magtrol.com. Other files are available on request.

RELATED PRODUCTS

PB SERIES - POWDER DYNAMOMETER



Fig.3: 1PB 115 | Powder Dynamometer

The PB Series Powder Dynamometers contain, as their name suggests, a magnetic powder. The electrical current passing through the coil generates a magnetic field, which changes the property of the powder, thus producing a smooth braking torque

through friction between rotor and stator. The Powder Dynamometers (PB) produce their rated torque at zero speed. The element to be tested can be loaded at standstill to determine the starting torque.

TANDEM SERIES - WB + PB DYNAMOMETER



Fig.4: 4WB 15 + 4PB 15 | TANDEM

Because the characteristics of the WB and PB dynamometers are complementary, Magtrol is able to offer them mounted in a tandem setup. Each dynamometer (WB and PB) can autonomously operate according to its own characteristics. An electromagnetic clutch is needed for this application which automatically switches off at the maximum speed of the PB Powder Dynamometer and automatically switches on at zero speed.

DUAL SERIES - DOUBLE WB DYNAMOMETER IN TANDEM SETUP

For application requiring higher power in a dedicated speed range, Magtrol offers some of the Eddy Current Dynamometer mounted in line on a common base. This would be for example the models 2WB65+2WB65 (rated torque 40N·m, max speed 24 000rpm, max power 24 kW) or 2WB 115+ WB 115 (rated torque 200N·m, max speed 15 000rpm, max power 60 kW).

DYNAMOMETER OPTIONS

HIGH SPEED (HS)

For testing high-speed motors, Magtrol offers WB Series Eddy-Current Dynamometer with speed ranges up to 65 000 rpm (according to the version, see specification table).

For small or miniature motors, Magtrol models WB23 & WB27 or Microdyne are available for speed up to 100 000 rpm (see specific data sheet).

INDUSTRIAL VERSION (IS)

WB Series Dynamometers are also available in an industrial version (excepte WB 2.7), which includes the base plate, but does not provide torque nor speed measurement.

MECHANICAL ROTOR BLOCKING DEVICE (MB)

As Eddy Current principle is proportional to speed and do not provide braking torque at 0 rpm, a mechanical rotor blocking device, which allows locked rotor testing, is available as an option for the WB Dynamometer.

VERTICAL MOUNTING (V)

Vertical Mounting is available on the Eddy-Current WB Dynamometers. The vertical version has an adapted bearing fitting and its maximum speed is limited.

NOTE: Dimensions of the specific versions can slightly vary from the standard versions. Please, contact our sales technicians for specific drawing.

ORDERING INFORMATION

ORDERING NUMBER	-	WB	---	-	---
1, 2, 3, 4 : Model number					
2.7, 43, 65, 115, 15 : Model number					
HS : High speed version ^{a)}					
IS : Industrial version ^{a)}					
MB : Mechanical rotor bloking device					
V : Vertical Mounting ^{a)}					

Example: 2WB43 Eddy-Current Dynamometer, high speed version would be ordered as **2WB43-HS**
 1WB 115 Eddy-Current Dynamometer, vertical mounting version would be ordered as **1WB115-V**
 3WB 65 Eddy-Current Dynamometer, industrial version would be ordered as **3WB65-IS**

a) Not available for WB 2.7

SYSTEM OPTIONS AND ACCESSORIES

DSP 7000 - HIGH-SPEED PROGRAMMABLE DYNAMOMETER CONTROLLERS

Magtrol's Model DSP7000 High Speed Programmable Dynamometer Controller employs state-of-the-art Digital Signal Processing Technology to provide superior motor testing capabilities. Designed for use with any Magtrol Hysteresis, Eddy-Current or Powder Dynamometer, Magtrol In-Line Torque Transducer or auxiliary instrumentation, the DSP7000 can provide complete PC control via the USB or optional IEEE-488 or RS-232 interface. With up to 500 readings per second, the DSP7000 is ideally suited for both the test lab and the production line.



Fig. 5: DSP 7001 | Programmable Dynamometer Controllers

MODEL 7500 SERIES - POWER ANALYZERS

The Magtrol MODEL 7500 Series Power Analyzer is an easy-to-use instrument ideal for numerous power measurement applications. From DC to 80 kHzAC, the MODEL 7500 Series measures volts, amps, watts, volt-amps, frequency, crest factor, Vpeak, Apeak and power factor in one convenient display. They may be used either as stand-alone instruments or in conjunction with any Magtrol Hysteresis, Eddy-Current or Powder Brake Dynamometer; any Magtrol Dynamometer Controller and M-TEST Software for more demanding motor test applications.



Fig. 7: MODEL 7510 | Power Analyzers

TSC 401 - TORQUE/SPEED CONDITIONER

The TSC401 is the Torque/Speed Conditioner used to connect Magtrol Eddy-Current (WB Series) or Powder (PB Series) Dynamometers to the DSP7000 Controller. Powered by the DSP7000, and based on a precision instrumentation amplifier, the unit amplifies and filters the torque signal. It also provides power supply and connections for the speed pickup sensor which is located in the dynamometer.

DES SERIES - POWER SUPPLIES

DES Series Power Supplies are specially designed for the full range of Magtrol's Eddy-current and Powder brake dynamometers with the design goal providing the best response time. The DES Series supplies are packaged in an industrial housing made of cast aluminum. This housing must be installed directly on the test bench, ideally on a thermal conductive surface.



Fig. 6: Custom Motor Test System with WB Series brake

M-TEST - MOTOR TESTING SOFTWARE

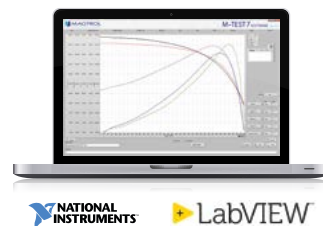

Magtrol M-TEST is an advanced motor testing software (Windows® based) for data acquisition. Used with a Magtrol Programmable Dynamometer Controller (e.g. DSP7000), M-TEST works with any Magtrol

Dynamometer or In-Line Torque Transducer to help determine the performance characteristics of a motor under test. Up to 63 parameters are calculated and displayed utilizing M-TEST's feature-rich testing and graphing capabilities.

An integral component of any Magtrol Motor Test System, M-TEST performs ramp, curve, manual, pass/fail, coast and overload to trip tests in a manner best suited to the overall efficiency of the test rig. Written in LabVIEW™, M-TEST has the flexibility to test a variety of motors in a multitude of configurations. The data generated from this user-friendly program can be stored, displayed and printed in tabular or graphical formats, and is easily imported into a spreadsheet.

Magtrol can also make custom modifications to the software to meet additional motor testing requirements.

CMTS - CUSTOM MOTOR TEST SYSTEMS

MAGTROL provides motor testing components to turnkey solutions for all your motor testing needs. Typical test benches include: dynamometers, 4-Quadrant loading motors, tables, fixtures, control racks, power supplies, power analyzers, ohmmeters, temperature measurement and dedicated M-TEST software. Other sensors can be integrated upon request.