

PB SERIES

POWDER BRAKE DYNAMOMETERS

Magtrol offers 3 types of dynamometer brakes to absorb load: Hysteresis (**HD Series**), Eddy-Current (**WB Series**) and Magnetic Powder (**PB Series**). Each type of Dynamometer has advantages and limitations and choosing the correct one will depend largely on the type of testing to be performed. With over 50 standard models to choose from, Magtrol Sales professionals are readily available to assist in selecting the proper Dynamometer to meet your testing needs.

FEATURES

- 12 Models with Maximum Torque
600 mN·m ... 1 200 N·m (84 oz·in ... 885 lb·ft)
- Braking Power: 150 W ... 48 kW
- Stable Braking Torque
- Low Moment of Inertia
- Operation in Either Rotational Direction
- Braking Torque Measurement Integrated
- Integrated Optical Speed Sensor
- Special designs available upon request

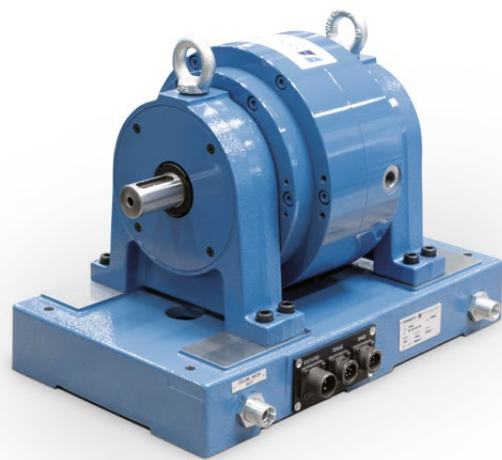

Fig. 1: 1PB115 | Eddy-Current Dynamometer

DESCRIPTION

Powder Brake Dynamometers (PB Series) are ideal for applications operating in the low to middle speed range or when operating in the middle to high torque range. Powder Brakes provide full torque at zero speed and are water-cooled, allowing for power ratings up to 48 kW. PB Series Powder Dynamometers integrate a torque measuring system with an accuracy ratings $\pm 0.3\%$... $\pm 0.5\%$ full scale, depending on size and system configuration.

APPLICATIONS

Mounted on test benches, the PB Series Powder Dynamometers allow performance and reliability testing on driving elements such as servomotors, geared motor, gearbox, windshield wiper motor, starter motor, fans, drills, hydraulic transmission systems and motors for domestic appliances.

POWDER DYNAMOMETER OPERATING PRINCIPLES

The PB Series - Powder Dynamometers contain, as their name suggests, a magnetic powder. The electrical current passing through the coil generates a magnetic field, which changes the property of the powder, thus producing a smooth braking torque through friction between rotor and stator. The Powder Dynamometers (PB) produce their rated torque at zero speed. The element to be tested can be loaded at standstill to determine the starting torque.

OPTICAL SPEED SENSOR

Each PB Series Dynamometer has an optical speed sensor delivered as standard. PB 2.7 & PB 43 has an optical speed sensor with a 30 PPR (Pulses Per Revolution); PB 65, PB 115 & PB 15 has an optical speed sensor with a 60 PPR.

For higher speed resolution in low speed applications, Magtrol offers a 600 PPR or 6 000 PPR encoder as an option.

DYNAMOMETER CONFIGURATIONS

The Dynamometers can be complemented by various electronic modules such as the DES Series (Power Supply), TSC401 (Torque/Speed Conditioner) and DSP7000 (High Speed Programmable Dynamometer Controller).

Magtrol also offers In-Line Torque Transducers (TS Series or TM Series) or Torque Flange (TF Series) for extremely

accurate torque and speed measurement. For a dynamic, high-precision system, the torque transducer can be mounted in line between the unit under test and the dynamometer, providing a torque accuracy of 0.1 %.

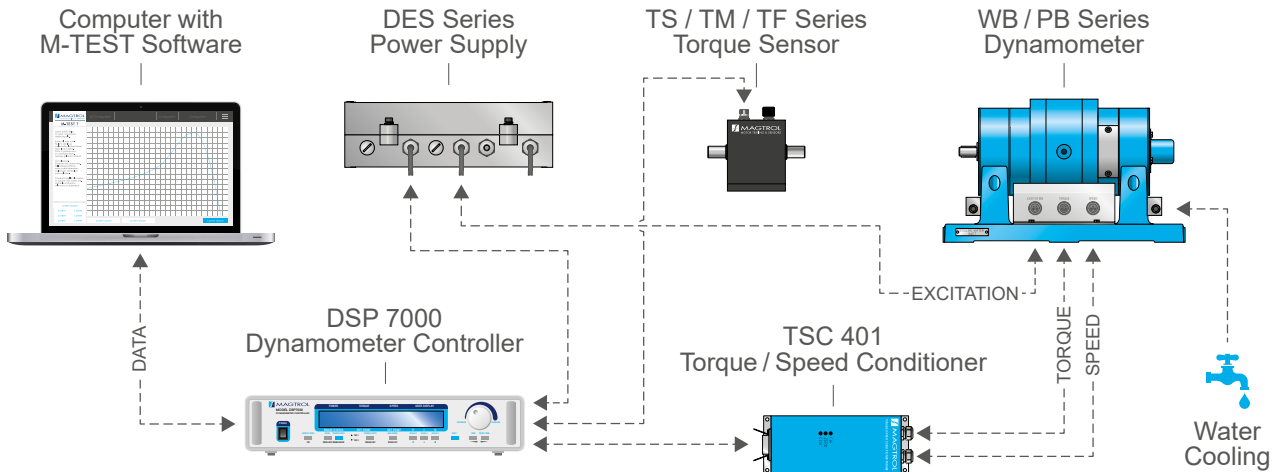

Fig. 2: Configuration of the PB Series Dynamometer with its accessories

SPECIFICATIONS

NOTE: For continuous operating (≥ 2 hours) at constant torque or power, please consider 20% reserve in both torque & power

MODEL	RATED TORQUE		DRAG TORQUE DE-ENERGIZED		NOMINAL INPUT INERTIA		RATED POWER	RATED SPEED ^{a)}	MAX. SPEED	EXCITATION CURRENT
	N·m	oz·in	mN·m	oz·in	kg·m ²	lb·ft·s ²	W	rpm	rpm	A
1PB2.7	0.6	84	18	2.54	1.49×10^{-5}	1.09×10^{-5}	150			0.5 ^{b)}
2PB2.7	1.2	169	30	4.24	2.33×10^{-5}	1.71×10^{-5}	300	2390	10000	1.0 ^{b)}
4PB2.7	2.4	339	48	6.79	4.03×10^{-5}	2.97×10^{-5}	600			2.0 ^{b)}
1PB43	5.0	708	100	14.10	1.41×10^{-4}	1.03×10^{-4}	500	955	4000	1.0 ^{b)}
2PB43	10.0	1416	200	28.30	2.40×10^{-4}	1.77×10^{-4}	1000			2.0 ^{b)}

MODEL	RATED TORQUE		DRAG TORQUE DE-ENERGIZED		NOMINAL INPUT INERTIA		RATED POWER	RATED SPEED ^{a)}	MAX. SPEED	EXCITATION CURRENT
	N·m	lb·ft	N·m	lb·in	kg·m ²	lb·ft·s ²	kW	rpm	rpm	A
1PB65	25	18.4	0.5	4.42	0.92×10^{-3}	6.78×10^{-4}	1.5	570	3000	2.5 ^{c)}
2PB65	50	36.8	1.0	8.85	1.71×10^{-3}	1.26×10^{-3}	3.0			5.0 ^{c)}
1PB115	100	73.7	2.0	17.70	1.24×10^{-2}	9.14×10^{-3}	5.0	480	3000	2.5 ^{c)}
2PB115	200	147.5	4.0	35.40	2.50×10^{-2}	1.84×10^{-2}	10.0			5.0 ^{c)}
1PB15	300	221.0	6.0	53.10	5.40×10^{-2}	3.98×10^{-2}	12.0			4.0 ^{d)}
2PB15	600	442.0	12.0	106.20	1.08×10^{-1}	7.96×10^{-2}	24.0	382	2000	7.5 ^{d)}
4PB15	1200	885.0	24.0	212.41	2.16×10^{-1}	1.59×10^{-1}	48.0			12.0 ^{d)}

a) Depending on torsional stiffness of the drive line, magnetic powder may generate a "slip-stick" effect (torsional vibration) at low speed (around 10rpm)

b) Voltage @ 20°C : 24 V

c) Voltage @ 20°C : 30 V

d) Voltage @ 20°C : 45 V

PB 2.7 TORQUE-SPEED-POWER CURVES

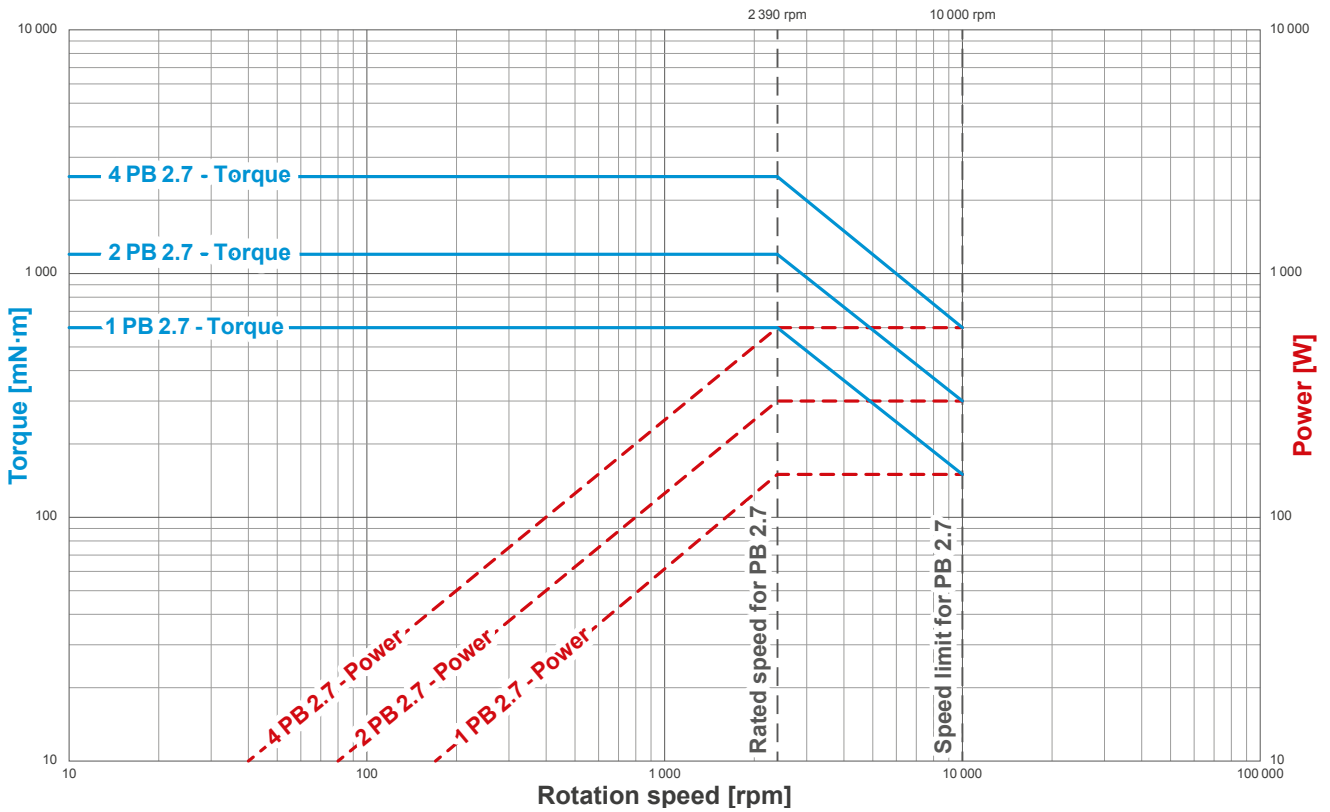

PB 43 & PB 65 TORQUE-SPEED-POWER CURVES

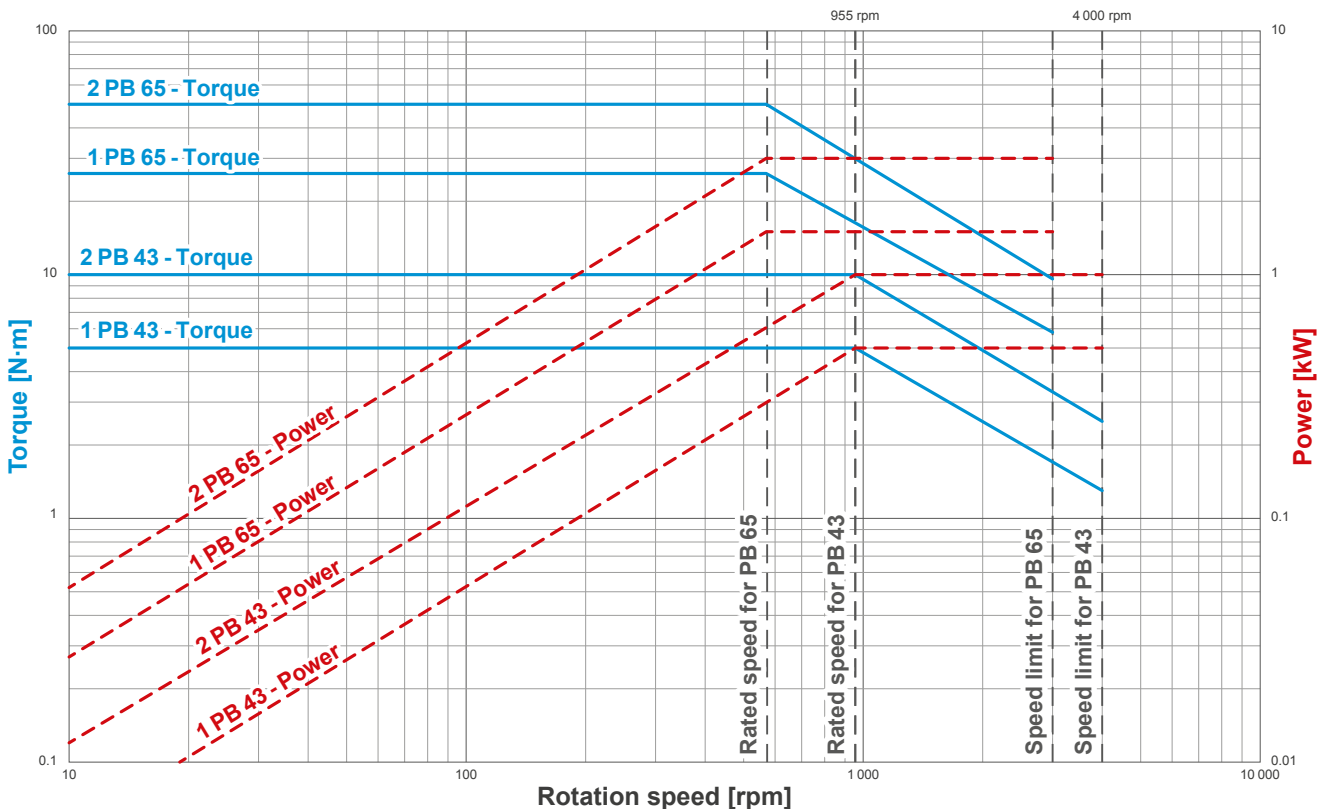

PB 115 TORQUE-SPEED-POWER CURVES

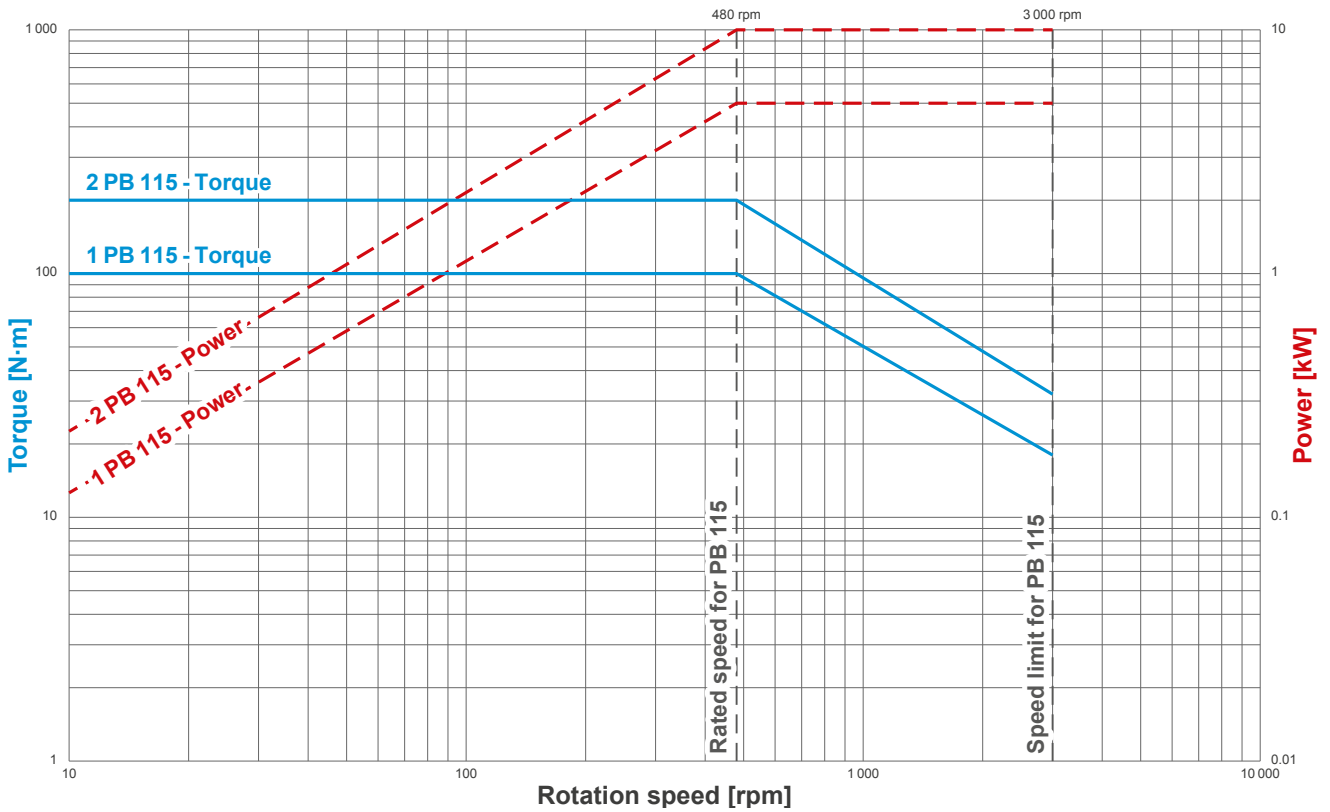

PB 15 TORQUE-SPEED-POWER CURVES

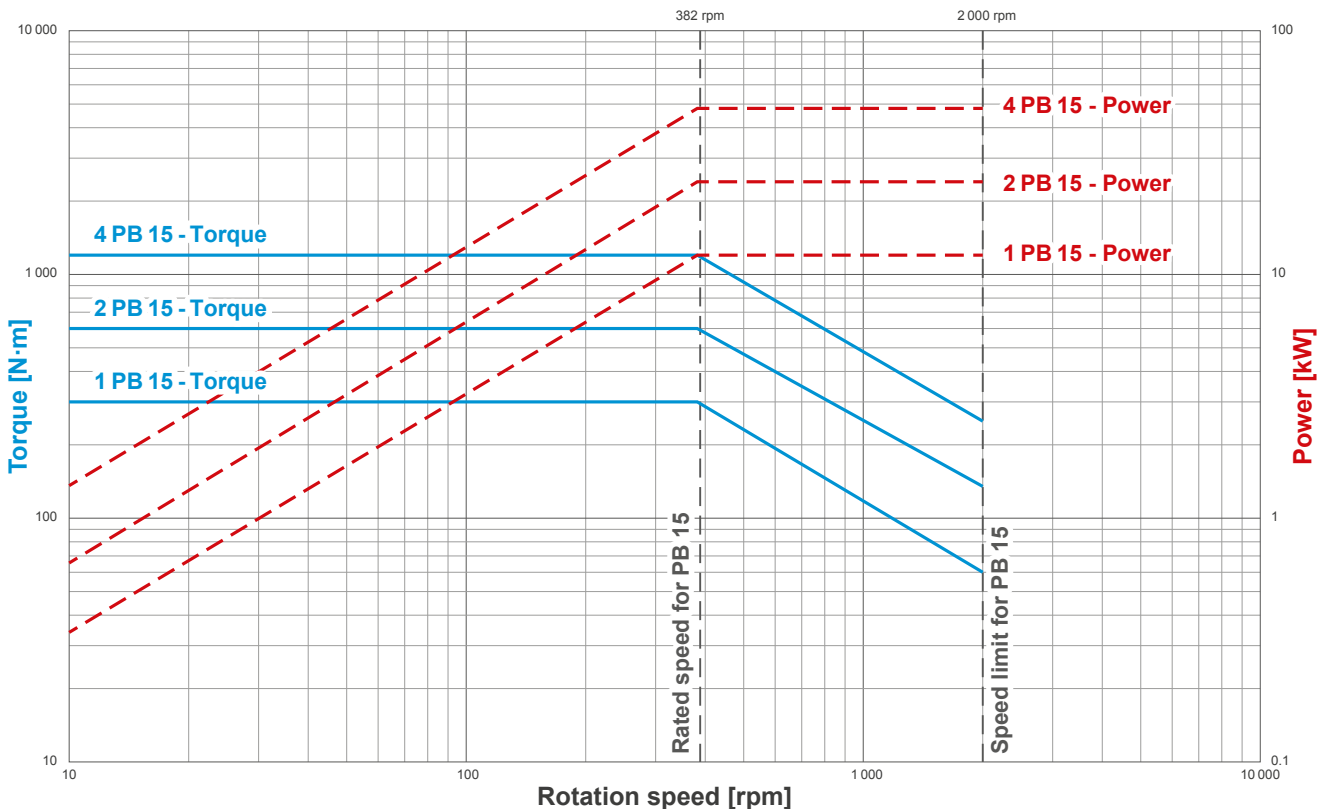

PB 2.7 DIMENSIONS

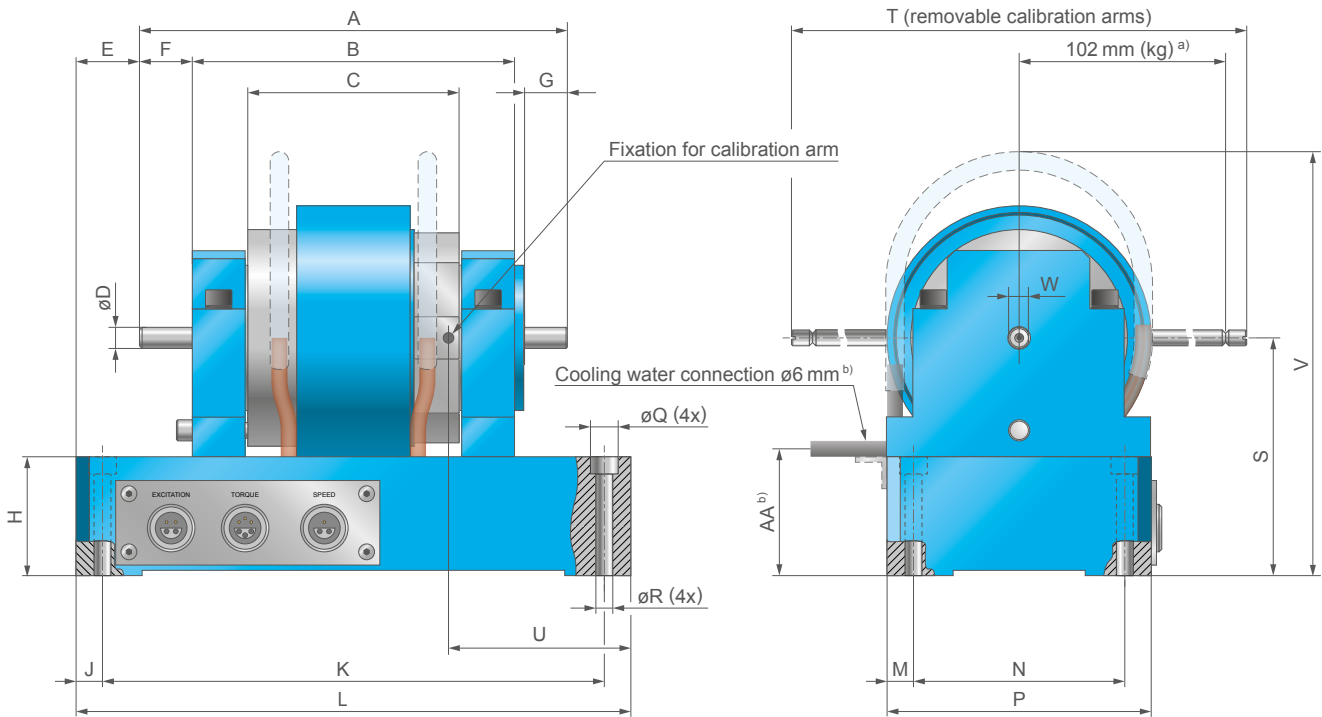

CAUTION: All PB Series Dynamometers must be water cooled.

NOTE: Original dimensions are in metric units. Dimensions converted to English units have been rounded up to 4 decimal places.

MODEL	units	A	B	C	øD	E	F	G	H	J	K	L	M	N
1PB-2.7	mm	138	98	56	8h5	36	20	16	45	10	190	210	10	80
	in	5.43	3.86	2.2	0.3148 0.3149	1.42	0.79	0.63	1.77	0.39	7.48	8.27	0.39	3.15
2PB2.7	mm	162	122	80	8h5	24	20	16	45	10	190	210	10	80
	in	6.38	4.8	3.15	0.3148 0.3149	0.94	0.79	0.63	1.77	0.39	7.48	8.27	0.39	3.15
4PB2.7	mm	210	170	128	8h5	-	20	16	45	10	190	210	10	80
	in	8.27	6.69	5.04	0.3148 0.3149	-	0.79	0.63	1.77	0.39	7.48	8.27	0.39	3.15

MODEL	units	P	øQ	øR	S	T	U	V	W	AA	Weight
1PB-2.7	mm	100	10.5	6.4	90 ^{±0.1}	220	81	152	7.6	48	~ 4.2kg
	in	3.94	0.413	0.252	0.547 0.539	8.66	2.72	5.98	0.299	1.89	~ 9.3lb
2PB2.7	mm	100	10.5	6.4	90 ^{±0.1}	220	69	152	7.6	48	~ 5.3kg
	in	3.94	0.413	0.252	0.547 0.539	8.66	2.72	5.98	0.299	1.89	~ 11.7lb
4PB2.7	mm	100	10.5	6.4	90 ^{±0.1}	220	45	152	7.6	48	~ 7.5kg
	in	3.94	0.413	0.252	0.547 0.539	8.66	1.77	5.98	0.299	1.89	~ 16.6lb

a) For calibration in N·m with weight in kg

NOTE: 3D STEP files of most of our products are available on our website: www.magtrol.com ; other files are available on request.

PB 43 DIMENSIONS

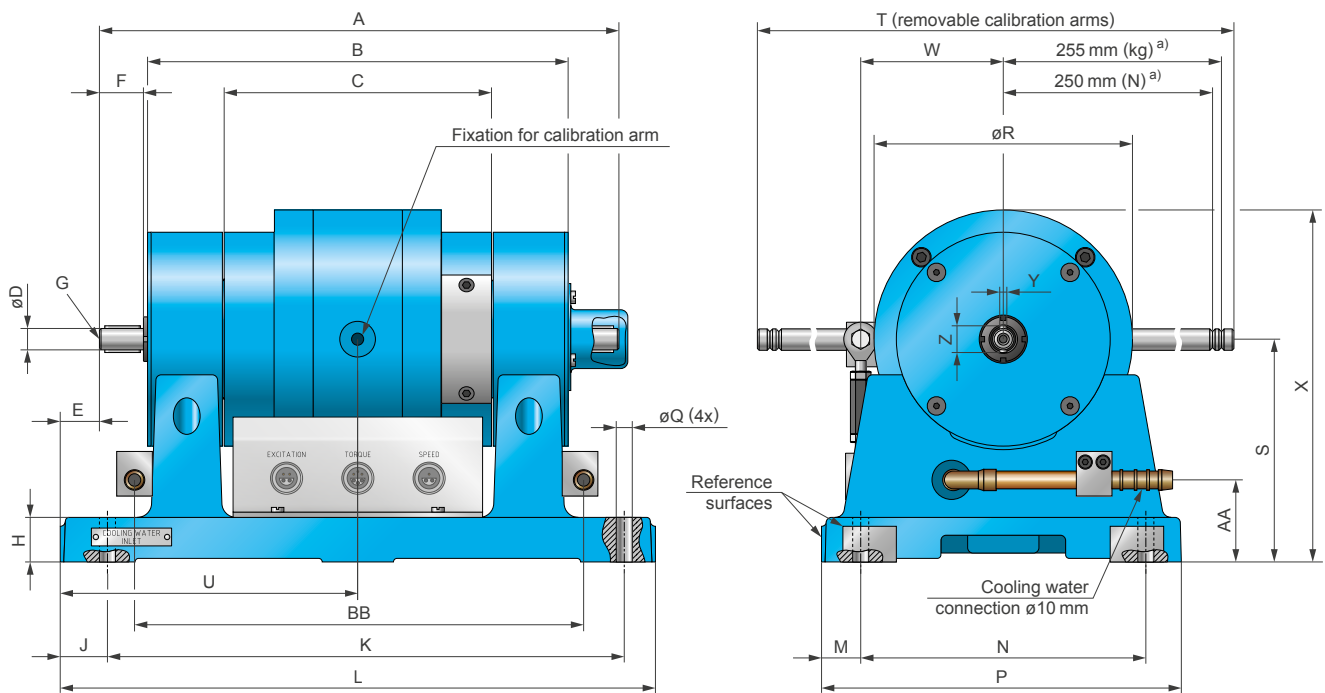

CAUTION: All PB Series Dynamometers must be water cooled.

NOTE: Original dimensions are in Metric units. Dimensions converted to English units have been rounded up to 4 decimal places.

MODEL	units	A	B	C	øD	E	F	G ^{b)}	H	J	K	L	M	N	P
1PB43	mm	240	186	100	12h6	22	25	M4	25	22	240	284	22	160	202
	in	9.45	7.32	3.94	0.4724 0.4721	0.87	0.98		0.98	0.87	9.45	11.18	0.87	6.30	7.95
2PB43	mm	290	236	150	12h6	22	25		25	22	290	334	22	160	202
	in	11.42	9.29	5.91	0.4724 0.4721	0.87	0.98		0.98	0.87	11.42	13.15	0.87	6.30	7.95
MODEL	units	øQ	øR	S	T	U	W	X	Y	Z	AA	BB	Weight		
1PB43	mm	9	145	125±0.05	524	153	80	198	4h9	15	46	202	~ 24 kg		
	in	0.35	5.71	4.923 4.919	20.63	6.02	3.15	7.80	0.1574 0.1563	0.59	1.81	7.95	~ 53 lb		
2PB43	mm	9	145	125±0.05	524	167	80	198	4h9	15	46	252	~ 31 kg		
	in	0.35	5.71	4.923 4.919	20.63	6.57	3.15	7.80	0.1574 0.1563	0.59	1.81	9.92	~ 69 lb		

a) 255 mm for a calibration in N·m with weight in kg (use outer groove);
250 mm for calibration in N·m with weight in N (use inner groove)

b) Center according to DIN 332-D

NOTE: 3D STEP files of most of our products are available on our website: www.magtrol.com ; other files are available on request.

PB 65 DIMENSIONS

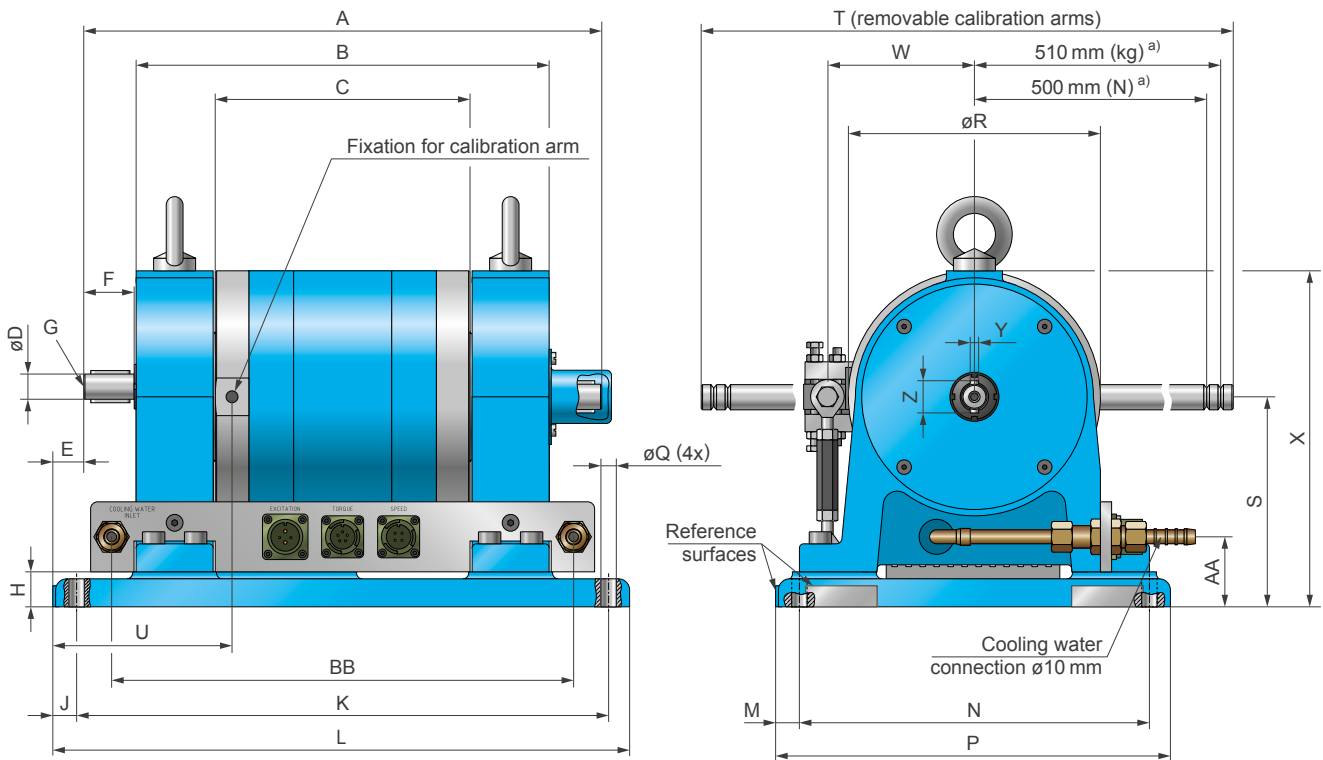

CAUTION: All PB Series Dynamometers must be water cooled.

NOTE: Original dimensions are in metric units. Dimensions converted to English units have been rounded up to 4 decimal places.

MODEL	units	A	B	C	ØD	E	F	G ^{b)}	H	J	K	L	M	N	P
1PB65	mm	300	225	112	18h6	22	36	M5	25	17	310	342	17	250	282
	in	11.81	8.86	4.41	0.7086 0.7083	0.87	1.42		0.98	0.67	12.2	13.46	0.67	9.84	11.10
2PB65	mm	370	295	182	18h6	22	36		25	17	380	412	17	250	282
	in	14.57	11.61	7.17	0.7086 0.7083	0.87	1.42		0.98	0.67	14.96	16.22	0.67	9.84	11.10

MODEL	units	ØQ	ØR	S	T	U	W	X	Y	Z	AA	BB	Weight
1PB65	mm	11	180	150±0.1	1034	128	105	240	6h9	23	50	260	~ 55 kg
	in	0.43	7.09	5.909 5.902	40.71	5.04	4.13	9.45	0.2362 0.2351	0.91	1.97	10.24	~ 122 lb
2PB65	mm	11	180	150±0.1	1034	128	105	240	6h9	23	50	330	~ 70 kg
	in	0.43	7.09	5.909 5.902	40.71	5.04	4.13	9.45	0.2362 0.2351	0.91	1.97	12.99	~ 155 lb

a) 510 mm for a calibration in N·m with weight in kg (use outer groove);
500 mm for a calibration in N·m with weight in N (use inner groove).

b) Center according to DIN 332-D

NOTE: 3D STEP files of most of our products are available on our website: www.magtrol.com ; other files are available on request.

PB 115 DIMENSIONS

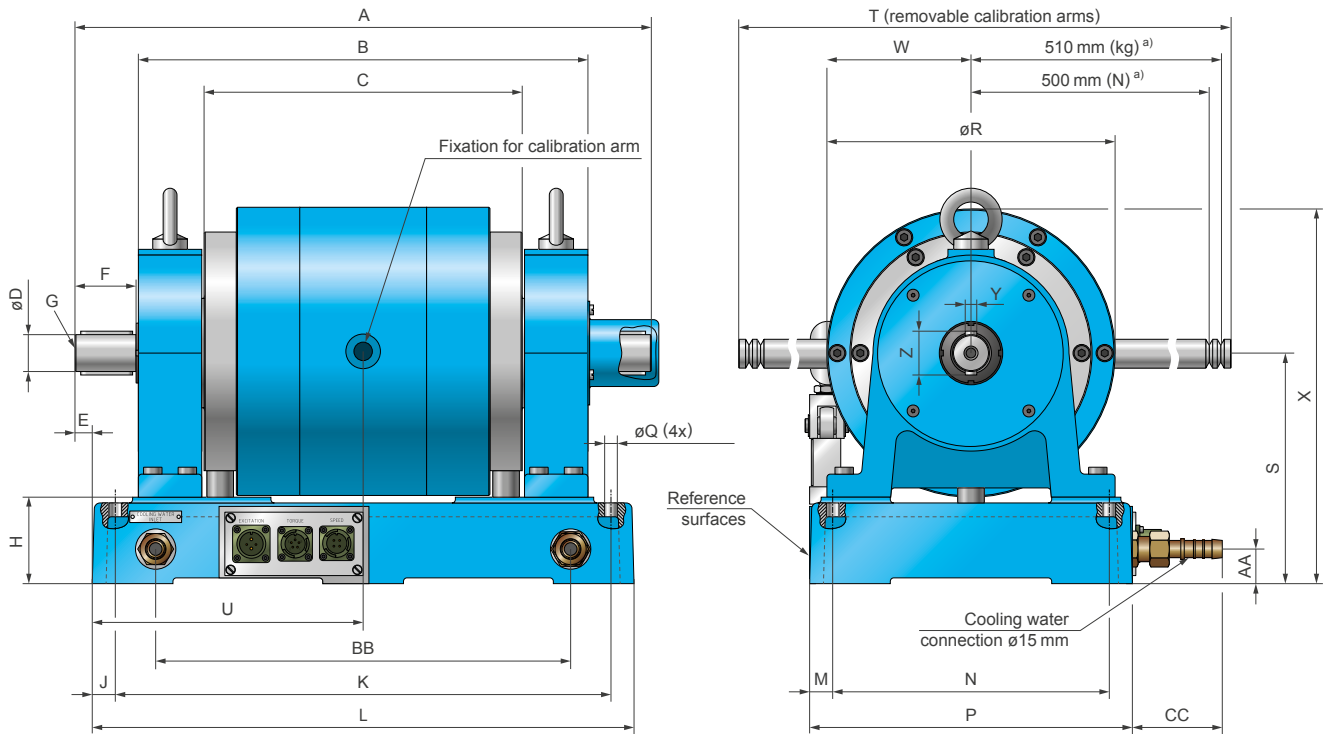

CAUTION: All PB Series Dynamometers must be water cooled.

NOTE: Original dimensions are in metric units. Dimensions converted to imperial units have been rounded up to 4 decimal places.

MODEL	units	A	B	C	øD	E	F	G ^{b)}	H	J	K	L	M	N	P
1PB115	mm	390	280	166	32h6	-40	54	M8	75	20	430	470	40	200	280
	in	15.35	11.02	6.54	1.2598 1.2593	-1.57	2.13		2.95	0.79	16.93	18.50	1.57	7.87	11.02
2PB115	mm	500	390	276	32h6	15	54		75	20	430	470	40	200	280
	in	19.69	15.35	10.87	1.2598 1.2593	0.59	2.13		2.95	0.79	16.93	18.50	1.57	7.87	11.02

MODEL	units	øQ	øR	S	T	U	W	X	Y	Z	AA	BB	CC	Weight
1PB115	mm	11	250	200±0.1	1038	197	125	325	10h9	38	30	360	80	~ 80 kg
	in	0.43	9.84	7.878 7.870	40.87	7.76	4.92	12.80	0.3937 0.3932	1.50	1.18	14.17	3.15	~ 177 lb
2PB115	mm	11	250	200±0.1	1038	235	125	325	10h9	38	30	360	80	~ 130 kg
	in	0.43	9.84	7.878 7.870	40.87	9.25	4.92	12.80	0.3937 0.3932	1.50	1.18	14.17	3.15	~ 287 lb

a) 510 mm for a calibration in N·m with weight in kg (use outer groove);
500 mm for a calibration in N·m with weight in N (use inner groove).

b) Center according to DIN 332-D

NOTE: 3D STEP files of most of our products are available on our website: www.magtrol.com ; other files are available on request.

PB 15 DIMENSIONS

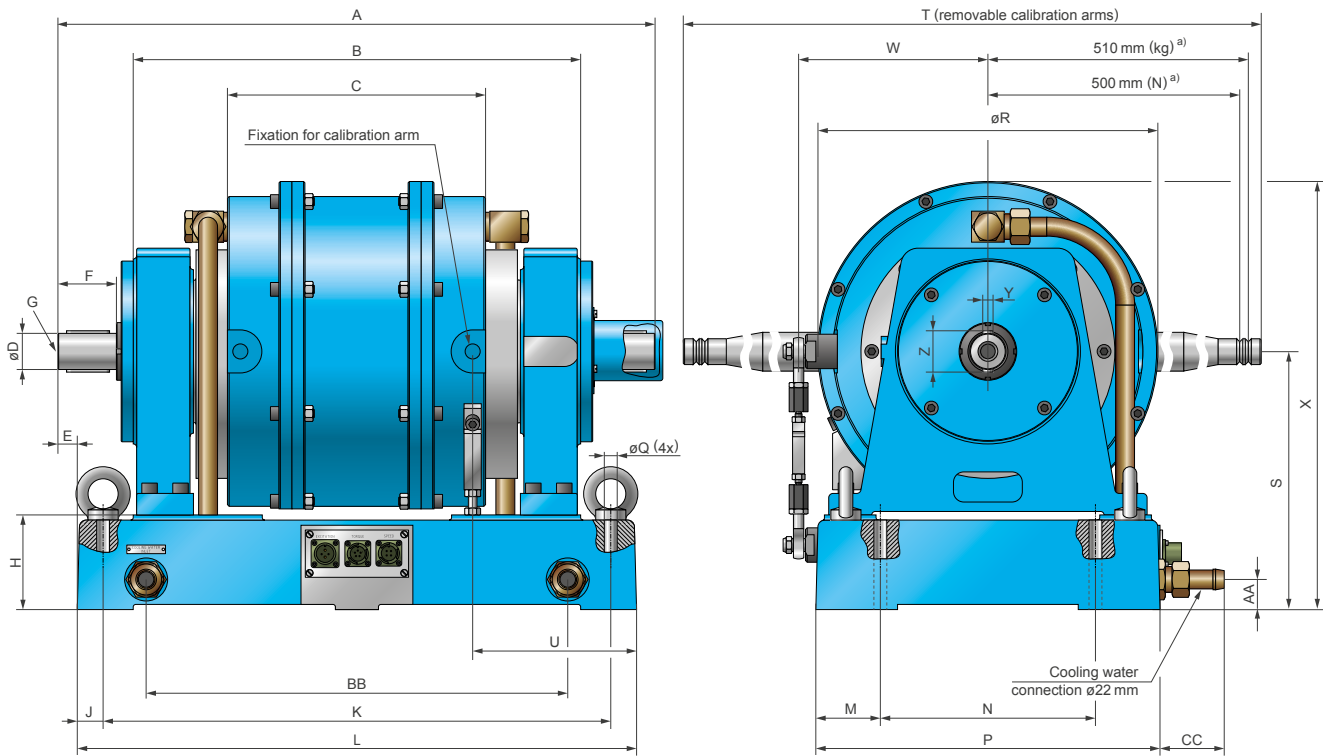

CAUTION: All PB Series Dynamometers must be water cooled.

NOTE: Original dimensions are in metric units. Dimensions converted to imperial units have been rounded up to 4 decimal places.

MODEL	units	A	B	C	øD	E	F	G ^{b)}	H	J	K	L	M	N	P
1PB15	mm	544	370	150	42g6	-53	68	M8	110	30	590	650	75	250	400
	in	21.42	14.57	5.91	1.6531 1.6526	-2.09	2.68		4.33	1.18	23.23	25.59	2.95	9.84	15.75
2PB15	mm	694	520	300	42g6	22	68		110	30	590	650	75	250	400
	in	27.32	20.47	11.81	1.6531 1.6526	0.87	2.68		4.33	1.18	23.23	25.59	2.95	9.84	15.75
4PB15	mm	994	820	600	42g6	-3	68		110	30	940	1000	75	250	400
	in	39.13	32.28	23.62	1.6531 1.6526	-0.12	2.68		4.33	1.18	37.01	39.37	2.95	9.84	15.75

MODEL	units	øQ	øR	S	T	U	W	X	Y	Z	AA	BB	CC	Weight
1PB15	mm	15	395	300 ^{±0.2}	1030	265	220	498	12 h9	48	35	490	75	~ 185 kg
	in	0.59	15.55	11.819 11.803	40.55	10.43	8.66	19.61	0.471 0.472	1.89	1.38	19.29	2.95	~ 408 lb
2PB15	mm	15	395	300 ^{±0.2}	1030	190	220	498	12 h9	48	35	490	75	~ 290 kg
	in	0.59	15.55	11.819 11.803	40.55	7.48	8.66	19.61	0.471 0.472	1.89	1.38	19.29	2.95	~ 640 lb
4PB15	mm	15	395	300 ^{±0.2}	1030	215	220	498	12 h9	48	35	840	75	~ 520 kg
	in	0.59	15.55	11.819 11.803	40.55	8.46	8.66	19.61	0.471 0.472	1.89	1.38	33.07	2.95	~ 1147 lb

a) 510 mm for a calibration in N·m with weight in kg (use outer groove);
500 mm for a calibration in N·m with weight in N (use inner groove).

b) Center according to DIN 332-D

NOTE: 3D STEP files of most of our products are available on our website: www.magtrol.com ; other files are available on request.

RELATED PRODUCTS

WB SERIES - EDDY-CURRENT DYNAMOMETER



Fig. 3: 1WB43 | Eddy-Current Dynamometer

Eddy-Current Brake Dynamometers WB Series are ideal for applications requiring high speeds and also when operating in the middle to high power range. Eddy-Current Brakes provide increasing torque as the speed increases,

reaching peak torque at rated speed. The dynamometers have low inertia as a result of small rotor diameter. Brake cooling is provided by a water circulation system, which passes inside the stator to dissipate heat generated by the braking power. The water cooling in the WB provides high continuous power ratings (max. 140 kW).

TANDEM SERIES - WB + PB DYNAMOMETER



Fig. 4: 4WB15 + 4PB15 | TANDEM

Because the characteristics of the WB and PB dynamometers are complementary, Magtrol is able to offer them mounted in a tandem setup. Each dynamometer (WB and PB) can autonomously operate according to its own characteristics. An electromagnetic clutch is needed for this application which automatically switches off at the maximum speed of the PB Powder Dynamometer and automatically switches on at zero speed.

DUAL SERIES - DOUBLE WB DYNAMOMETER IN TANDEM SETUP

For application requiring higher power in a dedicated speed range, Magtrol offers some of the Eddy Current Dynamometer mounted in line on a common base. This would be for example the models 2WB65+2WB65 (rated torque 40 N·m, max speed 24 000 rpm, max power 24 kW) or 2WB115+2WB115 (rated torque 200 N·m, max speed 15 000 rpm, max power 60 kW).

DYNAMOMETER OPTIONS

SPEED ENCODER (DG)

PB Series Dynamometers, are equipped with a encoder (optical speed sensor) 30 PPR (PB2.7 & PB43) or 60 PPR (PB65, PB115 & PB15) encoder.

On PB Dynamometers, a 600 PPR or 6000 PPR encoder is available as an option for low speed applications.

INDUSTRIAL VERSION (IS)

PB Series Dynamometers are also available in an industrial version (excepte PB2.7), which includes the base plate, but does not provide torque nor speed measurement.

NOTE: Dimensions of the specific versions can slightly vary from the standard versions. Please, contact our sales technicians for specific drawing.

ORDERING INFORMATION

ORDERING NUMBER						
1, 2, 4	:	Model number				
2.7, 43, 65, 115, 15	:	Model number				
IS	:	Industrial version ^{a)}				
DG-0600	:	Speed Encoder 600 PPR ^{b)}				
DG-6000	:	Speed Encoder 6000 PPR ^{b)}				

Examples:

2 PB43 Powder Dynamometer, Industrial version would be ordered as: **2PB43-IS**

4 PB115 Powder Dynamometer, with speed pickup 600 PPR would be ordered as: **4PB115-DG0600**

1 PB2.7 Powder Dynamometer would be ordered as: **1PB2.7**

a) Not available for PB2.7

b) PPR means Pulses Per Revolution

SYSTEM OPTIONS AND ACCESSORIES

DSP 7000 - HIGH-SPEED PROGRAMMABLE DYNAMOMETER CONTROLLERS

Magtrol's Model DSP7000 High Speed Programmable Dynamometer Controller employs state-of-the-art Digital Signal Processing Technology to provide superior motor testing capabilities. Designed for use with any Magtrol Hysteresis, Eddy-Current or Powder Dynamometer, Magtrol In-Line Torque Transducer or auxiliary instrumentation, the DSP7000 can provide complete PC control via the USB or optional IEEE-488 or RS-232 interface. With up to 500 readings per second, the DSP7000 is ideally suited for both the test lab and the production line.



Fig. 5: DSP 7001 | Programmable Dynamometer Controllers

MODEL 7500 - POWER ANALYZERS

The Magtrol MODEL7500 Power Analyzer is an easy-to-use instrument ideal for numerous power measurement applications. From DC to 80kHzAC, the MODEL7500 Series measures volts, amps, watts, volt-amps, frequency, crest factor, Vpeak, Apeak and power factor in one convenient display. They may be used either as stand-alone instruments or in conjunction with any Magtrol Hysteresis, Eddy-Current or Powder Brake Dynamometer; any Magtrol Dynamometer Controller and M-TEST Software for more demanding motor test applications.



Fig. 7: MODEL 7500 | Power Analyzers

TSC 401 - TORQUE/SPEED CONDITIONER

The TSC401 is the Torque/Speed Conditioner used to connect Magtrol Eddy-Current (WB Series) or Powder (PB Series) Dynamometers to the DSP7000 Controller. Powered by the DSP7000, and based on a precision instrumentation amplifier, the unit amplifies and filters the torque signal. It also provides power supply and connections for the speed pickup sensor which is located in the dynamometer.

DES SERIES - POWER SUPPLIES

DES Series Power Supplies are specially designed for the full range of Magtrol's Eddy-current and Powder brake dynamometers with the design goal providing the best response time. The DES Series supplies are packaged in an industrial housing made of cast aluminum. This housing must be installed directly on the test bench, ideally on a thermal conductive surface.



Fig. 6: Custom Motor Test System with WB brake

M-TEST - MOTOR TESTING SOFTWARE

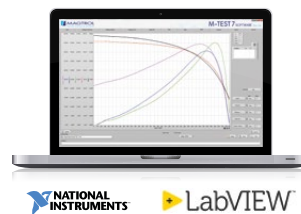

Magtrol M-TEST is an advanced motor testing software (Windows® based) for data acquisition. Used with a Magtrol Programmable Dynamometer Controller (e.g. DSP7000), M-TEST works with any Magtrol

Dynamometer or In-Line Torque Transducer to help determine the performance characteristics of a motor under test. Up to 63 parameters are calculated and displayed utilizing M-TEST's feature-rich testing and graphing capabilities.

An integral component of any Magtrol Motor Test System, M-TEST performs ramp, curve, manual, pass/fail, coast and overload to trip tests in a manner best suited to the overall efficiency of the test rig. Written in LabVIEW™, M-TEST has the flexibility to test a variety of motors in a multitude of configurations. The data generated from this user-friendly program can be stored, displayed and printed in tabular or graphical formats, and is easily imported into a spreadsheet.

Magtrol can also make custom modifications to the software to meet additional motor testing requirements.

CMTS - CUSTOM MOTOR TEST SYSTEMS

MAGTROL provides motor testing components to turnkey solutions for all your motor testing needs. Typical test benches include: dynamometers, 4-quadrant loading motors, tables, fixtures, control racks, power supplies, power analyzers, ohmmeters, temperature measurement and dedicated M-TEST software. Other sensors can be integrated upon request.