



Hot runner nozzle type 5SHF/5DHF with AHJ5

Open single nozzle with thick-film heating element (BlueFlow®) and heated adapter AHJ5

TECHNICAL DATA

5SHF/5DHF

Melt channel Ød	4.8 mm						
Nozzle type	SHF – open with tip DHF – open with straight outlet						
Operating voltage	230 V _{AC} *						
Nominal length of the nozzle (L) in mm	50	60	80	100	120	150	180
	■	■	■	■	■	□	□

AHJ5

Melt channel Ød	5.0 mm	
Operating voltage	230 V _{AC} *	
Adapter	straight (G)/radius (R)/ angle (W)	

Contact us for other nozzle lengths!

*Volts alternating current
 available on request

NOTE

Power connector CHF and thermocouple connector CMLK are to be ordered separately.

BlueFlow® hot runner nozzle type SHF/DHF is not intended for sale or use in the USA or Canada!

WEBCODE
21050



SHF – open nozzle with tip
version "Tip"
Antechamber version A

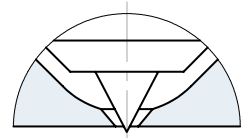

DHF – open nozzle with straight outlet
version C
Antechamber version A

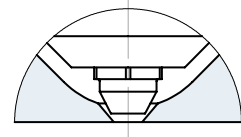

DHF – open nozzle with straight outlet
version A
Antechamber version C

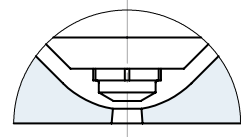



INSTALLATION

Open nozzle with tip
Nozzle type version C
Antechamber version A

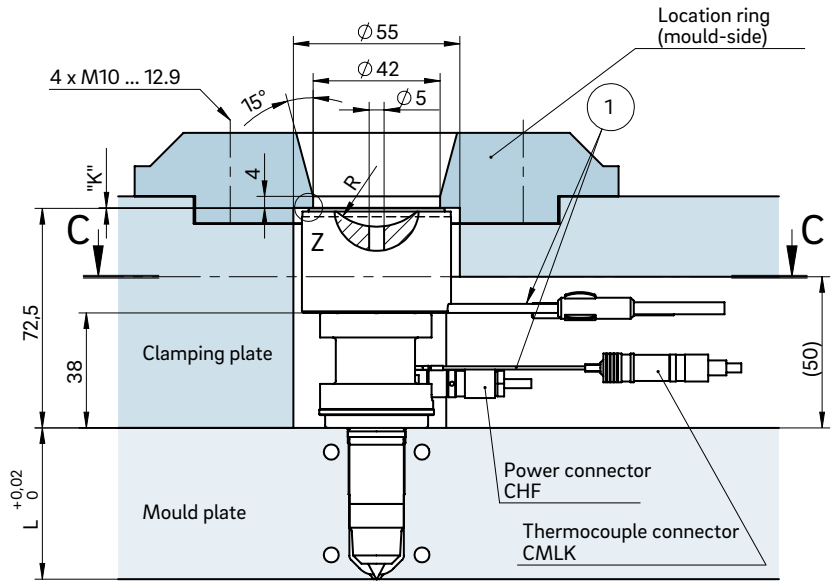
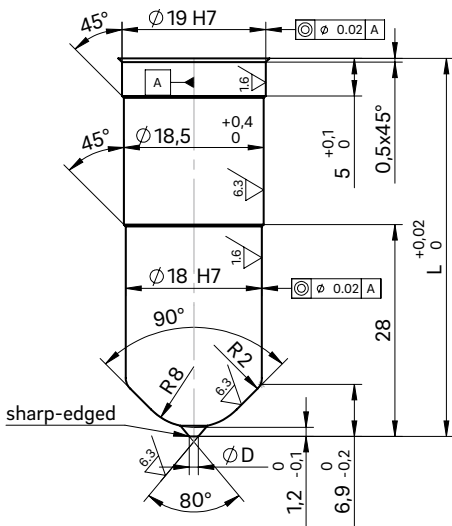

Cross-section C-C: Cutout for nozzle head, power and thermocouple plug connections

Open nozzle with straight outlet
Nozzle type version A
Antechamber version C

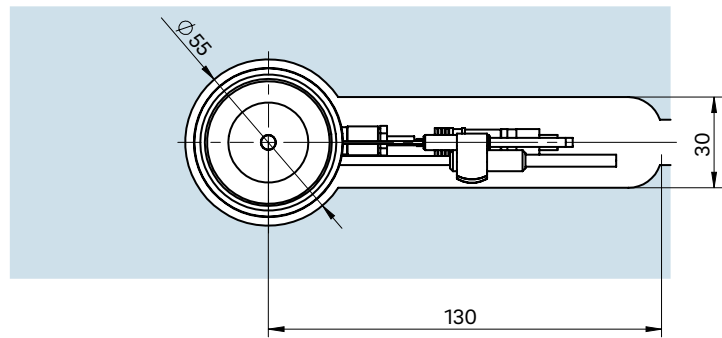
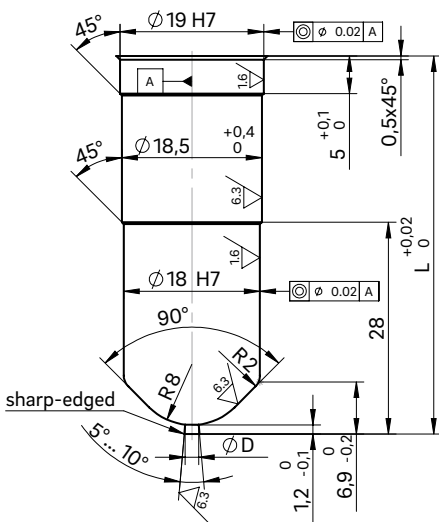

① Power and thermocouple plug connections in this area can be bent once; minimum radius: R8

Dimension "K" required for heat expansion is to be ensured by grinding the location ring! Determine the difference between the height of the nozzle (with mount) and the height of the structure when installed! ΔT specifies the temperature differential between the processing temperature and the mould temperature!

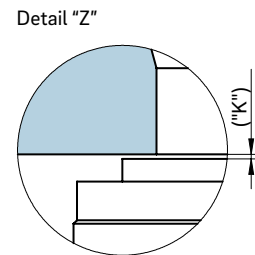

ΔT (°C)	100	150	200	250	300	350
K (mm)	0.06	0.08	0.09	0.11	0.13	0.16