

# HD SERIES

## HYSTERESIS DYNAMOMETERS

MAGTROL offers 3 types of dynamometer brakes to absorb load: Hysteresis (**HD Series**), Eddy-Current (**WB Series**) and Magnetic Powder (**PB Series**). Each type of Dynamometer has advantages and limitations and choosing the correct one will depend largely on the type of testing to be performed. With over 50 standard models to choose from, Magtrol Sales professionals are readily available to assist in selecting the proper Dynamometer to meet your testing needs.

### FEATURES

- 16 Standard Models with Maximum Torque from 2.5 oz·in to 500 lb·in (18 mN·m to 56.5 N·m)
- 14 High Speed Models Available
- Hysteresis Braking System: provides precise torque loading independent of shaft speed
- Motor Testing: from no load to locked rotor
- Standard Torque Units: SI (English & Metric available upon request)
- Accuracy:  $\pm 0.25\%$  (full scale)
- Air Flow Sensor: For protection against overheating and operator error
- Base Plates: available in long or short versions
- Custom Dynamometers: for special torque and speed requirements
- Easy Calibration



Fig. 1: HD-715 | Hysteresis Dynamometer

### DESCRIPTION

Hysteresis Brake Dynamometers (HD Series) are versatile and ideal for testing in the low to medium power range (maximum 14 kW intermittent duty). With a Hysteresis Braking system, the Dynamometers do not require speed to create torque, and therefore can provide a full motor ramp from free-run to locked rotor. Brake cooling is provided by convection (no external source), by compressed air or by dedicated blower, depending on the model. All Magtrol Hysteresis Dynamometers have accuracy ratings of  $\pm 0.25\%$  (full scale) depending on size and system configuration.

To better integrate dynamometers into systems, Magtrol offers both long and short base plates. The shorter base plate facilitates easier motor mounting when used with T-slot tables and Magtrol Adjustable Motor Fixtures, where as the long base plates are better suited for table top testing.

### APPLICATIONS

Magtrol motor test systems can be found in test labs, at inspection stations, and on the manufacturing floors of most of the world's leading manufacturers, users and certifiers of small to medium sized electric, pneumatic and hydraulic motors, as well as internal combustion engines. Magtrol supplies motor test systems for a wide array of industries including: Appliance, Automotive, Aviation, Computer, HVAC, Lawn and Garden, Medical and Dental, Electric Motor, Office Equipment and Power Tools.

## DYNAMOMETER SELECTION

Magtrol's Hysteresis Dynamometers cover a wide range of Torque, Speed and Mechanical Power ratings. To select the appropriate size Dynamometer for your motor testing needs, you will need to determine the **Maximum Torque, Speed and Power** applied to the Dynamometer.

### MAXIMUM TORQUE

The Magtrol Hysteresis Absorption Dynamometer will develop braking torque at any speed point, including low speed and stall conditions ("0" rpm). It is important to consider all torque points that are to be tested, not only rated torque, but also locked rotor and breakdown torque. Dynamometer selection should initially be based on the maximum torque requirement, subject to determining the maximum power requirements.

### MAXIMUM SPEED

This rating is to be considered independent of torque and power requirements, and is the maximum speed at which the Dynamometer can be safely run under free-run or lightly loaded conditions. It is not to be considered as the maximum speed at which full braking torque can be applied.

**To safely dissipate heat and avoid Dynamometer failure, the maximum power rating is the most important consideration in selecting a Dynamometer.**

### MAXIMUM POWER RATINGS

These ratings represent the maximum capability of the Dynamometer Braking System to absorb and dissipate heat generated when applying a braking load to the motor under test. The power absorbed and the heat generated by the Dynamometer is a function of the Torque (**T**) applied to the motor under test, and the resulting Speed (**n**) of the motor. This is expressed in these Power (**P**) formulas:

SI:  $P [W] = T [N \cdot m] \times n [\text{min}^{-1}] \times (1.047 \times 10^{-1})$   
 English:  $P [W] = T [\text{lb} \cdot \text{in}] \times n [\text{rpm}] \times (1.183 \times 10^{-2})$   
 Metric:  $P [W] = T [\text{kg} \cdot \text{cm}] \times n [\text{rpm}] \times (1.027 \times 10^{-2})$

All of Magtrol's controllers, readouts and software calculate horsepower as defined by 1 [hp] = 550 [lb·ft/s].

Using this definition:  $P [\text{hp}] = P [W] / 745.7$

The Dynamometer's ability to dissipate heat is a function of how long a load will be applied. For this reason, the maximum power ratings given are based on continuous operation under load, as well as a maximum of 5 minutes under load.

## OPERATING PRINCIPLES

Magtrol Hysteresis Dynamometers absorb power with a unique Hysteresis Braking System which provides frictionless torque loading independent of shaft speed. The Hysteresis Brake provides torque by the use of two basic components - a reticulated pole structure and a specialty steel rotor/shaft assembly - fitted together but not in physical contact.

Until the pole structure is energized, the drag cup can spin freely on its shaft bearings. When a magnetizing force from the field coil is applied to the pole structure, the air gap becomes a flux field and the rotor is magnetically restrained, providing a braking action between the pole structure and rotor.

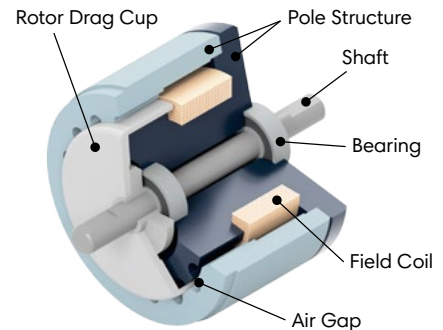

## M-TEST - MOTOR TESTING SOFTWARE

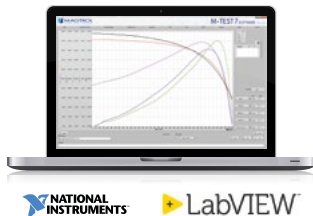

Magtrol's M-TEST Software is a state-of-the-art motor testing program for Windows®-based data acquisition. Used with a Magtrol DSP7010 Dynamometer Controller, Magtrol M-TEST Software provides the control of any Magtrol Dynamometer and

runs test sequences in a manner best suited to the overall accuracy and efficiency of the Magtrol Motor Test System. The data that is generated by Magtrol's Motor Testing Software can be stored, displayed and printed in tabular or graphic formats, and can be easily imported into a spreadsheet.

Written in LabVIEW™, M-TEST has the flexibility to test a majority of motor types in a variety of ways. Because of LabVIEW's versatility, obtaining data from other sources (e.g. thermocouples), controlling motor power and providing audio/visual indicators is relatively easy.

Magtrol's M-TEST Software is ideal for simulating loads, cycling the unit under test and motor ramping. Because it is easy to gather data and duplicate tests, the software is ideal for use in engineering labs. Tests can be programmed to run on their own and saved for future use allowing for valuable time savings in production testing and incoming/outgoing inspection.

SYSTEM CONFIGURATIONS

OPEN LOOP SYSTEMS

Magtrol offers both open loop manual test systems and PC-based closed loop test systems. A typical open loop system will consist of a Dynamometer and a Magtrol DSP 7010 Dynamometer Controller in Open-Loop configuration. A Magtrol Single or Three-Phase Power Analyzer, which allows for the capturing

of volts, amps, watts and power factor, can be included as an option. An open loop system is often used for quick pass/fail testing on the production line or at incoming inspection. Magtrol's DSP 7010 Dynamometer Controller provides pass/fail testing as a standard feature.

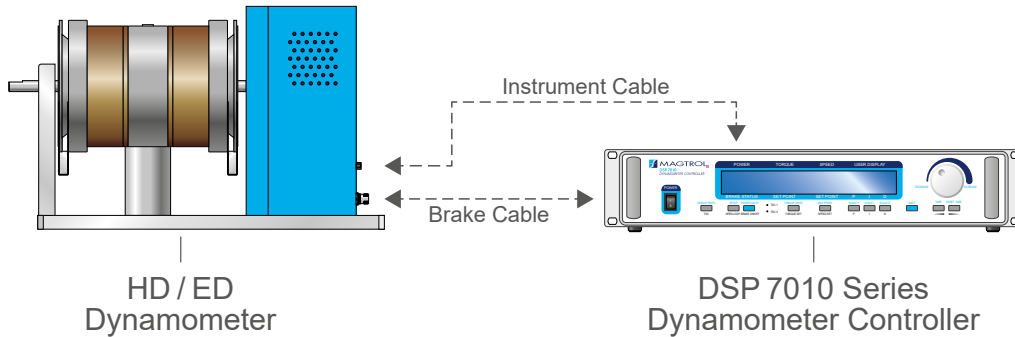

Fig. 2: Dynamometer with DSP 7010 Dynamometer Controller

CLOSED LOOP SYSTEMS

In a closed loop motor test system, data is collected on a PC using Magtrol's M-TEST Software, DSP 7010 Dynamometer Controller, and requisite interface cards and cables. Magtrol's DSP 7010 Dynamometer Controllers compute and display mechanical power (in horsepower or watts) in addition to torque

and speed. A Single or Three Phase Power Analyzer, a required component in a test system measuring motor efficiency, can be integrated into this system as well as Magtrol's Temperature Testing Hardware.

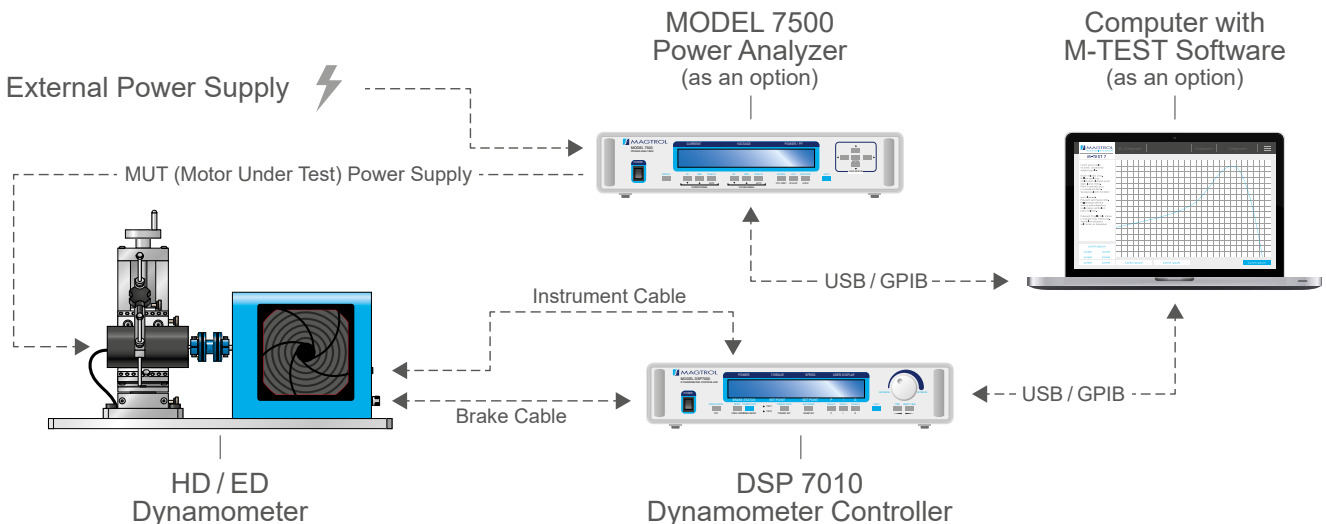

Fig. 3: Dynamometer with MODEL 7500 Power Analyzer, DSP 7010 Dynamometer Controller and M-TEST Software

## SPECIFICATIONS

### HYSTERESIS DYNAMOMETER RATINGS

MODELS	TORQUE MEASURE UNIT CODE <sup>a)</sup>	MAXIMUM TORQUE RANGE	DRAG TORQUE DE-ENERGIZED AT 1000 rpm	NOMINAL INPUT INERTIA		MAX. POWER RATINGS		MAXIMUM SPEED <sup>e)</sup>		BRAKE COOLING METHOD		
				N·m	mN·m	lb·ft·s <sup>2</sup>	kg·m <sup>2</sup>	5 min	CONTINUOUS <sup>b)</sup>		STANDARD	HIGH SPEED
								W	W		rpm	rpm
HD-106	5C	0.018	0.056	4.72 x 10 <sup>-7</sup>	6.35 x 10 <sup>-7</sup>	35	7	30000	50000	Convection		
HD-100	5C	0.08	0.64	3.40 x 10 <sup>-6</sup>	4.61 x 10 <sup>-6</sup>	75	20	25000	40000	Convection		
HD-400	5C	0.28	2	1.55 x 10 <sup>-5</sup>	2.10 x 10 <sup>-5</sup>	200	55			Convection		
HD-500	5C	0.85	5	8.05 x 10 <sup>-5</sup>	1.09 x 10 <sup>-4</sup>	400	80			Convection		
HD-510	5C			8.05 x 10 <sup>-5</sup>	1.09 x 10 <sup>-4</sup>	750	375			Compressed Air <sup>c)</sup> (7CFM @ 1.75PSI)		
HD-505	5C	1.7	10	1.61 x 10 <sup>-4</sup>	2.18 x 10 <sup>-4</sup>	800	160			Convection		
HD-515	5C			1.61 x 10 <sup>-4</sup>	2.18 x 10 <sup>-4</sup>	1500	900			Compressed Air <sup>c)</sup> (10CFM @ 4 PSI)		
HD-700	5C	3.1	13	5.51 x 10 <sup>-4</sup>	7.47 x 10 <sup>-4</sup>	700	150			35000	Convection	
HD-710	5C			5.51 x 10 <sup>-4</sup>	7.47 x 10 <sup>-4</sup>	1500	935				Blower <sup>d)</sup>	
HD-705	5C	6.2	23	1.10 x 10 <sup>-3</sup>	1.49 x 10 <sup>-3</sup>	1400	300			Convection		
HD-715	5C			1.10 x 10 <sup>-3</sup>	1.49 x 10 <sup>-3</sup>	3400	3000			Blower <sup>d)</sup>		
HD-800	5C	14.0	100	4.43 x 10 <sup>-3</sup>	6.01 x 10 <sup>-3</sup>	2800	1800	12000	N/A	Compressed Air <sup>c)</sup> (13CFM @ 10PSI)		
HD-810	5C			4.43 x 10 <sup>-3</sup>	6.01 x 10 <sup>-3</sup>	3500	3000		15000	Blower <sup>d)</sup>		
HD-805	5C	28.0	140	8.81 x 10 <sup>-3</sup>	1.19 x 10 <sup>-2</sup>	5300	2250	15000	N/A	Compressed Air <sup>c)</sup> (15CFM @ 14PSI)		
HD-815	5C			8.81 x 10 <sup>-3</sup>	1.19 x 10 <sup>-2</sup>	7000	6000		Blower <sup>d)</sup>			
HD-825	5C	56.5	400	1.85 x 10 <sup>-2</sup>	2.51 x 10 <sup>-2</sup>	14000	12000	8000	10000	Blower <sup>d)</sup>		

a) All -5C dynamometers are 5 Volt Output. Please, contact our sales representative for 6C (English units), 7C (Metric units) or 8C (SI units) specifications.

b) Operating at the continuous power rating for periods of up to 4 hours is acceptable. However, operating for extended periods at high temperatures will result in premature component and bearing failure. Limiting the length of the cycle and the component temperatures will guard against premature failure. Where continuous duty is desired for longer time intervals, component temperatures should be maintained less than 100°C; monitoring the outside brake surface temperature is a sufficient reference.

c) Requires air cooling provided by user. Regulator and filter package is provided as standard

d) Blower is included

e) The maximum speed will depend on what type of keyway (if any) is used on the shaft. Unless specified, the dynamometer shaft will be made without a keyway.

### ELECTRICAL POWER

MODELS	VOLTAGE	VA
HD-1XX-5C1, HD-4XX-5C1, HD-5XX-5C1	120V	30
HD-1XX-5C2, HD-4XX-5C2, HD-5XX-5C2	240V	
HD-800-5C1, HD-810-5C1	120V	65
HD-800-5C2, HD-810-5C2	240V	
HD-805-5C1, HD-815-5C1	120V	130
HD-805-5C2, HD-815-5C2	240V	
HD-825-5C1	120V	N/A
HD-825-5C2	240V	

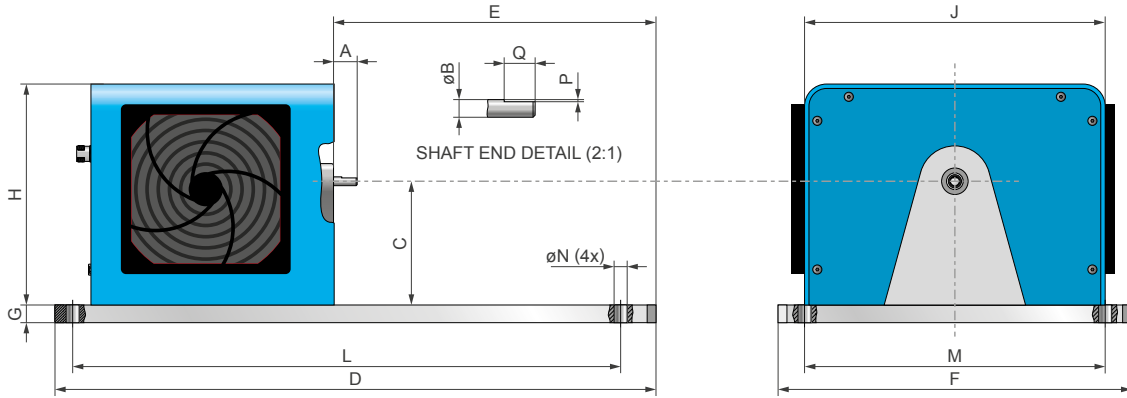
**DIMENSIONS HD-100 / 400 / 500**
**HD-100 / 400 / 500 SERIES WITH LONG BASE PLATE**

NOTE: Original dimensions are in English units. Dimensions converted to Metric units have been rounded and are for reference only.

MODELS	units	A	ØB	C	D	E	F	G	H	J	L <sup>a)</sup>	M <sup>a)</sup>	ØN	P	Q	Weight
HD-106	in	0.50	0.1245 0.1247	3.5	17	9.38	10	0.5	6.3	8.5	15.5	8.5	0.37	0.015	0.375	12.0 lb
	mm	12.7	3.162 3.167	88.9	432	238.3	254	12.7	159	216	394	216	9.4	0.38	9.53	5.4 kg
HD-100	in	0.75	0.1870 0.1872	3.5	17	9.13	10	0.5	6.3	8.5	15.5	8.5	0.37	0.025	0.375	12.5 lb
	mm	19.1	4.750 4.755	88.9	432	231.9	254	12.7	159	216	394	216	9.4	0.64	9.53	5.7 kg
HD-400	in	0.67	0.2495 0.2497	3.5	17	9.13	10	0.5	6.3	8.5	15.5	8.5	0.37	0.03	0.438	15.0 lb
	mm	17.0	6.337 6.342	88.9	432	231.9	254	12.7	159	216	394	216	9.4	0.76	11.13	6.8 kg
HD-500	in	0.88	0.3745 0.3750	4.0	17	9.13	10	0.5	6.3	8.5	15.5	8.5	0.37	0.047	0.375	16.0 lb
	mm	22.2	9.512 9.525	101.6	432	231.9	254	12.7	159	216	394	216	9.4	1.19	9.53	7.3 kg
HD-510	in	0.88	0.3745 0.3750	4.0	17	9.13	10	0.5	6.3	8.5	15.5	8.5	0.37	N/A <sup>b)</sup>		16.0 lb
	mm	22.2	9.512 9.525	101.6	432	231.9	254	12.7	159	216	394	216	9.4	N/A <sup>b)</sup>		7.3 kg
HD-505	in	0.88	0.3745 0.3750	4.0	20	9.64	10	0.5	6.3	8.5	18.5	8.5	0.37	0.05	0.375	18.0 lb
	mm	22.2	9.512 9.525	101.6	508	244.9	254	12.7	159	216	470	216	9.4	1.27	9.53	8.1 kg
HD-515	in	0.88	0.3745 0.3750	4.0	20	9.64	10	0.5	6.3	8.5	18.5	8.5	0.37	N/A <sup>b)</sup>		18.0 lb
	mm	22.2	9.512 9.525	101.6	508	244.9	254	12.7	159	216	470	216	9.4	N/A <sup>b)</sup>		8.1 kg

a) These dimensions represent the distance between mounting holes. There are four (4) mounting holes on each base plate.

b) Shaft Flats are not available on high speed models.

NOTE: 3D STEP files of most of our products are available on our website: [www.magtrol.com](http://www.magtrol.com) ; other files are available on request.

DIMENSIONS HD-100 / 400 / 500

HD-100 / 400 / 500 SERIES WITH SHORT BASE PLATE

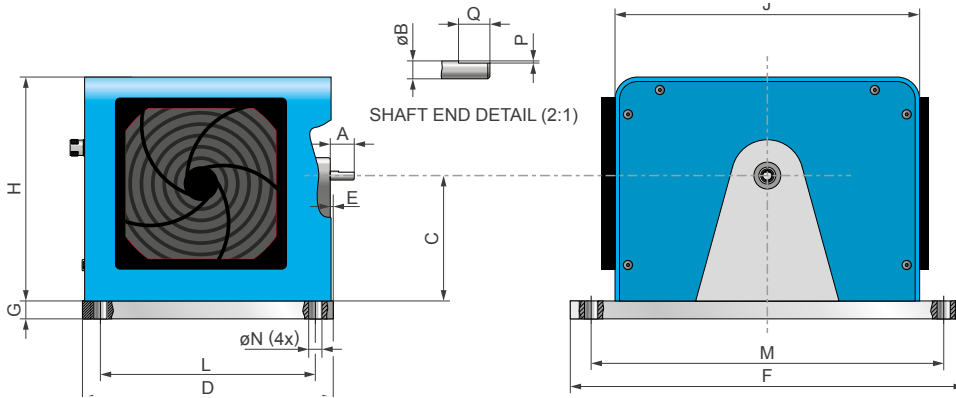

Fig. 4: HD-400 Dynamometer with short base plate

NOTE: Original dimensions are in English units. Dimensions converted to Metric units have been rounded and are for reference only.

MODELS	units	A	ØB	C	D	E	F	G	H	J	L <sup>a)</sup>	M <sup>a)</sup>	Ø N	P	Q	Weight
HD-106	in	0.50	0.1245 0.1247	3.5	7.0	0.33	11	0.5	6.3	8.5	6.0	9.84	0.35	0.015	0.375	7.5 lb
	mm	12.7	3.162 3.167	88.9	177.8	8.4	279.4	12.7	159	216	152.4	250	9	0.38	9.53	3.4 kg
HD-100	in	0.75	0.1870 0.1872	3.5	7.0	0.08	11	0.5	6.3	8.5	6.0	9.84	0.35	0.025	0.375	8.0 lb
	mm	19.1	4.750 4.755	88.9	177.8	2.1	279.4	12.7	159	216	152.4	250	9	0.64	9.53	3.6 kg
HD-400	in	0.67	0.2495 0.2497	3.5	7.0	0.08	11	0.5	6.3	8.5	6.0	9.84	0.35	0.03	0.438	11.0 lb
	mm	17.0	6.337 6.342	88.9	177.8	2.1	279.4	12.7	159	216	152.4	250	9	0.76	11.13	5.0 kg
HD-500	in	0.88	0.3745 0.3750	4.0	7.0	0.08	11	0.5	6.3	8.5	6.0	9.84	0.35	0.047	0.375	12.0 lb
	mm	22.2	9.512 9.525	101.6	177.8	2.1	279.4	12.7	159	216	152.4	250	9	1.19	9.53	5.4 kg
HD-510	in	0.88	0.3745 0.3750	4.0	8.0	0.13	11	0.5	6.3	8.5	7.0	9.84	0.35	N/A <sup>b)</sup>		12.5 lb
	mm	22.2	9.512 9.525	101.6	203.2	3.2	279.4	12.7	159	216	177.8	250	9	N/A <sup>b)</sup>		5.7 kg
HD-505	in	0.88	0.3745 0.3750	4.0	9.5	0.10	11	0.5	6.3	8.5	8.5	9.84	0.35	0.05	0.375	13.0 lb
	mm	22.2	9.512 9.525	101.6	241.3	2.6	279.4	12.7	159	216	215.9	250	9	1.27	9.53	5.9 kg
HD-515	in	0.88	0.3745 0.3750	4.0	10.25	0.10	11	0.5	6.3	8.5	9.25	9.84	0.35	N/A <sup>b)</sup>		13.0 lb
	mm	22.2	9.512 9.525	101.6	260.4	2.6	279.4	12.7	159	216	234.9	250	9	N/A <sup>b)</sup>		5.9 kg

a) These dimensions represent the distance between mounting holes. There are four (4) mounting holes on each base plate.

b) Shaft Flats are not available on high speed models.

NOTE: 3D STEP files of most of our products are available on our website: [www.magtrol.com](http://www.magtrol.com) ; other files are available on request.

DIMENSIONS HD-700

HD-700 SERIES WITH LONG BASE PLATE

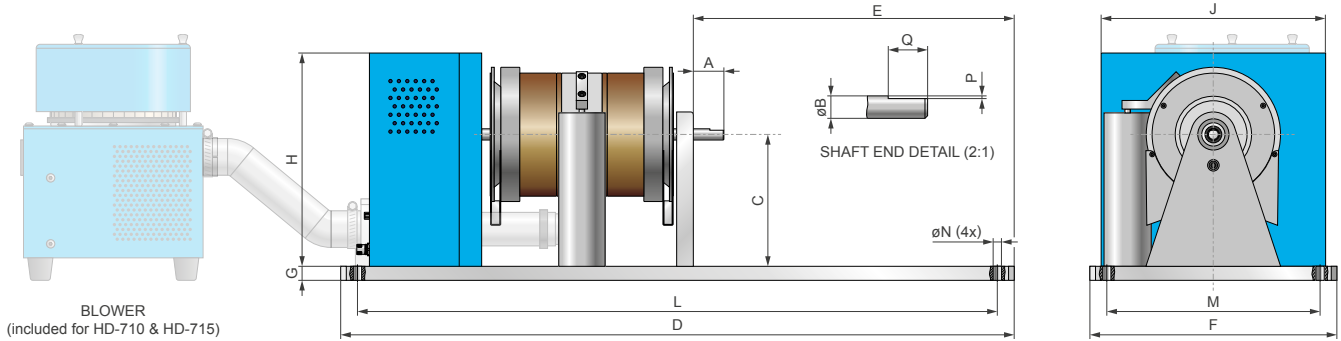

HD-700 SERIES WITH SHORT BASE PLATE

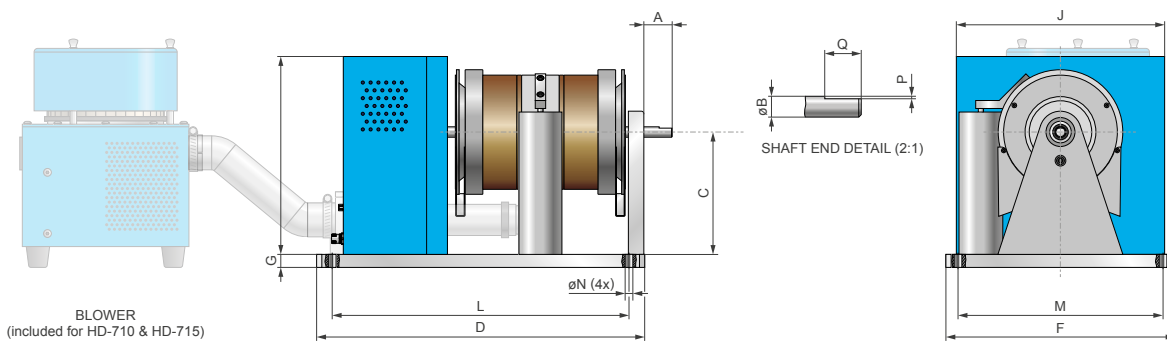

NOTE: Original dimensions are in English units. Dimensions converted to Metric units have been rounded and are for reference only.

MODELS	units	A	øB	C	D	E	F	G	H	J	L <sup>a)</sup>	M <sup>a)</sup>	øN	P	Q	Weight
<b>HD-700 SERIES WITH LONG BASE PLATE</b>																
HD-700	in	1.25	0.4995/0.4999	5.875	24	12.75	11	0.625	9.5	10	22.5	9.5	0.375	0.06	0.63	39 lb
	mm	31.8	12.687/12.692	149.2	609.6	323.9	279.4	15.9	241.3	254	571.5	241.3	9.5	1.6	15.9	17.6 kg
HD-710	in	1.25	0.4995/0.4999	5.875	26	13.59	11	0.625	9.5	10	24.5	9.5	0.375	N/A <sup>b)</sup>		45 lb
	mm	31.8	12.687/12.692	149.2	660.4	345.2	279.4	15.9	241.3	254	622.3	241.3	9.5	N/A <sup>b)</sup>		20.3 kg
HD-705	in	1.25	0.4995/0.4999	5.875	28	13.62	11	0.625	9.5	10	26.5	9.5	0.375	0.06	0.63	52 lb
	mm	31.8	12.687/12.692	149.2	711.2	346.0	279.4	15.9	241.3	254	673.1	241.3	9.5	1.6	15.9	23.5 kg
HD-715	in	1.25	0.4995/0.4999	5.875	30	14.29	11	0.625	9.5	10	28.5	9.5	0.375	N/A <sup>b)</sup>		59 lb
	mm	31.8	12.687/12.692	149.2	762.0	363.0	279.4	15.9	241.3	254	723.9	241.3	9.5	N/A <sup>b)</sup>		26.6 kg
<b>HD-700 SERIES WITH SHORT BASE PLATE</b>																
HD-700	in	1.25	0.4995/0.4999	5.875	11.34	0.09	11	0.625	9.5	10	9.84	9.84	0.375	0.06	0.63	30 lb
	mm	31.8	12.687/12.692	149.2	288.0	2.2	279.4	15.9	241.3	254	250.0	250	9.5	1.6	15.9	13.6 kg
HD-710	in	1.25	0.4995/0.4999	5.875	12.50	0.09	11	0.625	9.5	10	11.00	9.84	0.375	N/A <sup>b)</sup>		36 lb
	mm	31.8	12.687/12.692	149.2	317.5	2.2	279.4	15.9	241.3	254	279.5	250	9.5	N/A <sup>b)</sup>		16.3 kg
HD-705	in	1.25	0.4995/0.4999	5.875	14.45	0.09	11	0.625	9.5	10	12.95	9.84	0.375	0.06	0.63	43 lb
	mm	31.8	12.687/12.692	149.2	367.0	2.2	279.4	15.9	241.3	254	329.0	250	9.5	1.6	15.9	19.5 kg
HD-715	in	1.25	0.4995/0.4999	5.875	15.75	0.09	11	0.625	9.5	10	14.25	9.84	0.375	N/A <sup>b)</sup>		50 lb
	mm	31.8	12.687/12.692	149.2	400.0	2.2	279.4	15.9	241.3	254	362.0	250	9.5	N/A <sup>b)</sup>		22.7 kg

a) These dimensions represent the distance between mounting holes. There are four (4) mounting holes on each base plate.

b) Shaft Flats are not available on high speed models.

NOTE: 3D STEP files of most of our products are available on our website: [www.magtrol.com](http://www.magtrol.com) ; other files are available on request.



DIMENSIONS HD-800

HD-800 SERIES WITH LONG BASE PLATE

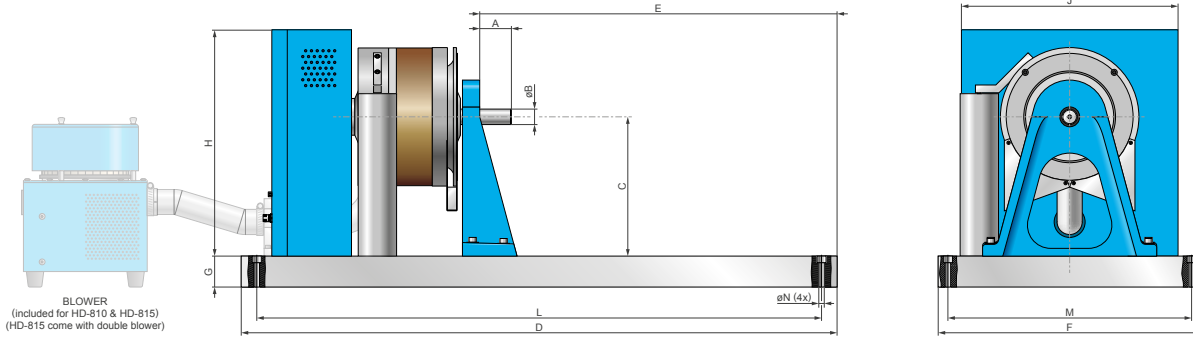

HD-800 SERIES WITH SHORT BASE PLATES

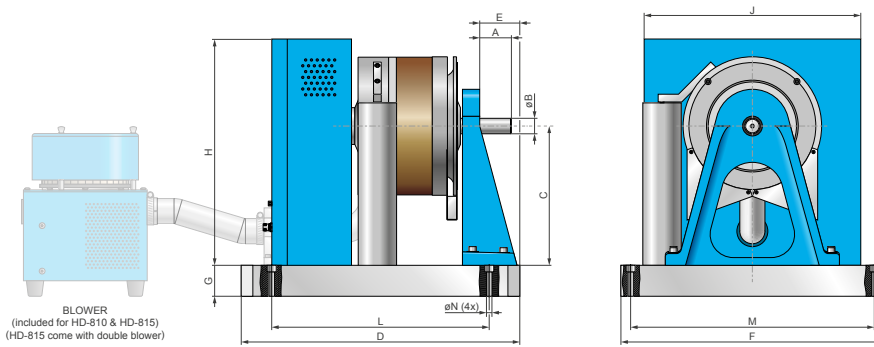

Fig. 5: HD-810 Dynamometer with short base plate and blower

NOTE: For detailed dimension drawings of dynamometers with the T-slot base plate option, visit Magtrol's Web site.

NOTE: Original dimensions are in English units. Dimensions converted to Metric units have been rounded and are for reference only.

MODEL	units	A	øB	C	D	E	F	G	H	J	L <sup>a)</sup>	M <sup>a)</sup>	øN	Weight
<b>HD-800 SERIES WITH LONG BASE PLATE</b>														
HD-800	in	2.13	0.9995/1.0000	9	38.5	23.81	17	2	14.6	14	36.5	15	0.53	237.0 lb
	mm	54	25.387/25.400	228.6	978	605	432	50.8	371	356	927	381	13.5	107.2 kg
HD-810	in	2.05	0.9995/1.0000	9	38.5	23.09	17	2	14.6	14	36.5	15	0.53	233.0 lb
	mm	52	25.387/25.400	228.6	978	587	432	50.8	371	356	927	381	13.5	105.3 kg
HD-805	in	2.13	0.9995/1.0000	9	38.5	20.57	17	2	14.6	14	36.5	15	0.54	287.0 lb
	mm	54	25.387/25.400	228.6	978	522	432	50.8	371	356	927	381	13.7	129.7 kg
HD-815	in	2.12	0.9995/1.0000	9	38.5	18.19	17	2	14.6	14	36.5	15	0.54	288.0 lb
	mm	54	25.387/25.400	228.6	978	462	432	50.8	371	356	927	381	13.7	130.1 kg
<b>HD-800 SERIES WITH SHORT BASE PLATE</b>														
HD-800	in	2.13	0.9995/1.0000	9	17.25	2.56	17	2	14.6	14	13.78	15.75	0.35	168.0 lb
	mm	54	25.387/25.400	228.6	438	65	432	50.8	371	356	350	400	9	76.2 kg
HD-810	in	2.05	0.9995/1.0000	9	18.00	2.59	17	2	14.6	14	14.06	15.75	0.35	164.0 lb
	mm	52	25.387/25.400	228.6	457	66	432	50.8	371	356	357	400	9	74.4 kg
HD-805	in	2.13	0.9995/1.0000	9	20.50	2.57	17	2	14.6	14	15.75	15.75	0.35	228.0 lb
	mm	54	25.387/25.400	228.6	520	65	432	50.8	371	356	400	400	9	103.4 kg
HD-815	in	2.12	0.9995/1.0000	9	23.00	2.59	17	2	14.6	14	19.09	15.75	0.35	236.0 lb
	mm	54	25.387/25.400	228.6	584	66	432	50.8	371	356	485	400	9	107.0 kg

a) These dimensions represent the distance between mounting holes. There are four (4) mounting holes on each base plate.

NOTE: 3D STEP files of most of our products are available on our website: [www.magtrol.com](http://www.magtrol.com) ; other files are available on request.



**DIMENSIONS HD-825**

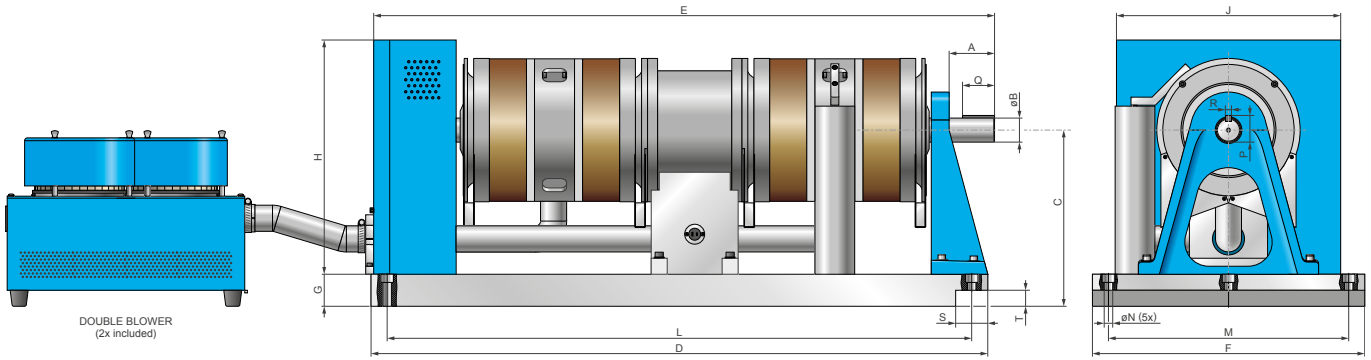

An HD-825 Dynamometer with long base plate is available if ordered with the accompanying dynamometer table (TAB 0825L). Contact Magtrol for details.

MODEL	units	A	øB	C	D	E	F	G	H	J	L <sup>a)</sup>	M <sup>a)</sup>	øN	P	Q	R	S	T	Weight
HD-825	in	2.83	1.4995 1.5000	11	38.5	38.93	17	2	16.6	14	36.5	15	0.54	1.287	2	0.376	2	1	400.0 lb
	mm	72	38.087 38.100	279.4	978	989	432	50.8	422	356	927	381	13.7	32.69	50.8	9.53	50.8	25.4	181.4 kg

a) These dimensions represent the distance between mounting holes. There are four (4) mounting holes on each base plate.

**BLOWERS**

**BLOWER POWER**

MODEL	VOLTAGE	VA	MODEL	VOLTAGE	VA
BL-001	120 V	600	BL-002	120 V	1000
BL-001A	240 V	500	BL-002A	240 V	

- Models HD-710, HD-715 & HD-810 include the BL-001 blower.
- Models HD-815 include the BL-002 blower.
- Model HD-825 uses two BL-002 blowers for cooling its two brake sets.

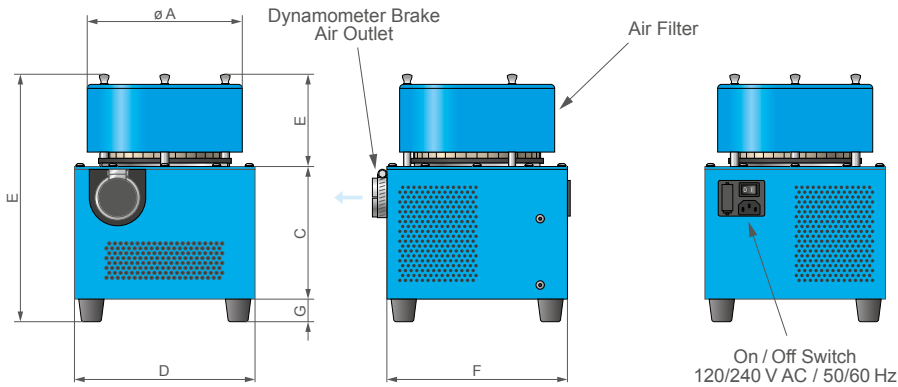

Allow approximately 6 in to 8 in (152 mm to 203 mm) between rear of dynamometer base plate and blower for connection hardware. Required hardware is supplied with the dynamometer.

BL-002 Blower has two filter elements.

MODEL	units	øA	B	C	D	E	F	G	Weight
BL-001	mm	178	279	254	203	102	203	25	3.9 kg
	in	7	11	10	8	4	8	1	8.5 lb
BL-002	mm	178	279	254	381	102	308	25	8.1 kg
	in	7	11	10	15	4	12	1	18 lb

**NOTE:** 3D STEP files of most of our products are available on our website: [www.magtrol.com](http://www.magtrol.com) ; other files are available on request.

POWER ABSORPTION CURVES

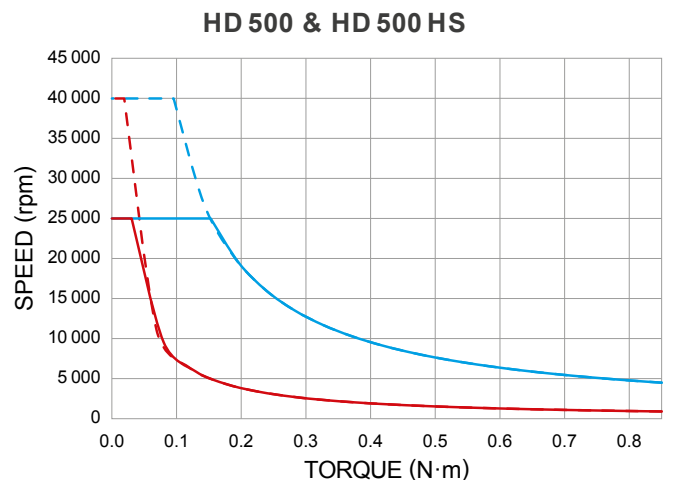
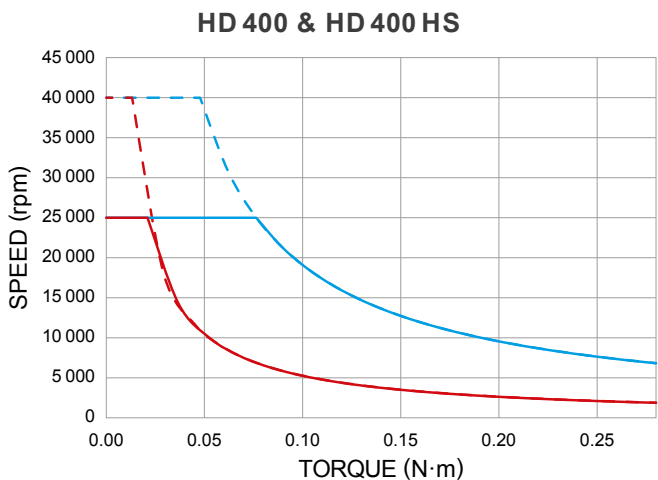
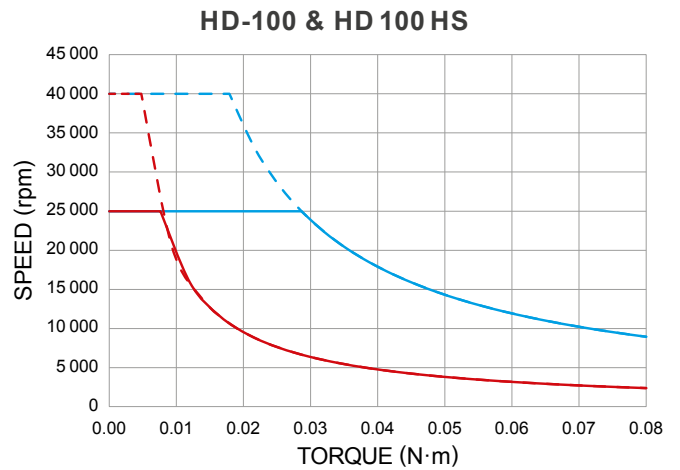
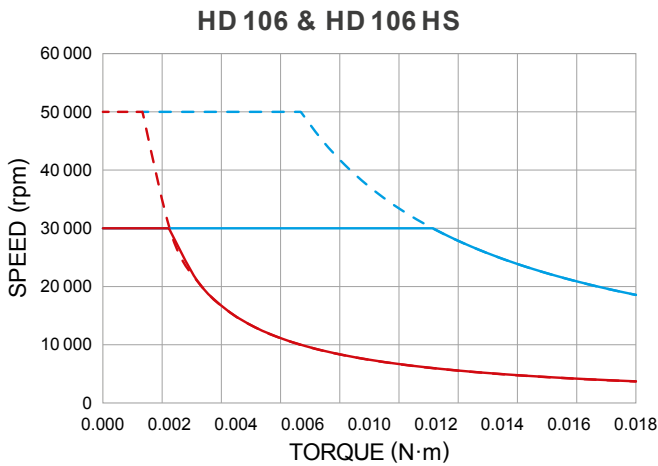
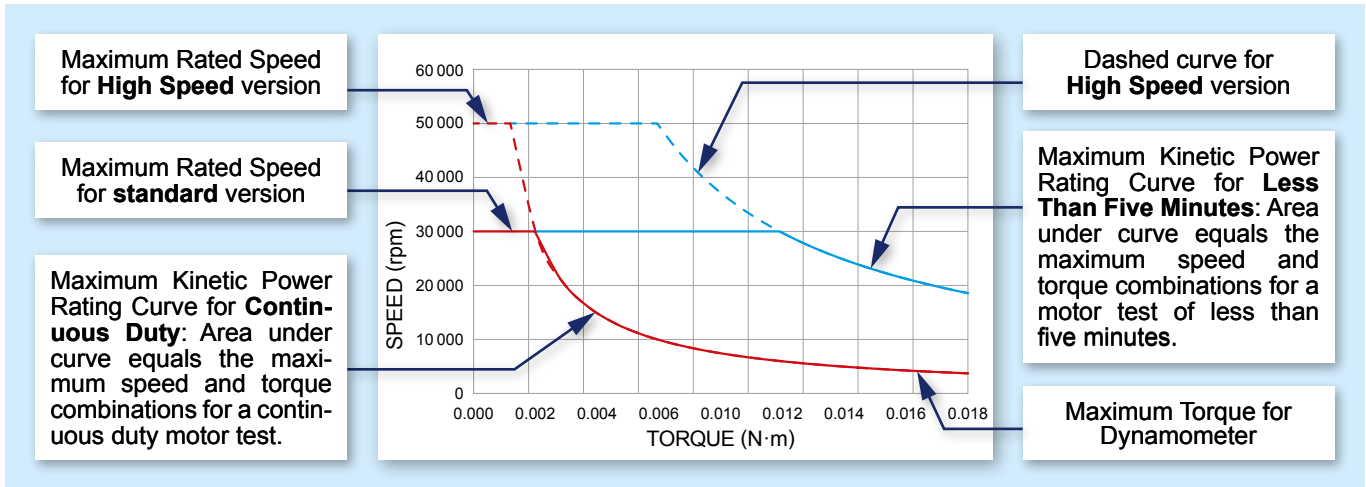

The power absorption curves represent the maximum power (heat) that the dynamometer can dissipate over time.

POWER ABSORPTION CURVES

HD 510 & HD 510 HS

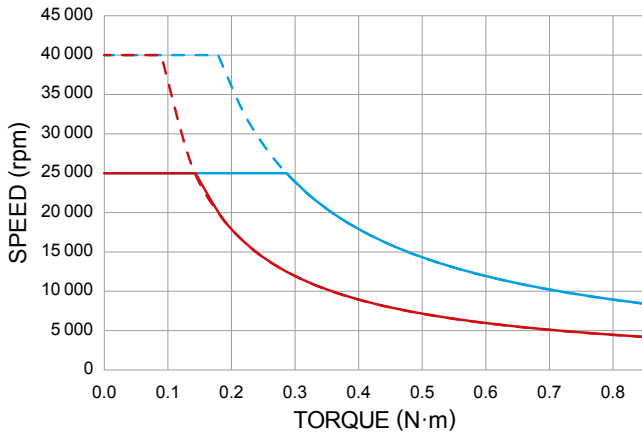

HD 505 & HD 505 HS

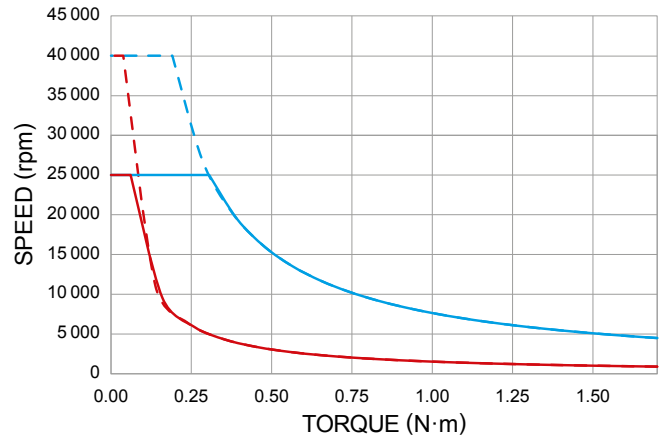

HD 515 & HD 515 HS

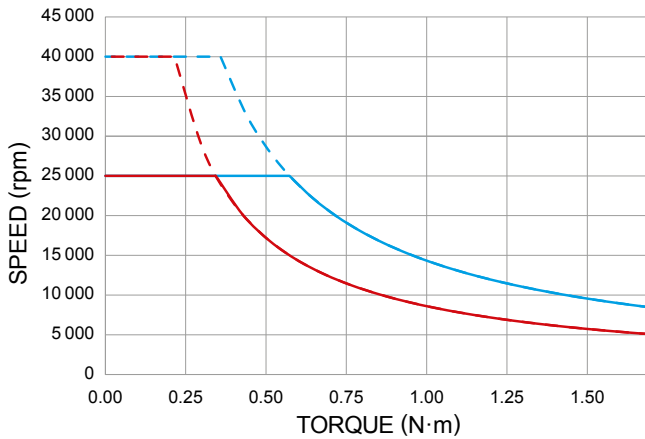

HD 700 & HD 700 HS

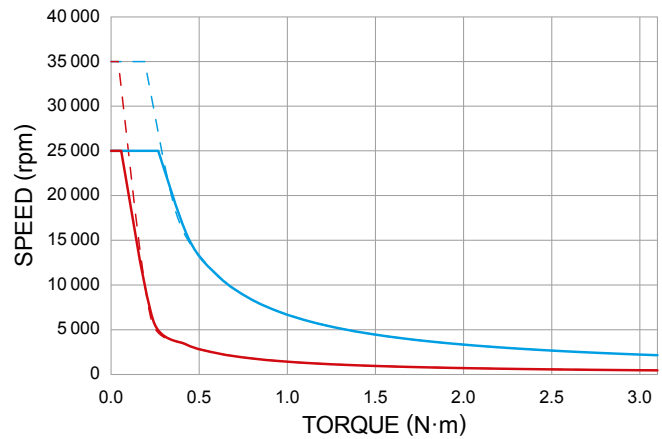

HD 710 & HD 710 HS

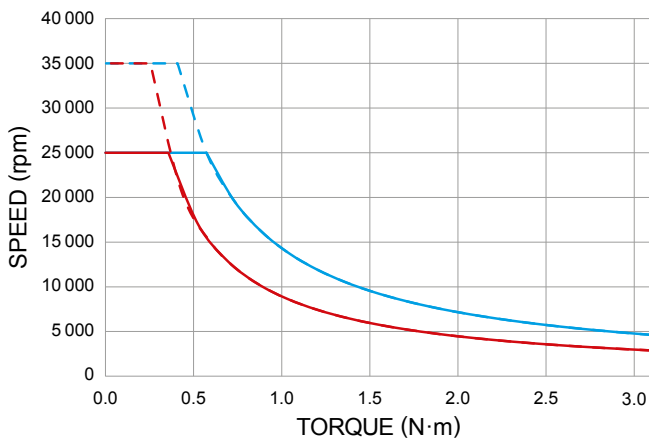

HD 705 & HD 705 HS

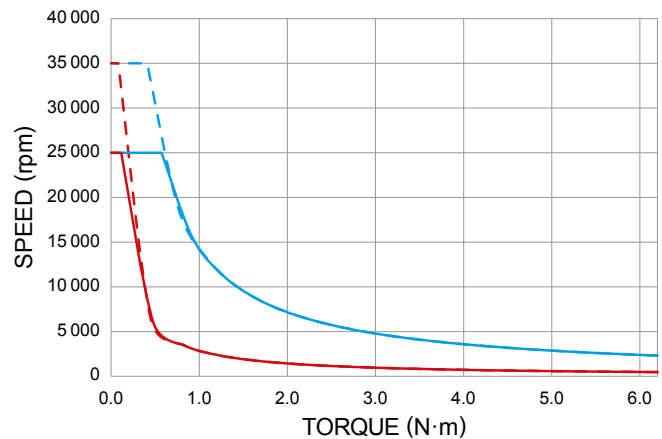

The power absorption curves represent the maximum power (heat) that the dynamometer can dissipate over time.

**POWER ABSORPTION CURVES**

**HD 715 & HD 715 HS**

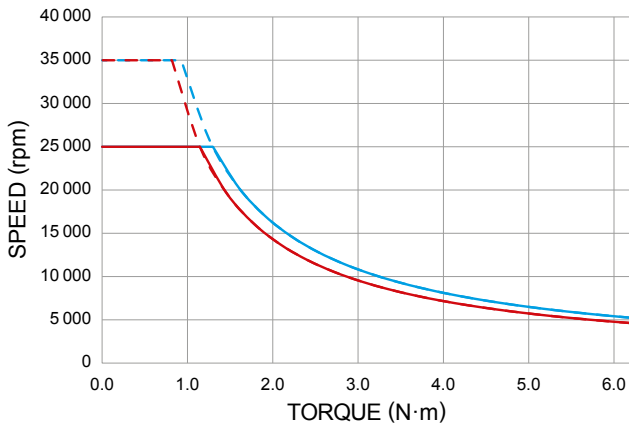

**HD 800**

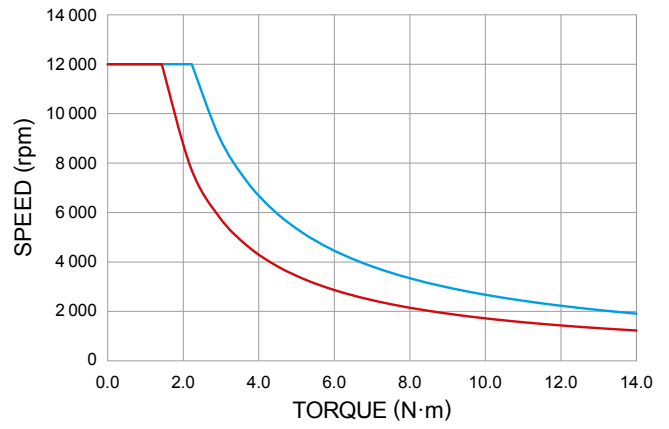

**HD 805**

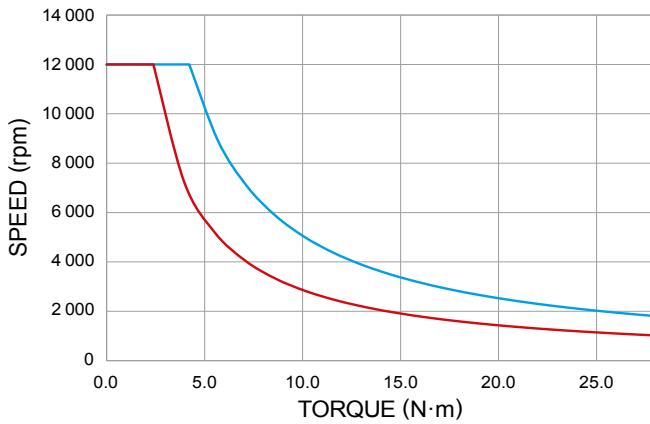

**HD 810 & HD 810 HS**

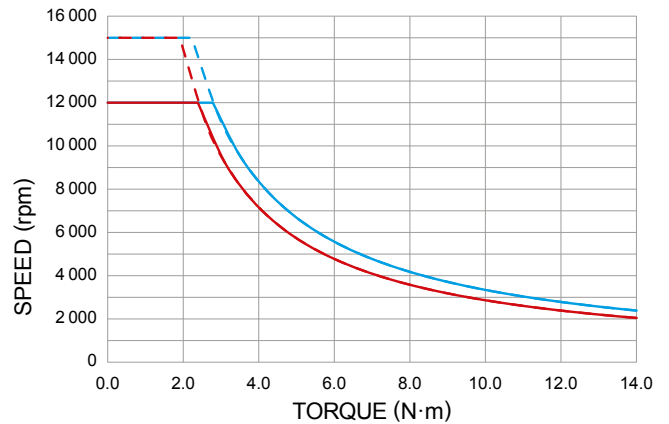

**HD 815 & HD 815 HS**

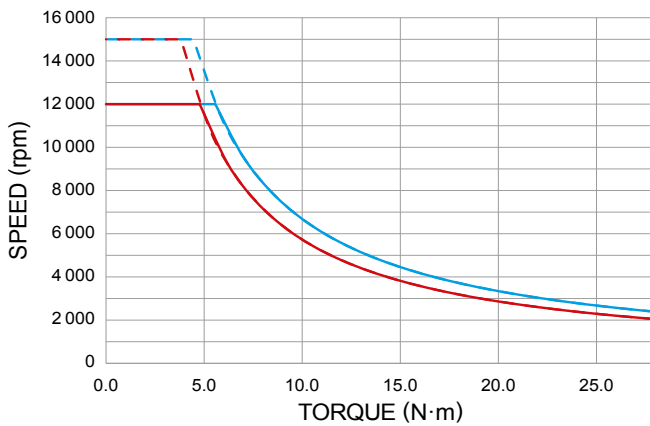

**HD 825 & HD 825 HS**

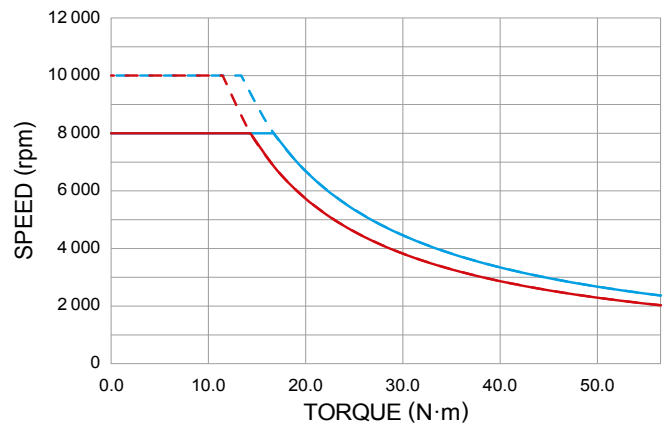

The power absorption curves represent the maximum power (heat) that the dynamometer can dissipate over time.

## CUSTOM MOTOR TEST SYSTEM

HD Series Hysteresis Dynamometers can be incorporated into a Customized Motor Test System (CMTS).

These PC based, turn-key systems are custom designed and built to meet specific user requirements.

Various devices such as dynamometer controllers, power analyzers or other customized devices can be easily integrated into a 19" rack system (in an external cabinet or directly in the table).

These systems integrate specific software (such as M-TEST) to facilitate the measurement process.

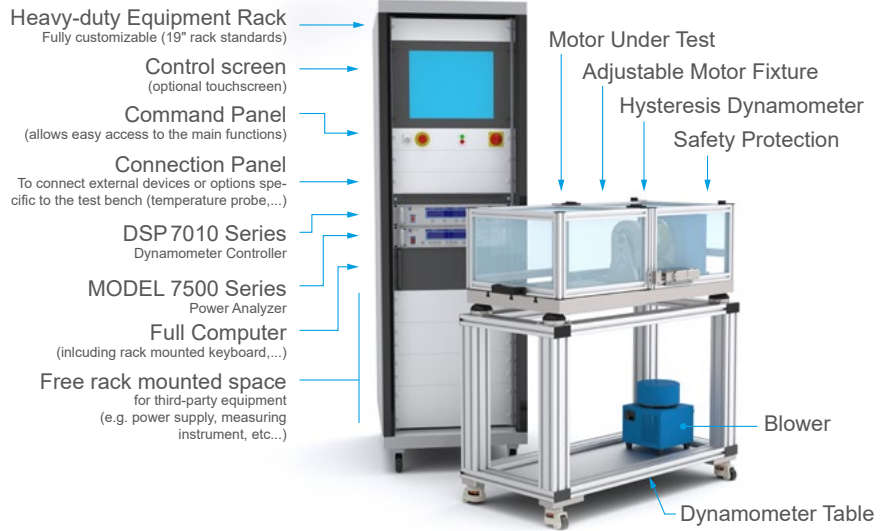

## DYNAMOMETER OPTIONS

### ENCODER OPTIONS FOR LOW SPEED TESTING

For low speed motors, such as gear motors with maximum speeds of less than 200 rpm, Magtrol offers additional encoder options that allow for increased resolution of the speed signal.

### T-SLOT BASE PLATE

To accommodate Magtrol AMF-3 Adjustable Motor Fixtures, a grooved base plate with three M12 T-slots, one centered and two 250 mm apart, is available on all HD-8XX series dynamometers.

### MECHANICAL CUSTOMISATIONS

Magtrol is highly experienced and qualified in the customization of its products. We can provide customized base plates, riser blocks and shaft modifications. Our specialized salesmen and technicians are at your service to help you find the best configuration for your project.



## ORDERING INFORMATION

MODEL NUMBER	HD-	---	- 5C	-	- 0 <sup>a)</sup>	-	-	-
<b>100-825</b> : Hysteresis Dynamometers								
<b>0</b> : AC power not applicable								
<b>1</b> : 120 VAC								
<b>2</b> : 240 VAC								
<b>0</b> : Long base plate <sup>b)</sup>								
<b>1</b> : Short base plate								
<b>2</b> : Long base with T-slots (HD-8XX Series only)								
<b>0</b> : 60 PPR speed encoder (standard & HS) <sup>c)</sup>								
<b>3</b> : 60 + 600 PPR speed encoder <sup>c)</sup>								
<b>4</b> : 60 + 6000 PPR speed encoder <sup>c)</sup>								
<b>0</b> : Standard version								
<b>H</b> : High Speed (not available on HD-800 & HD-805)								

- a) In case of special design the 4 last digits will be specific; please contact our sales representative
- b) Please contact our sales representative regarding long base plate
- c) PPR means Pulse Per Revolution

Example: HD Series Dynamometer, model 106, supply in 240 VAC, short base plate, 60-PPR encoder and standard version would be ordered as follows: **HD-106-5C2-0100**

HD Series Dynamometer, model 805, supply in 120 VAC, long base plate with T-slot, 6000-PPR encoder and high speed version would be ordered as follows: **HD-805-5C1-024H**

### CABLE ASSEMBLY

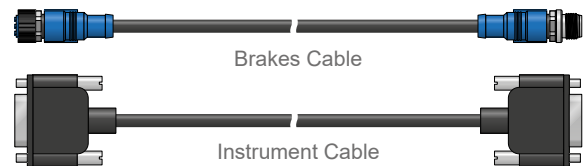

ORDERING NUMBER	88M	-	-	-
<b>367</b> : Brake Cable				
<b>368</b> : Instrument Cable				
<b>0150</b> : Cable length 1.5 m <sup>a)</sup>				
<b>0500</b> : Cable length 5 m <sup>a)</sup>				

a) Other length available on request

## SYSTEM OPTIONS AND ACCESSORIES

### DSP 7010 - DYNAMOMETER CONTROLLERS

Magtrol's MODEL DSP7010 Series Dynamometer Controller employs state-of-the-art Digital Signal Processing Technology to provide superior motor testing capabilities. Designed for use with any Magtrol Hysteresis, Eddy-Current or Powder Dynamometer, Magtrol In-Line Torque Transducer or auxiliary instrumentation, the DSP7010 can provide complete PC control via the USB or IEEE-488 interface. With up to 500 readings per second, the DSP7010 is ideally suited for both the test lab and the production line.



Fig. 7: DSP 7011 | Programmable Dynamometer Controllers

### MODEL 7500 - POWER ANALYZERS

The Magtrol MODEL 7500 Power Analyzer is an easy-to-use instrument ideal for numerous power measurement applications. From DC to 80kHz, the MODEL 7500 measures volts, amps, watts, volt-amps, frequency, crest factor, Vpeak, Apeak and power factor in one convenient display. They may be used either as stand-alone instruments or in conjunction with any Magtrol Hysteresis, Eddy-Current or Powder Brake Dynamometer; any Magtrol Dynamometer Controller and M-TEST Software for more demanding motor test applications.



Fig. 9: MODEL 7510 | Power Analyzers

### WB & PB SERIES - DYNAMOMETER



Fig. 8: 1PB 115 | Powder Dynamometer

The WB Series (eddy current) and PB Series (magnetic powder) dynamometers are particularly suitable for demanding applications requiring low (PB) to high (WB up to 65000 rpm) speeds. The PB brakes will develop their nominal torque at standstill, while the WB

brakes develop a braking torque proportional to the speed and their maximum torque is reached at nominal speed. The brake is cooled by water circulating in the stator. As a result, these dynamometers are able to dissipate high continuous loads (up to 140kW). The WB and PB dynamometers incorporate a torque measuring system which has an accuracy of  $\pm 0.3\%$  to  $\pm 0.5\%$  at full scale.

### TAB SERIES - DYNAMOMETER TABLES

Test from a stationary position or move a dynamometer to alternate testing stations with ease with Magtrol's Dynamometer Table. The stand is designed from lightweight aluminum with casters for smooth mobility, and is sturdy enough to support even the heaviest of Magtrol dynamometers. The design can be retrofitted to any Magtrol dynamometer and is easily reconfigured for added versatility.

### AMF SERIES - MOTOR FIXTURES

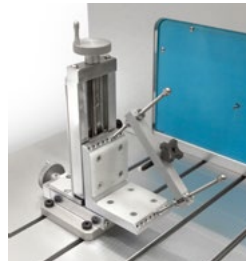

Positioning and alignment have a great influence on the measured parameters (friction torque). MAGTROL strongly recommends a support specifically dedicated to the products to be tested to ensure the best positioning tolerances in X-Y, and its repeatability.

Alternatively, Magtrol AMF Series (Adjustable Motor Fixtures) can be used. These extremely versatile fixtures can accommodate motors up to 101 mm (4") in diameter. It enables easy motor centering during testing, but does not have centering references.



Fig. 10: TAB Series | Dynamometer Tables