

Control Unit from 1 to 4 Conventional sensors BX444-Mc

Rev. 6

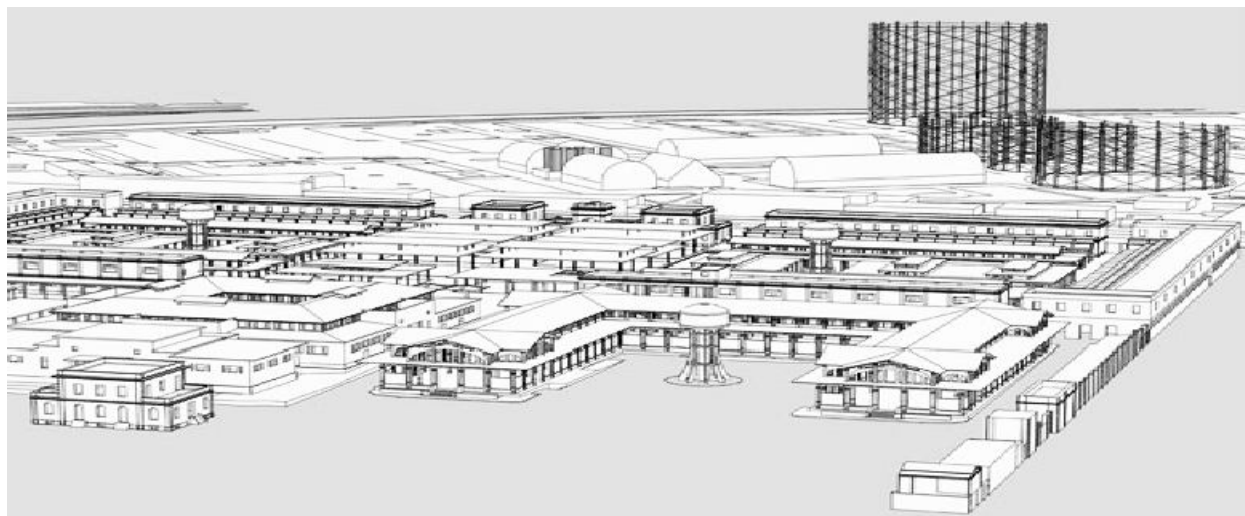

The **BX444-Mc** control unit has been designed and built according to European regulations to flexibly detect the presence of **toxic and/or explosive gas and OXYGEN**, through the connection of 4 remote probes. A microprocessor is used to create a complete surveillance and control system with maximum flexibility. Thanks to this and its other features **BX444-Mc** is suitable for civil use, industrial use and small underground car parks.

The **BX444-M** control unit has three danger levels:

1st LEVEL, 1st Alarm. This was set to 8 % of L.E.L. (120ppm)

2nd LEVEL, 2nd Alarm. This was set at 13% of L.E.L. (200ppm)

3rd LEVEL, Main Alarm. This was set at 20 % of L.E.L. (300ppm)

For oxygen the control unit **BX444-Mc** presents three levels of danger which are:

1st Pre-Alarm. Both in deficiency and excess of Oxygen.

2nd Pre-alarm. Both in deficiency and excess of Oxygen.

Main alarm. Both in deficiency and excess.

To facilitate event readings, the control unit has a front panel with 4 LEDs indicating which probe is currently being monitored in rotation, and a display showing the gas concentration measured.

Other technical features make this control unit extremely versatile and reliable; for example, by using a series of micro-switches it is possible to:

Select or disable the probe when not installed or faulty;

Select the type of gas to be detected (toxic or explosive);

Choose the relay functioning mode (pulsed or continuous);

Choose to enable or disable of the **intrinsic safety**.

The BX444-Mc has the prerequisite to be able to test "TEST" in two different ways:

1) System Test TEST. Pressing the TEST button tests the entire system, including the relays and accessories connected to it.

2) Maintenance TEST. With special arrangements (see page 8) you can enable the function of:

Exclusion of the general alarm relay for a maximum duration of 60 minutes.

The IP44 external structure was designed for installations on walls, or on electrical panels by means of special brackets. In addition to the alarm signal light, it is fitted with an internal buzzer.



Important: Assembly / maintenance of the appliance must be carried out by qualified personnel and in accordance with applicable laws and regulations. The manufacturer assumes no responsibility for the use of products that have to comply with particular environmental and / or installation standards.



Important note

Before connecting the equipment, it is recommended that you read the instruction manual carefully and keep it for future reference. It is also recommended to perform the electrical connections correctly as per enclosed drawings, observing the instructions and the Standards.

N.B. Refer to the documentation in all cases where the symbol is on the side



**Installation
and user guide**



**INSTALL IN SAFE
AREA, NO ATEX**

CONFORMITY

EN 50194

EN 45544-1-3

EN 50270

EN 61010-1



Compliant EN 60079-29-1

Installation EN 60079-29-2

Reports issued by TUV Italia

Precautions

CHECK the integrity of the probe after having removed it from the box.
Check that the data written on the box correspond to the type of gas used.
When doing the electrical connections, follow the drawing closely.

Any use of the detector for purposes other than the intended one is considered improper, and as a result of which **BEINAT S.r.l.** therefore disclaims any responsibility for possible damages caused to people, animals or objects.

IMPORTANT: The operation test should not be carried out with the gas tap as this does not guarantee a sufficient concentration to activate the general alarm.

TERMS and EXPECTATIONS: The installation of the **BX444-Mc** probe, its ordinary and extraordinary maintenance, and its out of service removal at the end of the functional life guaranteed by the manufacturer, must be carried out by **authorized and/or specialized personnel**.

Do not allow it to become wet.

The probe can be seriously damaged when immersed in water. Remember that the probe has a protection degree IP44.

Do not drop it.

Heavy knocks or falls during transportation or installation can damage the appliance.

Avoid abrupt temperature fluctuations.

Sudden temperature variations can cause condensation and the probe could work poorly.

Cleaning

Never clean the device with chemical products. If necessary, wash with a moist cloth.

Absolutely avoid using any cloth dipped in thinners, alcohol and chemical detergents.

MAINTENANCE

The user periodically (every 6 months) must perform a check of the operation of the control unit by spraying a suitable test gas at the base of the probes connected until the alarm condition is reached.

- At least once a year make a more accurate check by a specialist technician.
- Disabling the detector must be carried out by qualified personnel.



Technical Specifications

Main Power Supply boxed version	110/230VAC 50/60Hz $\pm 10\%$
Secondary Power Through Battery Max 2,2 Ah (Optional)	12 V $\pm 10\%$
Battery Charger max 2.2 Ah	Controlled
Power Demand	9,3W max @ 230V
Power Demand	5W max @ 12V
Relay Contact Range	10A 250VAC resistive - 5A 30Vdc resistive
1 st Pre Alarm	Set to 8% of L.E.L. or 120ppm CO
2 nd Pre Alarm	Set to 13% of L.E.L. or 200ppm CO
Final Alarm	Set to 20% of L.E.L. or 300ppm CO
..	
Monitored Gas Indication	Through backlit color display
Number of Conventional Sensors that can be connected	4
Micro-switches to include or exclude the probes	1 per each probe
Connectable probes	Semi-conductor, Catalytic, Electrochemical cell, Pellistore, Infrared Rays
Type of faults detected by Fault Circuit	Interruption, short circuit, or wear
Input Signal	4 \div 20 mA on 220 ohm
Device Accuracy	1% FS
Response Time	< 2"
Control Unit	microprocessor
Functioning Temperature	-10°C \div +60°C
Waiting, blinking period	90 seconds
Manual Test	Built in
Max. distance between probes and unit	100 m
Cable diameter for connecting probes	1 mm ²
Connection: The cable of connection of the probe must not be installed together with the power cables. Otherwise, make sure to use a shielded cable	
Size DIN EN 50092	144*144*110
Degree of Protection	IP44
Warranty.....	3 years

WARNING! Actions to be taken in case of alarm

Gas

- 1) Put out all free flames.
- 2) Close the main gas tap or the LPG cylinder tap.
- 3) Do not turn any lights on or off; do not turn on any electrical device or appliance.
- 4) Open windows and doors in order to increase ventilation.

If the alarm stops, its cause must be found and the relevant consequent measures taken.

If the alarm continues and the cause of gas presence cannot be found or removed, abandon the building and call the emergency services when outside (fire department, distributors, etc.)

IMPORTANT: The operation test should not be carried out with the gas tap as this does not guarantee a sufficient concentration to activate the general alarm.

Warning !!

If you have the following symptoms: vomiting, sleepiness, or else, go to the closest first aid station and inform the operators that you could have been poisoned by **Carbon Monoxide**, or **by an excess or deficiency of oxygen**



Main Compatible Probes

Probe	Sensor	Degree Protec.	Suitable for	Gas Detected	Range Working Sensor	Output	Precis.	Calibration Relay Automatic
SG500	Catalytic	IP30	Domestic Use	CH4-LPG	0÷100% LEL	4÷20 mA	±5 %	NO NO
SG544	Catalytic	IP44	Tertiary	CH4-LPG	0÷100% LEL	4÷20 mA	±5 %	NO NO
SGM595	Catalytic	IP55	Tertiary	See catalogue	0÷100% LEL	4÷20 mA	±5 %	Yes NO
SGM595/A	Catalytic	IP66	Zone 2	See catalogue	0÷100% LEL	4÷20 mA	±5 %	Yes NO
SGM533	Catalytic	IP55	Tertiary	See catalogue	0÷100% LEL	4÷20 mA	±5 %	Yes Yes
SG800	Catalytic	IP66	Zone 2	See catalogue	0÷100% LEL	4÷20 mA	±5 %	Yes Yes
HCF100	SemiCondut	IP55	Tertiary	FREON	0÷300% ppm	4÷20 mA	±5 %	NO Yes
SG895	Pellistor	ATEX	Zone 1	See catalogue	0÷100% LEL	4÷20 mA	±5 %	Yes NO
SG580	Catalytic	IP66	Zone 2	See catalogue	0÷100% LEL	4÷20 mA	±5 %	Yes NO
SGF100	Catalytic	IP64	Zone 2	Methane	0÷100% LEL	4÷20 mA	±5 %	Yes Yes
SGF102	Catalytic	IP64	Zone 2	LPG	0÷100% LEL	4÷20 mA	±5 %	Yes Yes
SGF104	Optical Fluores	IP64	Zone 2	Oxygen	In %	4÷20 mA	±5 %	Yes Yes
SGF106	SemiCondut	IP64	Zone 2	FREON	0÷300% ppm	4÷20 mA	±5 %	Yes Yes
SGF108	Elettrochimica	IP64	Zone 2	H2S	0÷300% ppm	4÷20 mA	±5 %	Yes Yes
SGF110	Electrochemical	IP64	Zone 2	CO	0÷300% ppm	4÷20 mA	±5 %	Yes Yes
SGF112	Catalytic	IP64	Zone 2	Hydrogen	0÷100% LEL	4÷20 mA	±5 %	Yes Yes
CO100r	Electrochemical	IP55	Tertiary	CO	0÷300% ppm	4÷20 mA	±5 %	Yes Yes
CO100Ar	Electrochemical	IP66	Zone 2	CO	0÷300% ppm	4÷20 mA	±5 %	Yes Yes
SG800 ^{duct}	Catalytic	IP66	Zone 2	CH4LPG	0÷100% LEL	4÷20 mA	±5 %	Yes Yes
CO200 ^{duct}	Electrochemical	IP66	Zone 2	CO	0÷300% ppm	4÷20 mA	±5 %	Yes Yes

Application in:

Domestic: family accommodation. Local boilers up to 70 kW-h

Tertiary Areas: Large Rooms Boilers, Workshops, Material Deposits, Industrial Kitchens, Large Buildings, Buildings.

Zone 2 - Mixed IP66 ATEX: High probability of escape, high risk locations, premises for which applicable regulations apply.

Zone 1 - Hazardous Area, High Risk Hazards, Rooms for Which Regulations, Tanks, Control Valves are in force.

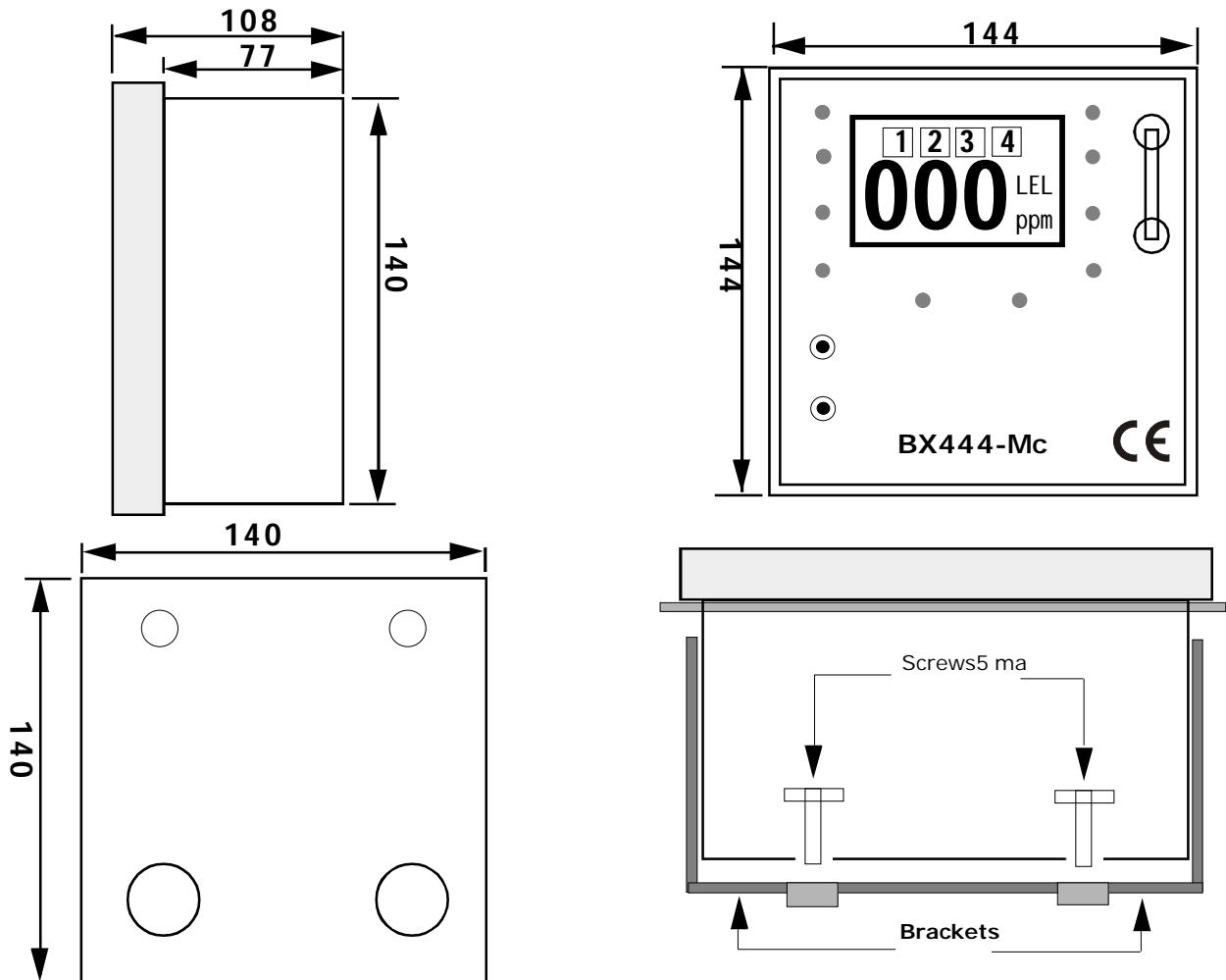

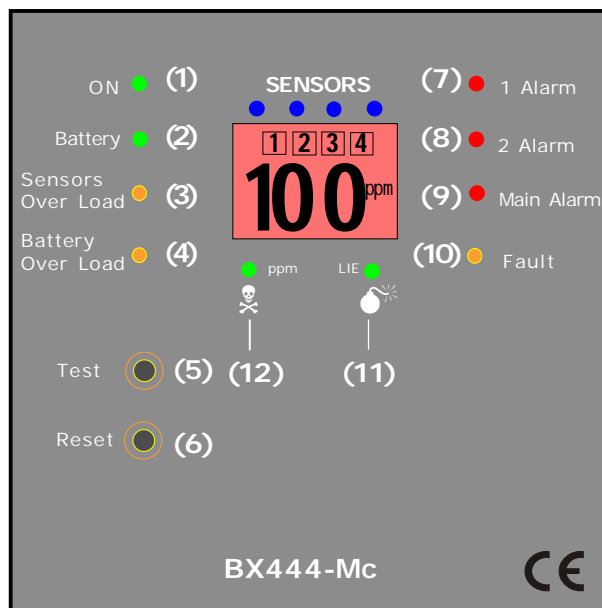
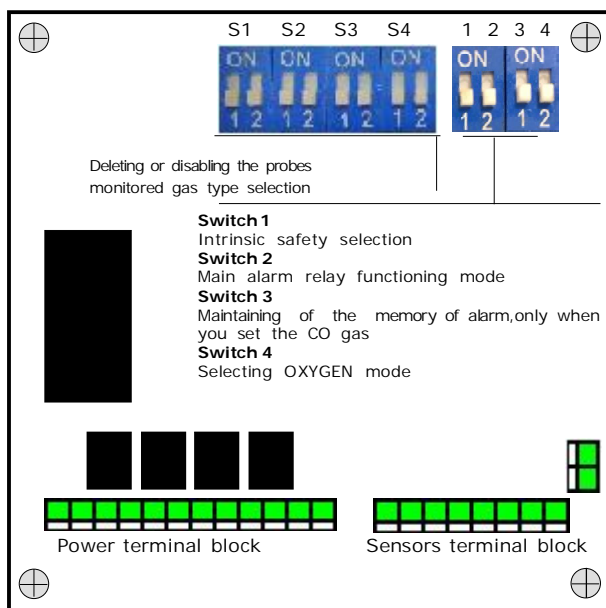

- 1) LED **ON**. It blinks for about 2 minutes (warm up time) when the mains power is supplied. When ready, the LED stays on without blinking.
- 2) **BATTERY** LED. It lights up (fixed) when no mains power is present and the control unit is supplied by a 12Vdc battery. It blinks when the battery is flat.
Note: During the warm up time the control unit is not capable of detecting gas.
- 3) **OVER LOAD PROBES** LED. If this LED turns on, it means there is a short circuit or high current absorption in the probes.
- 4) **OVER LOAD BATTERY** LED. If this Led turns on, it means the battery is not connected properly, or it has an anomalous voltage absorption.
- 5) **TEST** BUTTON. Pressing and holding down this button, you can obtain a gas leakage simulation. In order to perform this operation no failures or alarms should be present.
- 6) **RESET** BUTTON. This button is pressed to clear all memories, or to restore the control unit after a failure.
- 7) **1st Alarm** LED. This LED will light up when the gas concentration level has reached 8% of LEL, or 120ppm (ref. CO), and the 1st threshold relay contact is closed. The relay disenergizes when the 13% of LEL, or 200ppm CO, threshold is exceeded.
- 8) **2nd Alarm** LED. This LED will light up when the gas concentration level has reached 13% of LEL, or 200ppm (ref. CO), and the 2nd threshold relay contact is closed. The buzzer will issue a low frequency sound. The relay disenergizes when dropping below the 13% of LEL, or 200ppm CO, threshold.
- 9) **MAIN ALARM** LED. This LED will light up when the gas concentration level has reached 20% of LEL, or 300ppm (ref. CO), and the MAIN ALARM relay contact is closed. The buzzer will issue a high frequency sound.
- 10) **FAULT** LED. This LED blinks when one of the connected probes is faulty, if there is an interruption in the cable connection, or if an error was made during wiring. When this LED is blinking, the device is no longer capable of detecting. To reactivate the device, the damaged probe must be repaired or disabled using the internal micro-switch (see chapter 6 paragraph A) and then the RESET button must be pressed.
- 11) **EXPLOSIVE GAS** LED. If this LED is turned on, the probe is set to detect explosive gas (Methane, LPG, etc.).
- 12) **DISPLAY backlight colours**. The symbols are illustrated in the draw.
 - a) The symbol of the battery light on when the **BX444-Mc** is powered with an external battery. The drawn battery indicates the state of load of the battery and when it blinks it means that the battery is low.
 - b) The number on the display indicates the concentration of gas detected. The exchange of data of every connected probe is every about 4 seconds.
 - c) The letters **ppm** means when the connected probe detects **Toxic gas**. The letters **LEL** means when the connected probe detects **Explosive gas**.
 - d) The symbol of the time means when the **BX444-Mc** is being the Warm up and displays the countdown.
- 13) **TOXIC GAS** LED. If this LED is turned on, the probe is set to detect toxic gas (Carbon Monoxide).
- 14) **SENSORS** LEDs (of the probes). These LEDs represent the connected probes and will light up in sequence.

11) **DISPLAY.** The symbols are illustrated in the draw.

a) The number on the display indicates the concentration of gas detected.

The exchange of data of every connected probe is every about 4 seconds.

b) Numbers from 1 to 4 indicate the monitored probe.

c) The letters **ppm** means when the connected probe detects **Toxic gas**.

The letters **LEL** means when the connected probe detects **Explosive gas**.

d) **The timer symbol** means when the **BX444-Mc** is being the Warm up and displays the countdown.

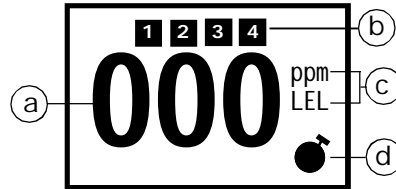

Description of Display

The **BX444Mc** is equipped with a display backlight color to facilitate the recognition of the state of the probe monitored.

The data exchange for each probe connected happens every 4 seconds.

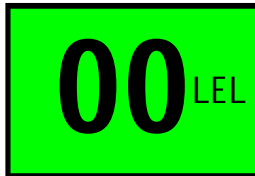

The green display shows an absence of leakage of gas, normal conditione

The display shows with red color a concentration of explosive gases in % LEL greater than a threshold alarm.



The blu display shows the percentage of oxygen. normal condition

The display shows with red color a concentration of toxic gases ppm greater than a threshold alarm.



The yellow display shows a fault of one or more probes.



The **BX444-Mc** presents three levels of danger which are:

1st Pre-Alarm	<	19.9 %
	>	21.9 %
2nd Pre-Alarm	<	19.5 %
	>	22.5 %
Main alarm	<	18.5 %
	>	23.5 %

< **Oxygen deficienty**
> **Excess Oxygen**

The installation of the detector is not exempt from The compliance with all regulations concerning the characteristics, installation and use of gas appliances. The ventilation of the spaces and the elimination of combustion products are described in the UNI norms according to ART. 3 LAW 1083 / 71 and relevant legal provisions.

Electrical Connections



WARNING.

Before connecting to the mains power, ensure the voltage is correct. Carefully follow the instructions and the connections according to Regulations in force, keeping in mind that **the signal cables should be laid separate from the power cables.** An automatic cut-off switch (appropriately identified as devicesectioning of the detector) should be incorporated in the electrical system, adequatelylocated and easily accessible.

Legend setting switches

- S1) switch group reserved to the probe N° 1
- S2) switch group reserved to the probe N° 2
- S3) switch group reserved to the probe N° 3
- S4) switch group reserved to the probe N° 4

- 1) Selection of positive safety
- 2) Operating mode of the main alarm relay.
- 3) Selection of MEMORY. **N.B.** You can remove the selection of memory when the gas CO is selected.
- 4) Selecting OXYGEN mode

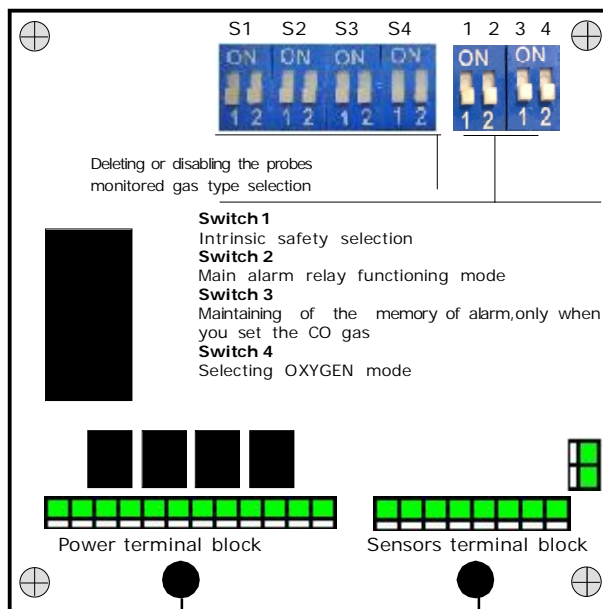
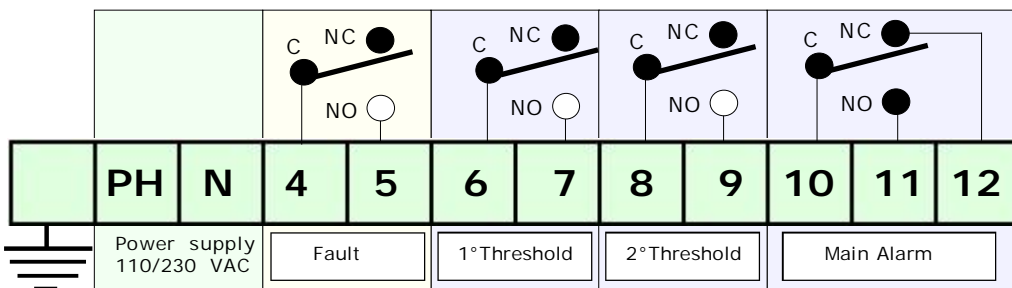

Diagram of the terminal block relay

PLEASE NOTE!

All relays are free of voltage



Probes connection and eventual battery

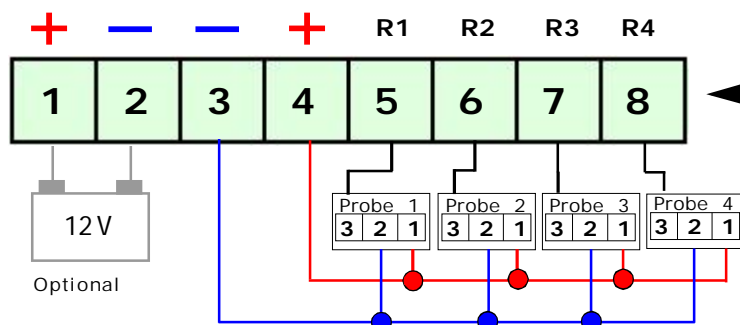

Connection examples

Connections of a solenoid valve Normally Closed without Positive Safety

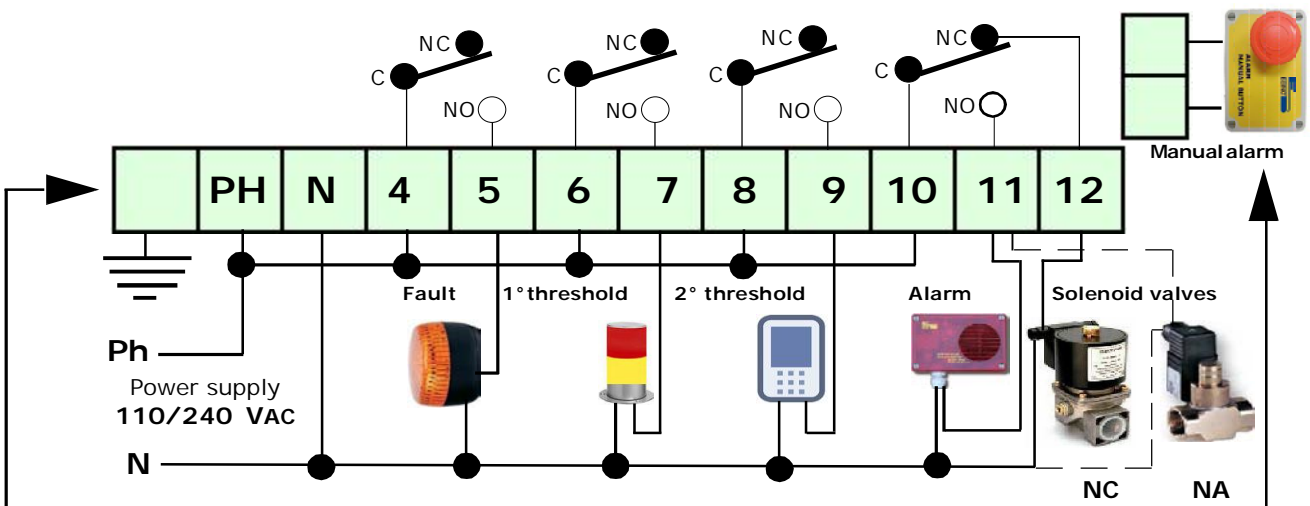

Connections of a solenoid valve Normally Closed with Positive Safety

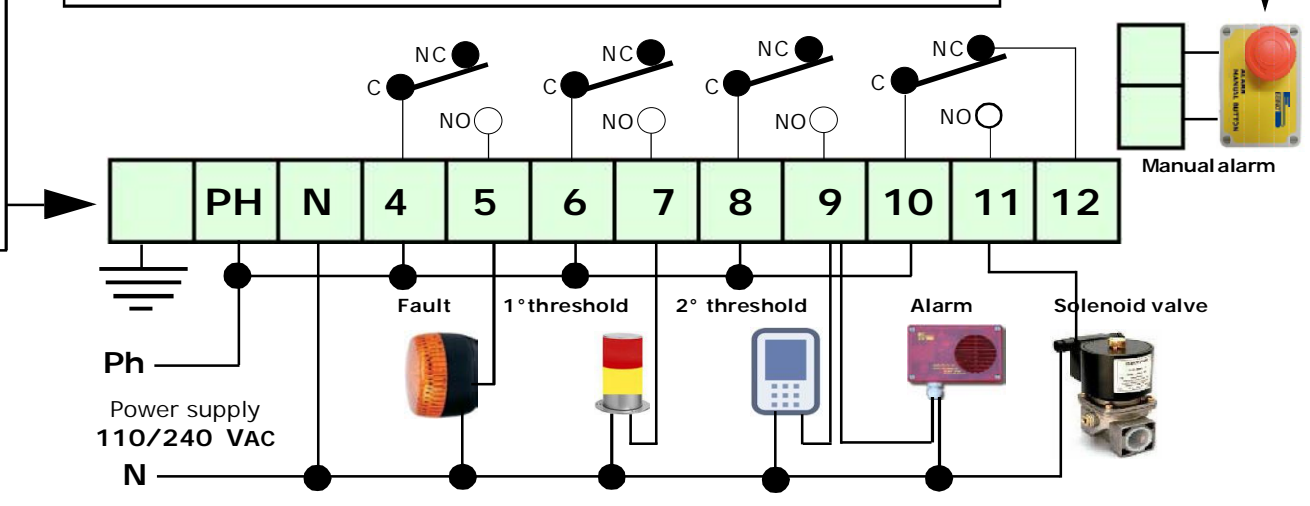

If a 12Vdc solenoid valve, which does not work well, is connected to the BX444-Mc. Direct connection of 12VDC solenoid valves or sirens to the BX444-Mc is not permitted. An external power unit must always be used. The BX444-Mc gives a max current of 100mA. **Control unit power supply and connection of one solenoid valve with sirens to 12 VDC trough an alternative source and recharge battery.**

Solenoid valve GAS and Sirens 12 VDC

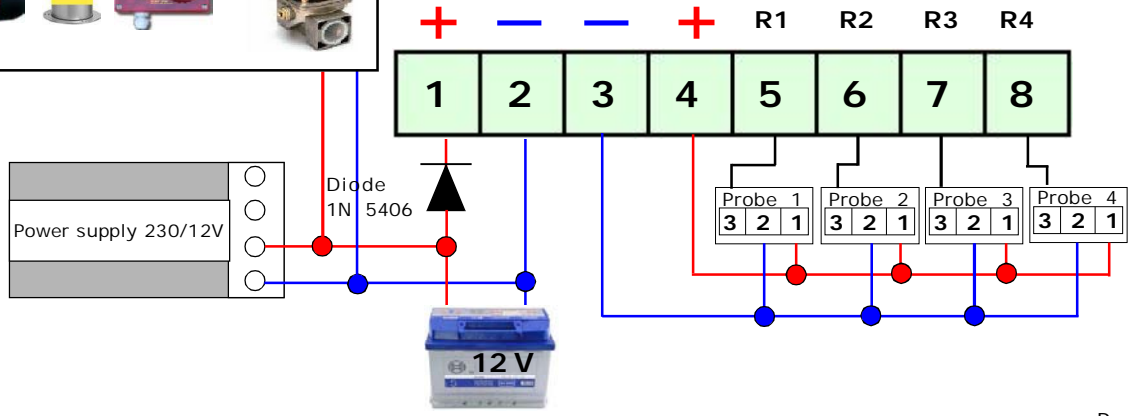

Components and Commands continue

Probe Identification Leds from n°1 to n°4

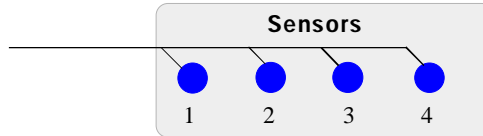

A row of LEDs numbered from **1 to 4** and called PROBES has been fitted on the **BX444-Mc**. These LEDs are lit with a 2 second frequency representing the connected probes, and indicate the probe being read on the display.

In case of alarm: The LED that represents the probe stops for about 15 seconds. This is done in order to identify the relevant zone or zones easily. The gas percentage measured by the probe appears on the display and is maintained for 15 seconds. On the next pass, the LED (probe) will be maintained again and the alarm will be issued.

In case of fault: The LED of the relevant probe starts blinking and remains lit. The display will show the **"FAU"** (Fault) fixed indication, and the buzzer will issue a continuous sound until:

- 1) The repair has been carried out;
- 2) The relevant probe has been disabled using the micro-switch.

Maintenance Test

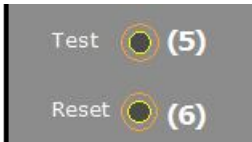

The simultaneous and prolonged pressure for 5 sec of the "TEST" and "RESET" buttons enables the test-on mode in which the control unit does not switch the general alarm relay for a period of 15 minutes; Not even pressing the external manual button.

A further keypress in the same mode extends the time of 15 minutes to a maximum of 60 minutes.

In this mode, before the passage from the current channel to the next, the "TEST-ON" string is displayed followed by the minutes of the general alarm relay being switched off.

You can terminate this mode before the natural deadline by resetting the control unit by pressing 3 consecutive times and within 5 seconds the RESET button.

Description of Micro-switches

Installing, uninstalling or disabling probe

Through the Micro switches (see drawing below) on the control unit, you can to activate or to deactivate **4 Zones**.

You can connect 4 probes to the **BX444-Mc**. The control unit is tested with the probes connected

In some installations, you may need only one probe. In this case we will proceed to disable a probe, to do this select the switch of the probe (zone) concerned.

These micro-switches are also used to disable one or all probes in case of failure

N.B. The microswitches are also used for switching off in case of failure

Micro-switch (1) to enable or to disable the probe.
Position **ON** enabled - In position **OFF** disabled

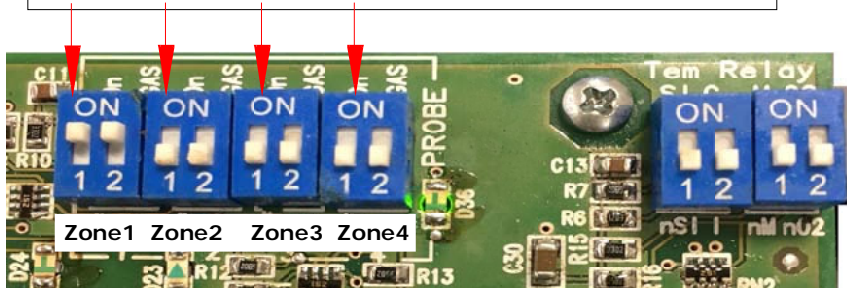

Components and Commands continue

Selection of the type of gas monitored by each probe

The **BX444-Mc** is fitted with four micro-switches in order to select the type of gas that the connected probes should monitor.

The LEL reading is obtained by shifting the switch to **ON**. **Explosive gas**.
The ppm reading is obtained by shifting the switch to **OFF**. **Toxic gas**

Micro-switch **(2)** to select the type of gas monitored
Position **ON** reading in LEL - **Explosive gas**
Position **OFF** reading in ppm - **Toxic gas**

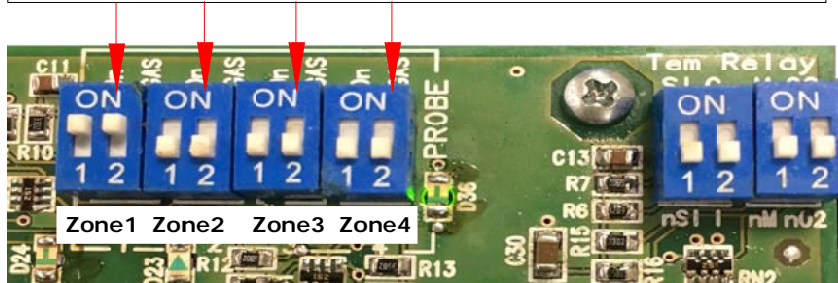

● ppm LEL ●

Light signaling the type of gas selected

ppm is the reading of the concentration for the **CO gas**

LEL is reading of the concentration for **Explosive Gas** (Methane or LPG)

Relay's working mode and the memory of the Main alarm

Micro-switch **1** Positive Safety
Micro-switch **2** working mode of the Main Alarm relay
Micro-switch **3** Maintaining Memory
Micro-switch **4** Enabling Oxygen mode

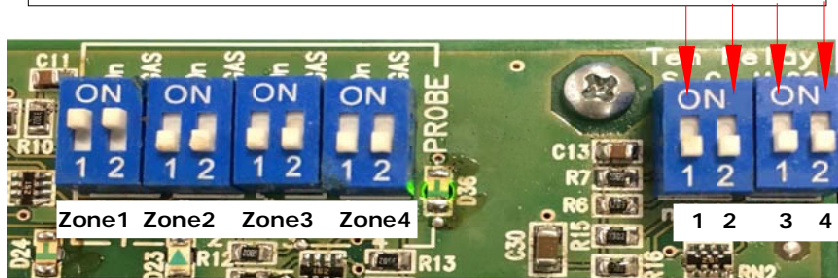

Switch 1 – Selection of the intrinsic safety

In the **ON** position, the intrinsic safety function is enabled.
In the **OFF** position, the intrinsic safety function is disabled

Switch 2 - Working Mode of Main alarm relay

In the **OFF** (impulse) position, the relay remains closed for seconds, and then disenergizes afterwards.
In the **ON** (continuous) position, the relay remains closed until the **RESET** button is pressed.

Switch 1 (3) - Alarm memory logging

By setting the micro-switch to **ON**, the device **will log** the alarm, maintain the relay closed, and the main alarm LED will blink, until the RESET button is pressed.

By setting the micro-switch to **OFF**, the device **will not maintain** the alarm memory and the relay switches off when the connected probe no longer detects gas; **In compliance with the rules this function becomes active only when you select the detection of Toxic Gases** (reading in "ppm")

Switch 2 (4) - Selecting of the control unit in oxygen detection mode

By setting the micro-switch to **ON**, the device **is ready to detect the oxygen**. The display changes color and becomes BLU

ATTENTION !! Selecting the detection of oxygen the control unit will be enabled to detect **OXYGEN**, and not other types of Gas

By setting the micro-switch to **OFF**, The control unit is ready to explosive or toxic gas detection.
The display changes color and becomes green.

Installation and positioning of the Sensors

The **BX444-Mc** control unit belongs to group II and must be installed in a safe area: **Outside the ATEX zone**, however, not in boiler rooms or engine room. The control unit must be accessible and visible to the user.

The **BX444-Mc** is designed so that it can be mounted externally or built into electrical panels. The **Control Unit** complete cabinet is an equipment suitable for wall mounting and is powered by **110/240 VAC** with **IP44** protection

When installing, it is good to use the normal care that an electronic equipment requires:

- Install the equipment away from excessive heat sources.
- Avoid liquids coming into contact with the control unit, remembering that its external structure has IP20 degree of protection **if installed on the Boxed version (cabinet) supplied to the source is IP44.**

The sensors must be selected with an IP degree depending on the area to be controlled (Kitchens, Boiler Rooms, Laboratory, etc.) by selecting one of the probes from Beinat from IP30 to ATEX. see page 3

Position of the detection sensors

You can connect many types of remote sensors to this unit. Therefore, they should be positioned at different heights depending on the type of gas to be detected.

These heights are:

- **30 cm** from the lowest point of the floor in order to detect: *Heavy gases (L.P.G. etc.)*
- **30 cm** from the highest point of the ceiling in order to detect: *light gases (Methane, etc.)*
- **160 cm** from the lowest point of the floor in order to detect: *volatile gases (CO, etc.)*

It is important to note that the remote probes should be installed according to the following restrictions:

- 1) The sensors should not be placed near the appliances to be controlled (boilers, burners, industrial kitchens, etc.) but on the opposite side.
- 2) The sensors should not be affected by smoke, vapour, and moving air, as they could distort their measurement.
- 3) The sensors should not be placed near sources of heat, ventilators or fans.

It should be noted that the internal GAS sensors of the probe are perishable components with a variable average life span from 5 to 6 years (you can request the relative table). Therefore, after this period of time has elapsed it is advisable to replace them.

- 4) The control of operation and maintenance and / or extraordinary **must be carried** at least once a year. good to keep

When turning on leds fault is necessary make the replacement of the probe by a specialized technician.

PROBE INSTALLATION INFORMATION

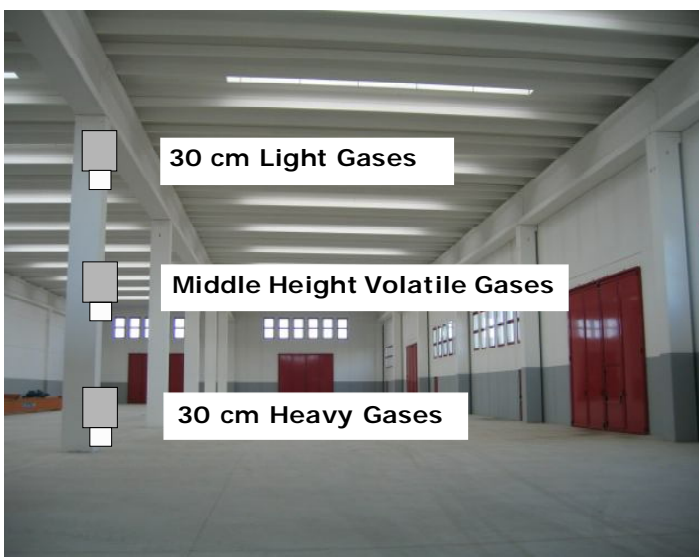

When all else fails, read instructions

Turning on the BX444Mc

- 1) Apply power using the proper switch. This switch should be fitted with protection fuses.
- 2) You will notice that some LEDs will light up in turn for about 20 seconds, so as to test the LEDs.
- 3) The COUNTDOWN begins that lasts about 90 seconds (warm up) after this the unit is ready to detect.
- 4) By pressing the MANUAL TEST button, you get the simulation of a gas leak and the unit carries out the following:
 - a) **The Pre-alarm** LED lights up calibrated to 13% LEL or 200 ppm (referred to CO) switching the relay the buzzer will issue a low frequency sound
 - b) **The Main alarm** LED lights up calibrated to 20% LEL or 300 ppm (referred to CO) switching the relay. The Main alarm LED starts flashing; the buzzer will issue a high frequency sound
- 5) To complete the general test, issue gas from a pre-calibrated aerosol
- 6) If you want to simulate a zone fault, you only need to disconnect the return cable of the corresponding probe.
When the fault LED turns on a continuous sound will warn you of the failure. At the same time, the relevant relay will switch to its position.

Troubleshooting and solutions before calling a technician



-If the device does not start up.

Check that the 240VAC mains power is correctly connected. If powered by the battery, check that the 12Vdc power is correctly connected.

-If the Fault LED lights up.

Check that the connecting cables from the BX444-Mc to the probes are intact that the probes are properly powered and that the signal cable is correctly connected.

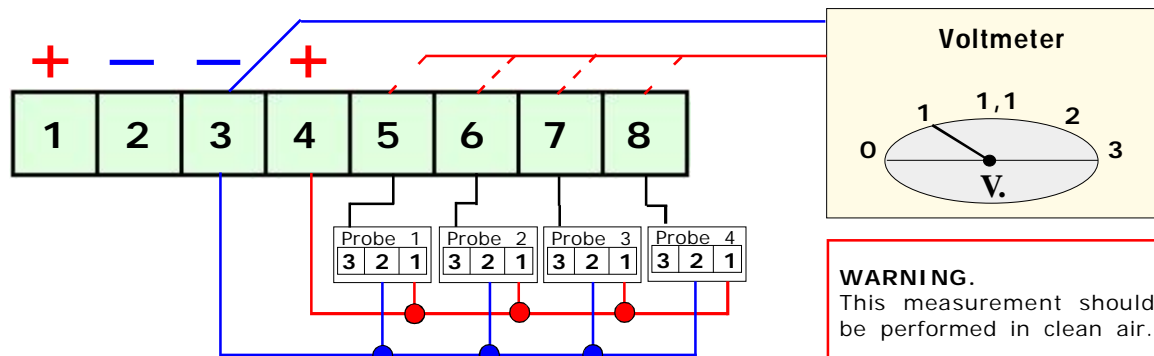

-If the Over Load Probe LED lights up.

Check: that the power polarity has not been inverted, that no short-circuit is present, that the probes were not damaged during installation, that no excessive current absorption is present.

-If the Over Load Battery LED lights up.

Check that the connection cables are not short-circuited, that the polarity has not been inverted, or that the battery is not damaged

-If the Control Unit is repeatedly issuing an alarm.

Check that there are no gas leaks. If the alarm signal and the FAULT indicator light turn on together, check the probes.

-If the Control Unit is issuing an alarm and does not shut off the devices connected to it.

Check that the wiring is correct and that the jumper that carries power to the relay has been set properly.

-All relays must be free from electrical power.

Check the drawing of the connections.

If a 12Vdc solenoid valve, which does not work well, is connected to the BX444-Mc.

Direct connection of 12VDC solenoid valves or sirens to the **BX444-Mc** is not permitted.

An external power unit must always be used.

The BX444-M gives a **max** current of **100mA**.

If other problems arise, a specialised and/or authorised technician and/or the Distributor of **BEINAT S.r.l.** should be contacted directly.

INSURANCE. This device is insured by the SOCIETÀ REALE MUTUA for the PRODUCT'S GENERAL LIABILITY up to a maximum of 1,500,000.00 EURO against damages caused by the device in case of failures in functioning.

WARRANTY. The warranty term is 3 years from manufacturing date, in agreement with the following conditions. The components acknowledged as faulty will be replaced free of charge, excluding the replacement of plastic or aluminium cases, bags, packing, batteries and technical reports.

The device must arrive free of shipment charges to **BEINAT S.r.l.**

Defects caused by unauthorized personnel tampering, incorrect installation and negligence resulting from phenomena outside normal functioning shall be excluded from the warranty.

BEINAT S.r.l. is not liable for possible damage, direct or indirect, to people, animals, or things; from product faults and from its enforced suspension of use.



DISPOSAL OF OLD ELECTRICAL & ELECTRONIC EQUIPMENT.

This symbol on the product or its packaging indicates that this product shall not be treated as household waste. Instead, it shall be handed over to the applicable collection point for the recycling of electrical and electronic equipment, such as for example:

- sales points, in case you buy a new and similar product
- local collection points (waste collection center, local recycling center, etc...)

By ensuring this product is disposed of correctly, you will help prevent potential negative consequence for the environment and human health, which could otherwise be caused by inappropriate waste handling of this product. The recycling of materials will help to conserve natural resources. For more detailed information about recycling of this product, please contact your local city office, your household waste disposal service or the shop where you purchased the product.

Attention: in some countries of the European Union, the product is not included in the field of application of the National Law that applies the European Directive 2002/96/EC and therefore these countries have no obligation to carry out a separate collection at the "end of life" of the product.



Control Unit BX444-Mc *Lo styling è della b & b design*

Dealer stamp

Purchase date:

Serial number:

Beinat S.r.l. following the purpose of improving its products, reserves the right to change the technical, aesthetic and functional characteristics at any time and without giving any notice.

BEINAT S.r.l.
 Via Fatebenefratelli 122/C 10077, S. Maurizio C/se (TO) - ITALY
 Tel. 011.921.04.84 - Fax 011.921.14.77
 http:// www.beinat.com

Business - info@beinat.com
Technical support - laboratorio@beinat.com